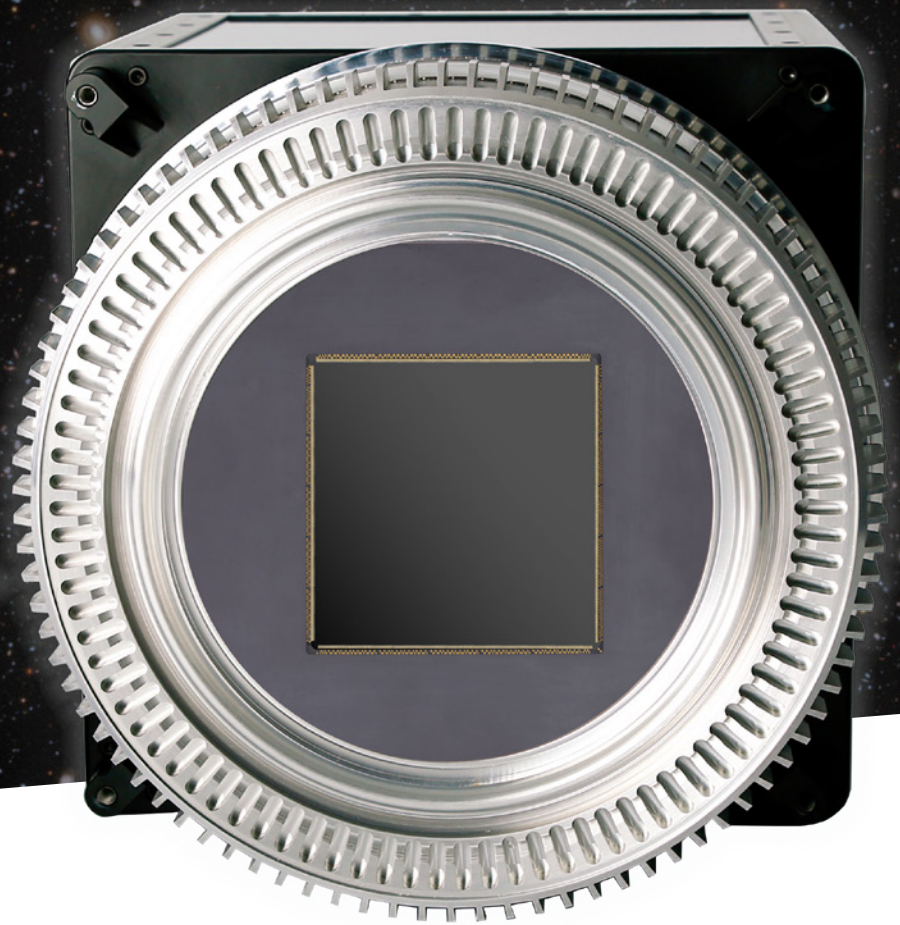

**COSMOS™****LARGE
AREA
CMOS
CAMERAS**

The Next Generation of
High-Performance, Large-Array
Cameras for Astronomy

Contents

COSMOS – Merging CCD and CMOS performance.....	3
Teledyne Imaging Heritage.....	3
LACera Technology.....	4
COSMOS Specifications.....	5
Key Features.....	7
Measuring Sensitivity.....	7
Multiple Readout Modes.....	7
Dynamic Range.....	8
Shot Noise Limited HDR.....	9
HDR Readout Mode.....	9
Shutter Modes.....	10
Frame Rates.....	11
Deep Cooling and Lifetime Vacuum.....	11
Hardware Interface.....	12
Software Interface.....	12

Introducing COSMOS™

Merging CCD and CMOS performance



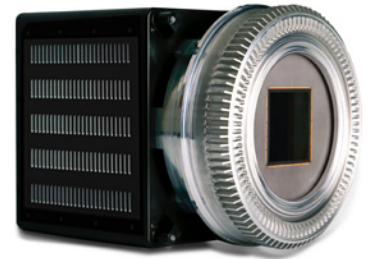











COSMOS™ will meet the increasing demand for higher performing sensor technology by combining the essential elements of both CCD and CMOS technology to create a new generation of devices that are distinctly different from anything currently available on the market. COSMOS is the optimal combination of resolution, pixel size, sensitivity, and speed. It is the only large format, high performance CMOS camera designed and manufactured entirely within a single source.



- 0.7 e- read noise for detection of faint objects
- Up to 8k x 8k sensor sizes for maximum field of view
- >90% peak quantum efficiency for high sensitivity
- High duty cycle and up to 50 fps for capturing dynamic events
- Large dynamic range to prevent sensor saturation
- Rolling and global shutter

Teledyne Imaging Heritage

Built upon decades of detector design and fabrication, Teledyne Imaging has provided solutions for a wide range of world changing projects, such as the Mars Rover missions, been implemented on multiple observatory instruments, such as the European Southern Observatory Very Large Telescope MICADO, HARMONI, METIS, and MUSE, and involved in multiple surveys, such as the Javalambre Physics of the Accelerating Universe Astrophysical Survey. Teledyne Imaging’s sensors, cameras, and imaging systems can address virtually any imaging requirement for airborne, space, defence, or security applications...

Ground Astronomy	Earth Observation	Space Science	Planetary Exploration	Space Astronomy
 <p>30+ Telescopes</p>	 <p>80 Flown Missions</p>	 <p>50 Flown Missions</p>	 <p>12 Flown Missions</p>	 <p>10 Flown Missions</p>
 <p>10 Under Construction</p>	 <p>20 Planned Missions</p>	 <p>10 Planned Missions</p>	 <p>2 Planned Missions</p>	 <p>2 Planned Missions</p>
 <p>500+ Sensors Delivered</p>	 <p>2000+ Years in Orbit</p>	 <p>600+ Years in Space</p>	 <p>300+ Years Space Exploration</p>	 <p>2200+ Years in Space</p>



LACera Technology

Large Area CMOS

ONLY FROM TELEDYNE IMAGING

LACera™ represents the dawning of a new era in CMOS technology, exclusively developed and owned by Teledyne Imaging. LACera is a monumental step forward in CMOS capabilities for advanced imaging, enabling the next generation of discovery. The challenge of CMOS sensors has been maintaining performance when scaling to larger formats.

LACera combines high speed and low noise architecture, while delivering deep-cooled, low-noise performance on a multi-megapixel scale with global shutter, 18-bit readout, and glow reduction technology.

LACera represents a critical element of advanced imaging solutions and is only possible with the nature and scale of Teledyne. From pixel, sensor, and ROIC design, through low noise electronics, to deep cooling, and system interface, Teledyne is the only company capable of delivering this one hundred percent organic solution in large-format CMOS.



COSMOS: Harnessing LACera Technology

Utilizing the powerful technology of LACera, COSMOS also combines low-noise electronics and novel sensor cooling and packaging to deliver unprecedented performance. Typical CMOS limitations, such as "glow", limited dynamic range, and compromised global shutter, have also been improved to provide a turnkey product that answers the demands of many applications.

COSMOS-10



3260 x 3260
10 micron

COSMOS-42

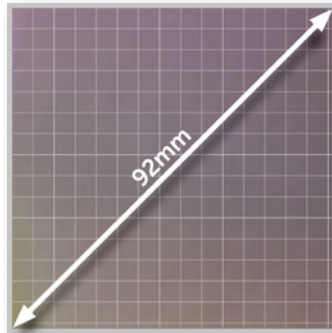

6500 x 6500
10 micron

COSMOS-66

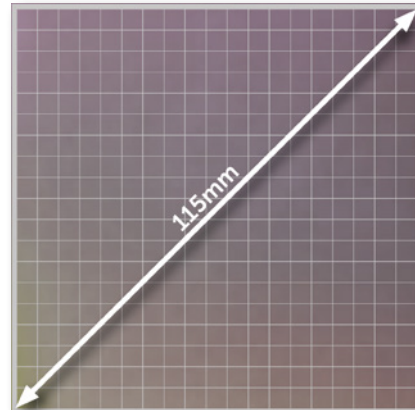

8120 x 8120
10 micron

Specifications

Camera Specifications

Feature	COSMOS-10	COSMOS-42	COSMOS-66
CMOS image sensor	Back illuminated; grade 1; 100% fill factor		
Dark current @ -25°C (with ambient air @ +20°C)	0.05 e-/p/s (typical)		
Quantum efficiency	> 90% Peak QE, See QE curves on page 4		
Pixel format	10 μ m		
Imaging area	33 x 33 mm	65 x 65 mm	81 x 81 mm
Resolution	3260 x 3260	6500 x 6500	8120 x 8120
Sensor Cooling temperature	<-25°C (typical) with liquid chiller; <-20°C (typical) with air		
Cooling method	Thermoelectric air or liquid cooling (liquid chiller required)		
Full well	Single pixel: >80 ke- (typical)		
ADC settings	14, 16, and 18 bit		
System read noise	< 1.8 e-rms ¹ , <1 e- rms ²		
Frame rate (fps) ³	61	31	25
Shutter	rolling and global		
Nonlinearity	<1%		
Binning ⁴	2 x 2; 4 x 4		
Data interface	USB 3.1 Gen 2	CoaXPress®	CoaXPress®
I/O signals	Three MCX connectors: (2) Software configurable outputs, (1) trigger input		
Operating environment	-30°C to +30°C non-condensing		
ROI	Multiple regions of interest		
Certification	CE		
Power supply	110/220 V		

Specifications are preliminary and subject to change. Certification CE

1. Rolling shutter and high gain. Global shutter and high gain < 3 e- rms
2. With Correlated Multiple sampling and high gain
3. Frame rates stated with rolling shutter, non-HDR, and 14 bit digitization
4. FPGA binning

Mechanical and Electrical Specifications

	COSMOS-10	COSMOS-42	COSMOS-66
Physical Size (H x W x L)	tbc	tbc	26.2 x 26.2 x 32.8 cm (W x H x L)
Weight	tbc	tbc	18 kg
Mounting	Multiple Mechanical Options Available		
Cooling	Heat Exchanger Liquid		
Min sensor temperature	-25 °C		
Thermostating precision	+/-1.0 °C		
Ports/Cabling	USB 3.1 Gen 2		CXP12 4-Lane
Camera I/O	OUT-A, OUT-B, Trigger, Sync External Shutter Control - TTL logic Power		
Window	Fused SiO ₂ (Grade 0A), NO AR		
Cover Set	Black anodized Al		
External Lights	(1) LED indicator		
Power supply	110/220 V		
Operation environment	Temperature: -30°C ~30°C Relative humidity: ≤ 90% Altitude: 0~3900 meter		
Storing environment	Temperature: -30°C ~ 50°C Relative humidity: ≤ 90% Altitude: 0~3900 meter		

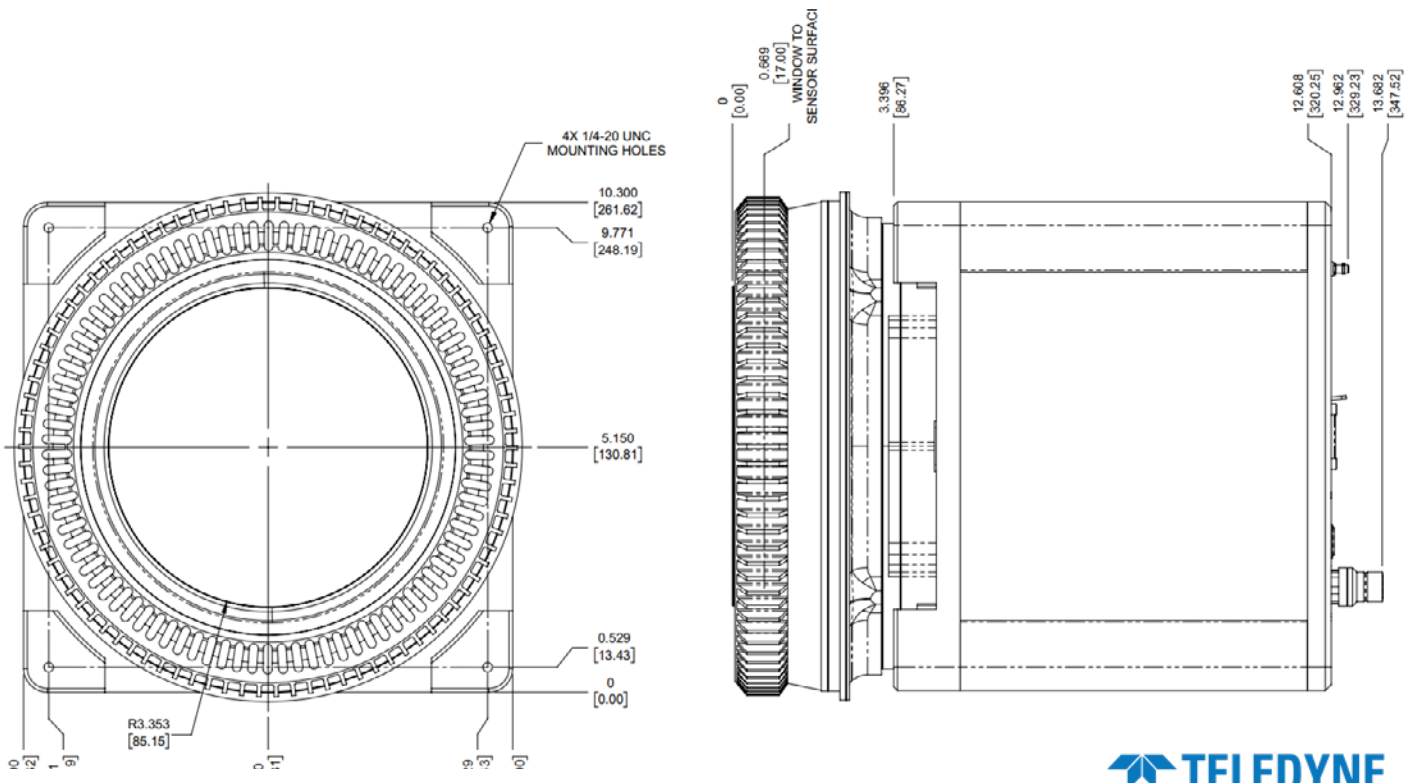

Key Features Explored

Unbeatable Sensitivity

COSMOS achieves near-perfect light collection thanks to back-illumination, with quantum efficiency peaking at over 90%. What’s more, with minimal 0.7e⁻ read noise and 0.05e⁻/p/s dark current, the COSMOS surpasses both CCD and EMCCD technology in its ability to detect weak signals.

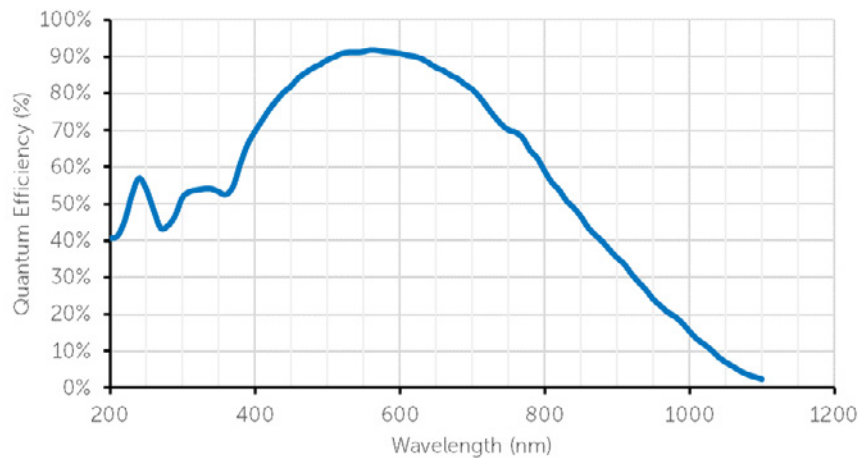

Multiple Readout Modes

COSMOS has a variety of read out modes, utilizing both global and rolling shutter modes, for the ultimate flexible configuration.

Data	Gain	Shutter Mode	8K FPS	6K FPS	3K FPS	Read Noise (e-rms)
14-bit	STD	Global	19	24	48	2.7
14-bit	STD	Rolling	25	31	61	2.7
16-bit	STD	Global	5	6	12	2.7
16-bit	STD	Rolling	6	8	15	1
18-bit ¹	HDR	Rolling	0.3	0.4	0.7	0.7

1. Assumes x8 correlated multisampling
2. Standard modes (STD) are selectable high gain/low gain
3. High gain ~12k e⁻ / Low gain ~ 80k e⁻
4. Global shutter is true global reset and transfer
5. Readout modes shown are possible modes and not all will be supported simultaneously

Dynamic Range

What is dynamic range?

Dynamic range is a measure of the total number of discernible signal levels, determined by the peak signal and the noise floor in the signal digitization process. In a CMOS sensor, we seek to find the ratio of the total number of photoelectrons a pixel can store prior to saturation and loss of linearity divided by the read noise. For example, a CMOS pixel with a 10,000 e⁻ full well (high gain) having a read noise of 3 e⁻ rms (high gain) has a dynamic range of 3333 or approximately 70 dB.

What isn't dynamic range?

Dynamic range is not equivalent to the total number of digitization levels or analog to digital units (ADUs) – i.e., a camera with a 12-bit A/D converter does not necessarily have 12 bits of dynamic range because this does not take into account the noise floor. First, the intrinsic dynamic range of the pixel must be determined, and then enforce that the A/D converters have at least that in bit resolution, preferably higher.

Dynamic range is also not equal to the sum over all bit depths of the A/D converters in a multi-conversion gain camera operating in high dynamic range (HDR) mode. For example, a camera with two or even three 12-bit sampled images does not have 24- or 36-bits dynamic range.

Dynamic range and COSMOS

The combined HDR signal in COSMOS is the merged result of two 16-bit measurements onto a larger 18-bit range. By combining the low read noise, along with the intrinsically low noise of the analog to digital converters (ADC), COSMOS enables accurate measurement of weaker signals and unlocks wider dynamic range. However, the dynamic range is still bounded by the read noise floor in high gain and the FWC in low gain. As such, the COSMOS has a dynamic range of 80,000 e⁻/0.7 e⁻-rms, which is equivalent to 114,286 discrete levels or approximately 101 dB.

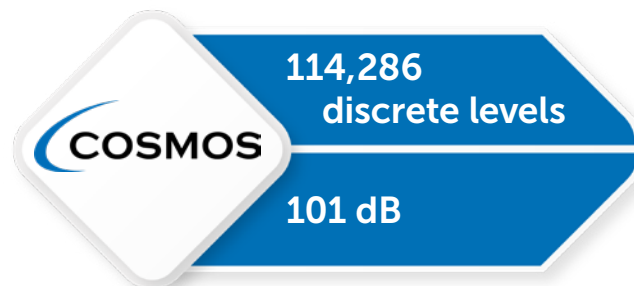

Shot Noise Limited HDR

It is common practice in sCMOS sensors to enhance dynamic range by combining 2 or even 3 conversion gains within a single CMOS pixel. This imaging modality is commonly referred to as High Dynamic Range or HDR. To understand how dynamic range is enhanced in HDR readout modes, one must first consider how read noise and full well capacity are affected by changing gain and how the final photon transfer curve (PTC) is established.

The PTC for the COSMOS sensor, in 16b high gain and 16b low gain HDR modes can be seen in the left-hand side graph. The PTC shows excellent stitching at the crossover point, with a combined HDR of 80,000 $e^-/0.7 e^-$, equating to 101 dB. This PTC curve is mapped onto an 18-bit output with a final gain of approximately 0.3 e^-/ADU .

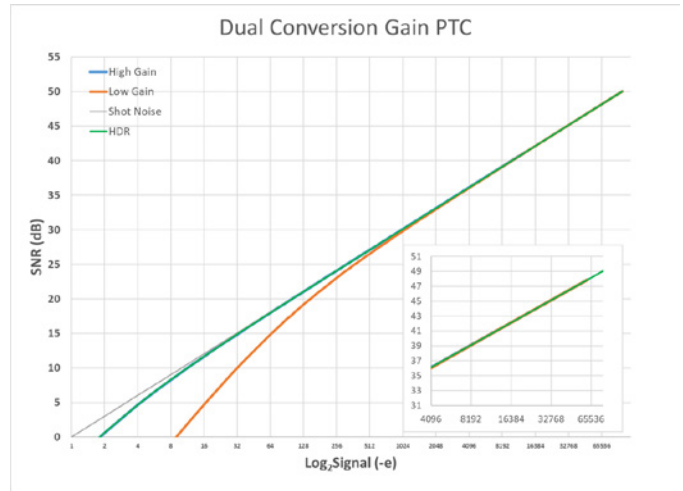

HDR Readout Mode

Our proprietary 18-bit HDR mode utilizes dual conversion gain to increase Full Well Capacity (FWC) while maintaining ultra-low noise performance. In HDR mode, each pixel is sampled twice – once with high gain and once with low gain conversion. High gain readout provides ultra-low temporal noise needed for sampling low light signals with reduced FWC. Low gain readout provides higher FWC for sampling intense signals dominated by photon shot noise where low temporal noise is less critical. Both these gain mode readouts are combined into a single image preserving the best of both worlds – ultra-low noise and high FWC providing exception dynamic range.

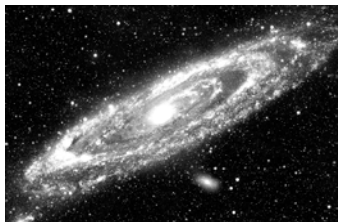

HIGH GAIN IMAGE

16 bit | 12k e^- FWC
0.7 e^- rms with CMS



LOW GAIN IMAGE

16 bit | 80k e^- FWC
<9 e^- rms



HDR IMAGE

18 bit
101dB dynamic range

Shutter Modes

CMOS sensor technology takes advantage of electronic shutters, removing the error, maintenance, and speed limitation associated with physical mechanical shutters. Although typically CMOS technology only provides rolling shutter modes, COSMOS implements both rolling and global shutter modes.

Global Shutter

This is achieved on CMOS through the addition of a 'storage area' on each pixel, where the collected signal is stored at the end of an exposure, prior to being read out. However, global shutter wasn't previously possible on back-illuminated devices, as the storage area would be exposed to light by the back-illumination processes. This meant that 'parasitic' light could be detected while pixels were awaiting readout. However, COSMOS utilizes proprietary pixel design to store converted photoelectrons, without exposing the storage area to light.

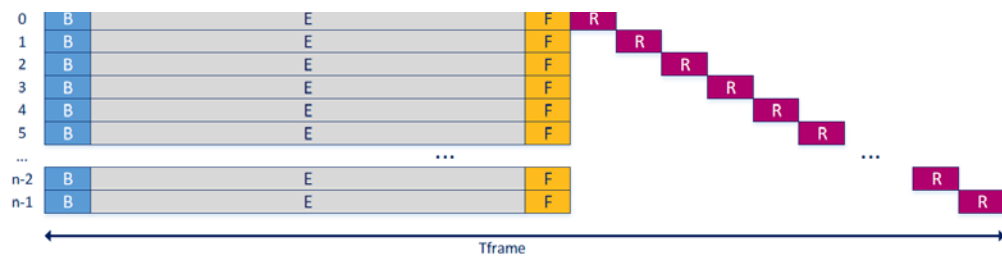

Row-by-row readout after global F states in global shutter

Rolling Shutter

This mode yields low noise due to the cancellation of the reset noise due to on-chip "true" Correlated Double Sampling. Both the image acquisition and readout are performed in a row-by-row basis in rolling-shutter mode.

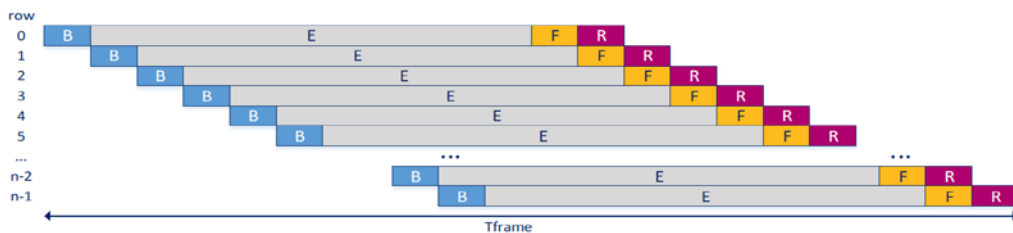

Rolling shutter row-by-row exposition and readout

Fast Frame Rates

With fast frame rates and high sensitivity, COSMOS is well suited to dynamic imaging applications. Further, the short readout times can enable quick decision making and analysis.

Frame rate at full resolution, High Speed Mode, Rolling Shutter		
	Resolution	Framerate
COSMOS-66	8120 x 8120	25
COSMOS-42	6500 x 6500	31
COSMOS-10	3260 x 3260	61

Frame rate at reduced frame size, Rolling Shutter ¹		
Aperture / Region Size	High Speed (14 bit)	High Dynamic Range (16 bit) ²
8120 x 8120	24	15
4096 X 4096	48	31
2048 X 2048	98	61
1600 x 1600	125	78
1024 x 1024	195	122
512 x 512	390	244
256 x 256	781	488

1. All frame rates based on 8K COSMOS
2. Frame rates for HDR mode assumes x1 CMS

Deep Cooling & Lifetime Vacuum

For many astronomical observations, long exposure times are needed, thus deep camera cooling is necessary to reduce the thermal dark current noise. However, large CMOS sensors with high speed readout in fact generate a large amount of heat, even compared to CCD sensors.

The COSMOS builds on Teledyne Imaging's industry-leading cooling performance to overcome this challenge, achieving below -25°C cooling with low dark current, as shown by the test pixel data.

This is further improved by our all-metal, hermetically sealed vacuum enclosure (protected by a lifetime warranty), preventing the outgassing or degradation problems of other cameras.

Hardware Interface

COSMOS makes use of CoaXPress for high-speed image transfer. COSMOS is designed to work with Teledyne Imaging's high-performance Xtium™-CXP PX8 to provide maximum throughput and ready-to-use image data.

COSMOS is not compatible with all CoaXPress frame grabbers as GENICAM is not supported.

However, it is specifically designed to work with Xtium with drivers and interfacing provided through PICam.



Key Parameters

CoaXPress 2.0 4-Lane CXP12

- 50 Gbps of data bandwidth
- Full data rate with 15m cable length
- Host computer requires a PCIe Gen 3.0 x8 slot
- 75-ohm coaxial cables required (provided)

USB 3.1 Gen 2

- 10 Gbps data bandwidth; up to 6.5 Gbps throughput
- USB-C connector
- 1m passive or 3/5m active or optical cable support
- Compatible with host native USB 3.1 Gen 2, (USB 3.0), and Thunderbolt 3

Software Interface

PICam API and SDK, from Teledyne Princeton Instruments, offers complete control over all cameras. Available for all 64-bit Windows and Linux systems, PICam configures the identified hardware by adjusting parameters within its interface. PICam allows for the ultimate flexibility, providing developers, scientists and integrators the ability to build their own control and user interface directly on top of the driver.

For those who require a "plug-and-go" system, LightField® Software allows for complete control of COSMOS on an ease of use platform. LightField software also includes simple, image post-processing software and a built-in, smart math engine to obtain the most from acquired data.





COSMOS™

LARGE AREA CMOS CAMERAS



teledyneprincetoninstruments.com

Main Office- (USA) Tel: +1 609.587.9797 pi.info@teledyne.com	China Tel: +86 157 2153 5343 pi.info.china@teledyne.com	France Tel: +33.1.70.38.19.00 EVR@teledyne.com
Germany Tel: + 49 (0) 89-660 779 3 pi.germany@teledyne.com	Japan Tel: +81.3.6709.0631 pi.nippon@teledyne.com	United Kingdom Tel: +44 (0) 7810 835 719 pi.info@teledyne.com

Teledyne Princeton Instruments has its corporate offices in Trenton, New Jersey, USA Teledyne Imaging reserves the right to make changes at any time without notice

Copyright © 2022 Teledyne Princeton Instruments, Inc. All rights reserved.
LightField is a registered trademark of Teledyne Princeton Instruments. Linux is the registered trademark of Linus Torvalds in the U.S. and other countries. LabVIEW is a registered trademark of National Instruments Corporation. CoaXPress is a registered trademark of trademark of Japan Industrial Imaging Association (JILA). Microsoft and Windows are registered trademarks of Microsoft Corporation in the United States and other countries. All other brand and product names are the trademarks or registered trademarks of their respective owners and manufacturers.