

Genie Nano-CL Series™

Camera User's Manual

Camera Link – Monochrome & Color Area Scan

sensors | cameras | frame grabbers | processors | software | vision solutions

Genie
Nano™



October 15, 2019
Rev: 0003
P/N: G3-C00M-USR00
www.teledynedalsa.com

 **TELEDYNE DALSA**
Everywhereyoulook™

Notice

© 2017 – 2019 Teledyne Digital Imaging Inc.

All information provided in this manual is believed to be accurate and reliable. No responsibility is assumed by Teledyne DALSA for its use. Teledyne DALSA reserves the right to make changes to this information without notice. Reproduction of this manual in whole or in part, by any means, is prohibited without prior permission having been obtained from Teledyne DALSA.

Microsoft and Windows are registered trademarks of Microsoft Corporation in the United States and other countries. Windows, Windows 7, Windows 10 are trademarks of Microsoft Corporation.

All other trademarks or intellectual property mentioned herein belong to their respective owners.

Document Date: October 15, 2019

Document Number: G3-C00M-USR00

About Teledyne DALSA, a business unit of Teledyne Digital Imaging Inc.

Teledyne DALSA is an international high performance semiconductor and Electronics Company that designs, develops, manufactures, and markets digital imaging products and solutions, in addition to providing wafer foundry services.

Teledyne DALSA Digital Imaging offers the widest range of machine vision components in the world. From industry-leading image sensors through powerful and sophisticated cameras, frame grabbers, vision processors and software to easy-to-use vision appliances and custom vision modules.

Contents

NANO-CL SERIES OVERVIEW	5
DESCRIPTION	5
<i>Genie Nano Overview</i>	5
<i>Camera Firmware</i>	5
MODEL PART NUMBERS	6
<i>Monochrome Camera Link Base Mode</i>	6
<i>Monochrome Camera Link DECA Mode</i>	6
<i>Color Camera Link Base Mode</i>	7
<i>Color Camera Link DECA Mode</i>	7
<i>Accessories</i>	8
HARDWARE AND SOFTWARE ENVIRONMENTS	9
<i>Frame Grabbers and Cabling</i>	9
<i>Software Platforms</i>	9
<i>Development Software for Camera Control</i>	9
<i>Camera Link Frame Grabber Requirement for the Nano-CL Family</i>	10
GENIE NANO SPECIFICATIONS	12
COMMON SPECIFICATIONS	12
<i>Sensor Cosmetic Specifications</i>	16
<i>Dynamic Range & Signal to Noise Ratio Test Conditions</i>	16
<i>EMI, Shock and Vibration Certifications</i>	17
<i>Mean Time between Failure (MTBF)</i>	18
NANO-CL SPECIFICATIONS: M2420 & C2420	19
<i>Firmware Files for Model M/C 2420</i>	20
NANO-CL SPECIFICATIONS: M4020 & C4020	20
<i>Firmware Files: for 5.1M and 12M Models</i>	21
Standard 2-tap Design	21
Standard 3-tap Design	21
NANO-CL SPECIFICATIONS: M2450 & C2450	22
<i>Firmware Files for Model M/C 2450</i>	23
<i>Spectral Responses</i>	23
NANO-CL SPECIFICATIONS: M4060 & C4060	24
<i>Firmware Files for Model M/C 4060</i>	25
<i>Spectral Responses</i>	25
NANO-CL SPECIFICATIONS: M4040 & C4040	26
<i>Firmware Files for Model M/C 4040</i>	27
<i>Spectral Responses</i>	27
NANO-CL SPECIFICATIONS: M4160, C4160	28
<i>Spectral Responses</i>	29
NANO-CL SPECIFICATIONS: M5100, C5100, M4090, C4090	30
<i>Spectral Response</i>	32
<i>Defective Pixel Specification for Models 5100/4090</i>	33
<i>Firmware Files for These Models</i>	34
NANO-CL INSTALLATION	35
QUICK START (USING A TELEDYNE DALSA FRAME GRABBER)	35
GENERAL INSTALLATION OVERVIEW	35

<i>Camera Firmware Updates</i>	35
THE CAMERA WORKS — NOW WHAT	36
NANO-CL CONNECTORS AND STATUS LED OVERVIEW	36
<i>Connectors</i>	36
<i>LED Indicators</i>	37
Camera Status LED Indicator	37
LED States on Power Up	37
PREVENTING OPERATIONAL FAULTS DUE TO ESD	38
OPERATIONAL REFERENCE	39
USING CAMEXPERT WITH GENIE NANO CAMERAS	39
<i>CamExpert Panes</i>	39
CamExpert View Parameters Option	40
<i>About the Device User ID</i>	40
CAMERA INFORMATION CATEGORY	41
<i>Camera Information Feature Descriptions</i>	41
<i>Power-up Configuration Dialog</i>	45
Camera Power-up Configuration	45
Load / Save Configuration	45
SENSOR CONTROL CATEGORY	46
<i>Sensor Control Feature Descriptions</i>	46
<i>Offset/Gain Control Details (On-Semi Python sensors)</i>	49
On-Semi Python Sensors Gain Stage Diagram	49
<i>OnSemi Sensor Artifacts with Fast Readout Mode</i>	49
Fast Readout Mode Artifacts Correction	50
<i>Exposure Alignment: Overview</i>	50
Synchronous Exposure Alignment	51
Reset Exposure Alignment	51
<i>Sensor Exposure Timing: OnSemi Python Models</i>	51
Trigger Characteristics: Start of Exposure	51
I/O CONTROL CATEGORY	52
<i>I/O Control Feature Descriptions</i>	53
I/O Module Block Diagram	55
Trigger Mode Details	55
Trigger Source Types (Trigger Mode=On)	55
Trigger Overlap: Feature Details	56
COUNTER AND TIMER CONTROL CATEGORY	61
<i>Counter and Timer Control Feature Description</i>	62
Counter and Timer Group Block Diagram	65
Example: Counter Start Source = OFF	65
Example: Counter Start Source = CounterEnd (itself)	66
Example: CounterStartSource = EVENT and Signal (Edge Base)	66
Example: CounterStartSource = Line (Edge Base) Example	67
Example: Counting Elapse Time	68
ADVANCED PROCESSING CONTROL CATEGORY	69
<i>Notes about Lens Shading Calibration</i>	70
<i>Advanced Processing Control Feature Descriptions</i>	71
Advanced Processing Group	71
Flat Field Correction Group	72
Lens Shading Correction Group	73
<i>Defective Pixel Replacement</i>	75
Example User Defective Pixel Map XML File	75
Monochrome Defective Pixel Replacement Algorithm Description	76
Color Defective Pixel Replacement Algorithm Description	77
IMAGE FORMAT CONTROL CATEGORY	78

<i>Image Format Control Feature Description</i>	78
<i>Width and Height Features for Partial Scan Control</i>	80
Vertical Cropping (Partial Scan)	80
Maximum Frame Rate Examples (Nano-CL-M/C 5100)	82
Maximum Frame Rate Examples (Nano-CL-M/C 4090)	83
Maximum Frame Rate Examples (Nano-CL-M/C 2450)	84
Maximum Frame Rate Examples (Nano-CL-M/C 4060)	84
Maximum Frame Rate Examples (Nano-CL-M/C 4040)	85
Horizontal Cropping (Partial Scan)	86
<i>Internal Test Pattern Generator</i>	87
TRANSPORT LAYER CONTROL CATEGORY	88
<i>Transport Layer Control Feature Descriptions</i>	88
FILE ACCESS CONTROL CATEGORY	90
<i>File Access Control Feature Descriptions</i>	90
<i>Updating Firmware via File Access in CamExpert</i>	93
<i>Overview of the deviceUserBuffer Feature</i>	93
TRANSFER CONTROL CATEGORY	94
<i>Transfer Control Feature Descriptions</i>	94
<i>GenICamAccess Control Feature</i>	94
IMPLEMENTING TRIGGER-TO-IMAGE RELIABILITY	95
OVERVIEW	95
<i>T2IR with Genie Nano</i>	95
NANO FEATURES FOR T2IR MONITORING	96
TECHNICAL SPECIFICATIONS	97
NOTES ON GENIE NANO IDENTIFICATION AND MECHANICAL	97
<i>Temperature Management</i>	97
MECHANICAL SPECIFICATIONS — NANO-CL MEDIUM CASE:	98
MECHANICAL SPECIFICATIONS — NANO-CL XL CASE:	99
SENSOR ALIGNMENT SPECIFICATION	100
I/O CONNECTOR AND PINOUT	101
<i>10-pin I/O Connector Pinout Details</i>	101
Camera DC Power Characteristics	101
I/O Mating Connector Specifications & Sources	102
<i>Power over Camera Link (PoCL) Support</i>	103
EC & FCC DECLARATIONS OF CONFORMITY	104
<i>Models M/C2420, M/C4020, M/C2450, M/C4040, M/C4060</i>	104
<i>Models M/C5100, M/C4090</i>	105
ADDITIONAL REFERENCE INFORMATION	106
CHOOSING A LENS WITH THE CORRECT IMAGE CIRCLE	106
<i>Lens Options for Models '2450'</i>	106
<i>Lens Options for Models '4060/4040'</i>	107
<i>Lens Options for CL Models 'M/C 5100' and 'M/C 4090</i>	107
<i>Additional Lens Parameters (application specific)</i>	108
OPTICAL CONSIDERATIONS	108
<i>Illumination</i>	108
<i>Light Sources</i>	109
<i>IR Cut-off Filters</i>	109
Nano Models with Built-in IR Cut-off Filters	109
Guidelines for Choosing IR Cut-off Filters	110
Back Focal Variance when using any Filter	111
LENS MODELING	112

<i>Magnification and Resolution</i>	112
SENSOR HANDLING INSTRUCTIONS	113
<i>Electrostatic Discharge and the Sensor</i>	113
<i>Protecting Against Dust, Oil and Scratches</i>	113
<i>Cleaning the Sensor Window</i>	114
RUGGEDIZED CABLE ACCESSORIES	114
<i>Cable Manufactures Contact Information</i>	114
<i>Cable Assembly G3-AIOC-BLUNT1M</i>	115
<i>Cable Assembly G3-AIOC-BLUNT2M</i>	116
<i>Cable Assembly G3-AIOC-BRKOUT2M</i>	118
<i>Nano Generic Power Supply with no I/O</i>	120
<i>Components Express Right-Angle Cable Assemblies</i>	121
Cable Assembly: Right-Angle I/O Bunt End	121
Cable Assembly: Right-Angle I/O to Euro Block	122
TROUBLESHOOTING	123
OVERVIEW	123
<i>Problem Type Summary</i>	123
Before Contacting Technical Support	123
DEVICE AVAILABLE WITH OPERATIONAL ISSUES	123
<i>Firmware Updates</i>	123
<i>Power Failure during a Firmware Update—Now What?</i>	124
<i>Cabling and Communication Issues</i>	124
<i>Recommended Hardware</i>	124
Cable Length Considerations	124
Nano-CL — Minimum horizontal Sync	125
<i>Camera is functional, frame rate is as expected, but image is black</i>	125
<i>Other Problems or Issues</i>	125
REVISION HISTORY	126
CONTACT INFORMATION	127
SALES INFORMATION	127
TECHNICAL SUPPORT	127

Nano-CL Series Overview

Description

The Genie Nano-CL Camera Link series provides affordable easy to use digital cameras specifically engineered for industrial imaging applications by using the industries' latest leading sensors such as the On-Semi Python series of global shutter active pixel-type CMOS image sensors. Cameras are available in a number of models implementing different sensors, image resolutions and feature sets, either in monochrome, monochrome NIR, or color (raw Bayer) versions.

Nano-CL supports the Teledyne DALSA Trigger-to-Image-Reliability framework to dependably capture and transfer images from the camera to the host PC.

Genie Nano Overview



- Supports Power Over Camera Link (PoCL) or an auxiliary power input
- Optimized, rugged design with a wider operating temperature
- Available in multiple sensors/resolutions, monochrome and color
- Visual camera multicolor status LED on back plate
- 1 CC signal lines via the camera link cable
- Flexible general purpose Counter and Timer functions available for internal and external controls
- Software and hardware Events available to support imaging applications
- Defective Pixel replacement available
- User Settings to store Defective Pixel Maps
- Lens Shading Correction Maps for lens vignetting
- Application development with the freely available Sopera™ LT software libraries
- Native Teledyne DALSA Trigger-to-Image Reliability design framework
- Refer to the Operation Reference and Technical Specifications section of the manual for full details
- Camera Link v2.1, GenICam GenCP compliant
- Supports Camera link Base configuration or 80-bit configuration and Full configuration

Camera Firmware

Teledyne DALSA Genie Nano camera firmware contains open source software provided under different open source software licenses. More information about these open source licenses can be found in the documentation that accompanies the firmware, which is available on the Teledyne DALSA website at www.teledynedalsa.com.

Firmware updates for Genie Nano are available for download from the Teledyne DALSA web site www.teledynedalsa.com/imaging/support/downloads. Choose Genie Nano-CL Firmware from the available download sections, then choose the zip file download specific to your camera model.

When using Sopera LT, update the camera firmware using CamExpert (see [File Access via the CamExpert Tool](#)). The Camera firmware can also be easily upgrade/downgrade within your own application via the API. The camera has a failsafe scheme which prevents unrecoverable camera errors even in the case of a power interruption.

Model Part Numbers

This manual covers the released Genie Nano-CL monochrome and color models summarized in the tables below. These tables list models in increasing resolution. Nano [common specifications](#) and details for each Genie Nano model follow this section.

Monochrome Camera Link Base Mode

Nano-CL Model Full Resolution	Sensor Size/Model	Lens	Part Number
M2420 2464 x 2056	Sony 5.1M (IMX264)	C-mount	G3-CM31-M2420
M4020 4112 x 3008	Sony 12M (IMX304)	C-mount	G3-CM31-M4020

Monochrome Camera Link DECA Mode

Nano-CL Model Full Resolution	Sensor Size/Model	Lens	Part Number
M2450 2448 x 2048	Sony 5.1M (IMX250)	C-mount	G3-CM30-M2450
M4060 4112 x 2176	Sony 8.9M (IMX255)	C-mount	G3-CM30-M4060
M4040 4112 x 3008	Sony 12M (IMX253)	C-mount	G3-CM30-M4040
M4160 4128 x 4128	E2V Emerald 16M (EV2S16M)	C-mount	G3-CM30-M4160
M4090 4096 x 4096	On-Semi 16M (Python 16K)	M42 mount	G3-CM10-M4095
M4090-NIR 4096 x 4096	On-Semi 16M (Python 16K)	M42 mount	G3-CM12-M4095
M5100 5120 x 5120	On-Semi 25M (Python 25K)	M42 mount	G3-CM10-M5105
M5100-NIR 5120 x 5120	On-Semi 25M (Python 25K)	M42 mount	G3-CM12-M5105





Color Camera Link Base Mode

Nano-CL Model Full Resolution	Sensor Size/Model	Lens	Part Number
C2420 2464 x 2056	Sony 5.1M (IMX264)	C-mount	G3-CC31-C2420
C4020 4112 x 3008	Sony 12M (IMX304)	C-mount	G3-CC31-C4020

Color Camera Link DECA Mode

Model Full Resolution	Sensor Size/Model	Lens	Part Number	Notes
<u>C2450</u> 2448 x 2048	Sony 5.1M (IMX250)	C-mount	G3-CC30-C2450	
			G3-CC30-C2450IF	with IR Cut-off Filter
<u>C4060</u> 4112 x 2176	Sony 8.9M (IMX255)	C-mount	G3-CC30-C4060	
			G3-CC30-C4060IF	with IR Cut-off Filter
<u>C4040</u> 4114 x 3008	Sony 12M (IMX253)	C-mount	G3-CC30-C4040	
			G3-CC30-C4040IF	with IR Cut-off Filter
C4160 4128 x 4128	E2V Emerald 16M (EV2S16M color)	C-mount	G3-CC30-C4160	
<u>C4090</u> 4096 x 4096	On-Semi 16M (Python 16K)	M42 mount	G3-CC10-C4095	
<u>C5100</u> 5120 x 5120	On-Semi 25M (Python 25K)	M42 mount	G3-CC10-C5105	

Accessories

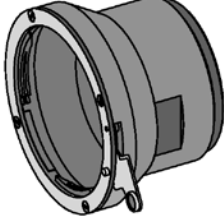
Nano Accessories & Cables (sold separately)		Order Number
<p>Mounting Bracket Plate</p> <p>(2 or 3 screw camera mount), with ¼ inch external device screw mount (also known as a tripod mount)</p>		<p>G3-AMNT-BRA01</p>
<p>I/O Blunt End Cable</p> <p>(1 meter Screw Retention to Flying Leads)</p> <p>(2 meter Screw Retention to Flying Leads)</p>		<p>G3-AIOC-BLUNT1M</p> <p>G3-AIOC-BLUNT2M</p>
<p>I/O Breakout Cable</p> <p>(2 meter Screw Retention to Euroblock connector)</p>		<p>G3-AIOC-BRKOUT2M</p>
<p>Generic 12 volt power supply for Genie Nano–Aux connector (Samtec 10-Pin) – 4 Meter length</p>		<p>G3-APWS-S10S04M</p>
<p>Nano-CL — M42 to F-mount (Nikon) adapter (same adapter as used with Genie TS)</p> <p><i>Note that there is no support for Nikon lens features such as focus and aperture motor controls.</i></p>		<p>G2-AM42-MOUNT4</p>

Right angle I/O cables and Ethernet cables (including combo evaluation packages) are available directly from our preferred source (see [Components Express Right-Angle Cable Assemblies](#)).

Hardware and Software Environments

The following describes suggested hardware and supported software for successful systems using the Nano-CL.

Frame Grabbers and Cabling

The Nano-CL has a Camera Link Pixel Clock of 85MHz. Teledyne DALSA Xtium series frame grabbers are recommended for error free acquisitions (contact sales for additional information).

Teledyne DALSA has also qualified 10 meter cables with the Teledyne DALSA Xtium frame grabber at 85MHz using Camera Link cables (end to end standard solutions of various lengths) from Components Express and Alysium, who also offer I/O signal solutions as described in this manual. See [Cable Manufactures Contact Information](#) for contact information.

Software Platforms

Platform	Notes
Support of GenICam GenCP	For camera setting
Support of GenICam File access implementation	File access support for firmware update
Support of GenICam XML schema version 1.1	
Support of Camera Link 1.2	
GenICam™ support — XML camera description file	Embedded within Genie Nano-CL

Development Software for Camera Control

Teledyne DALSA Software Platform for Microsoft Windows	
<p>Sapera LT for Windows — version 8.31 or later Includes Sapera Runtime and CamExpert. Provides everything you will need to develop imaging applications Sapera documentation provided in compiled HTML help, and Adobe Acrobat® (PDF)</p>	<p>Available for download http://www.teledynedalsa.com/imaging/support/</p>
<p>For software information for using the Nano-CL with Teledyne DALSA Frame grabbers or third party grabbers see: G3-ANCL02-V1: Getting Started with the Genie Nano-CL and Teledyne DALSA Frame Grabbers G3-ANCL01-V1: Getting Started with the Genie Nano-CL and 3rd Party Frame Grabbers http://www.teledynedalsa.com/en/support/documentation/app-notes/</p>	
Third Party Software Platforms	
GenICam GenCP Compliant Software And Tools	Contact your supplier

Camera Link Frame Grabber Requirement for the Nano-CL Family

Camera Controls	
Trigger Input	Using CC1 line
Communication Protocol	GenCP over the serial port (GenICam GenCP compliant software)
Camera Link Serial Baud Rate	9600 to 921600
Camera Link Tap Geometry	
<p>DECA Mode: 1x10_1Y</p> <p>On each cycle of the Camera Link pixel clock, the data for ten pixels is transmitted via the Camera Link interface. This is commonly referred to as a "ten tap" Camera Link configuration.</p>	
<p>Full Mode: 1x8_1Y</p> <p>On each cycle of the Camera Link pixel clock, the data for eight pixels is transmitted via the Camera Link interface. This is commonly referred to as an "eight tap" Camera Link configuration.</p>	

Camera Link Tap Geometry	
<p>Base Mode: 1x3_1Y</p> <p>On each cycle of the Camera Link pixel clock, the data for three pixels are transmitted via the Camera Link interface.</p>	
<p>Base Mode: 1x2_1Y</p> <p>On each cycle of the Camera Link pixel clock, the data for three pixels are transmitted via the Camera Link interface.</p>	
<p>Camera Link Pixel Clock</p>	<p>85MHz</p>

Genie Nano Specifications

The Nano common specifications listed first are followed by model specific tables of functional features and timing details.

Common Specifications

Camera Controls	
Communication Protocol	GenCP over the serial port (GenICam GenCP compliant software)
Camera Link Serial Baud Rate	9600 to 921600
Synchronization Modes	Free running, External triggered (Using CC1 line)
Exposure Control	Internal – Programmable via the camera API External – based on Trigger Width (using the CC1 line)
Exposure Time Maximum	16 sec
Exposure Modes	Programmable in increments of 1 μ s minimum time (in μ s) is model specific Pulse controlled via Trigger pulse width.
Camera Link CC Inputs	Support for CC1 (as trigger)
Features	
Reserved Private User Buffer	4 kB flash memory for OEM usage (<i>deviceUserBuffer</i>)
Flash memory	32 MB flash memory
Gain	In Sensor gain
Color model output	Color cameras support raw Bayer output
Defective Pixel Replacement	Up to 4096 entries
Counter and Timer	1 Counter and 1 Timer. User programmable, acquisition independent, with event generation, and can control Output I/O pins
Test image	Internal generator with choice of static and shifting patterns
User settings	Select factory default or either of two user saved camera configurations

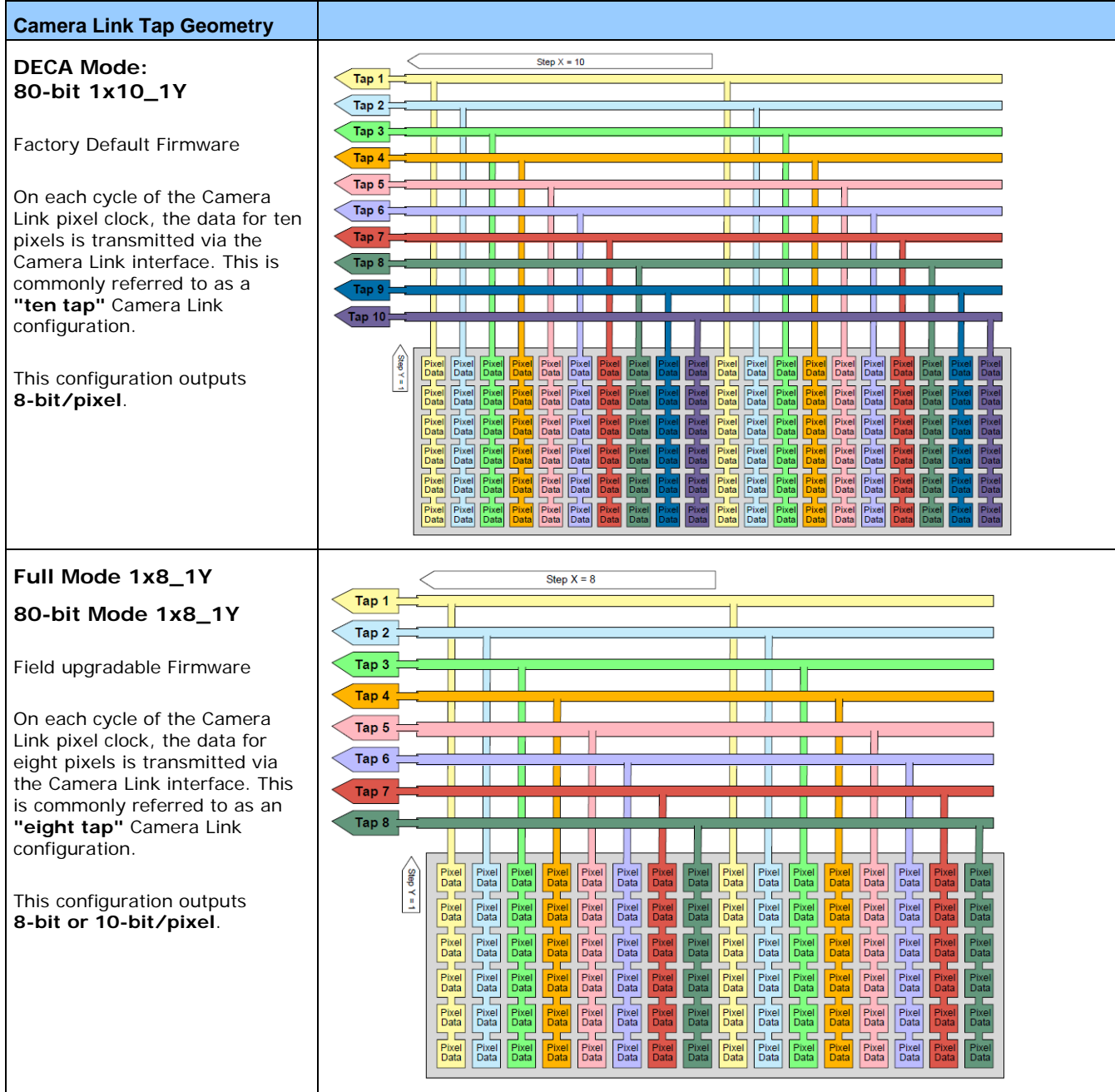

Full Mode 1x6_1Y
72-bit Mode 1x6_1Y

Field upgradable Firmware

On each cycle of the Camera Link pixel clock, the data for eight pixels is transmitted via the Camera Link interface. This Camera Link configuration is available with Camera Link specification 2.1.

This configuration outputs **8-bit or 12-bit/pixel**.

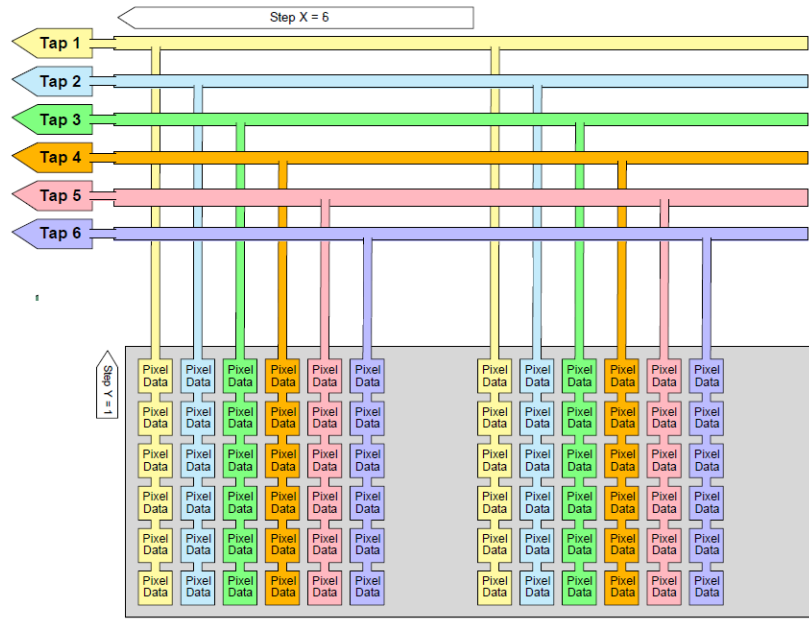

Base Mode: 1x3_1Y

On each cycle of the Camera Link pixel clock, the data for three pixels are transmitted via the Camera Link interface.

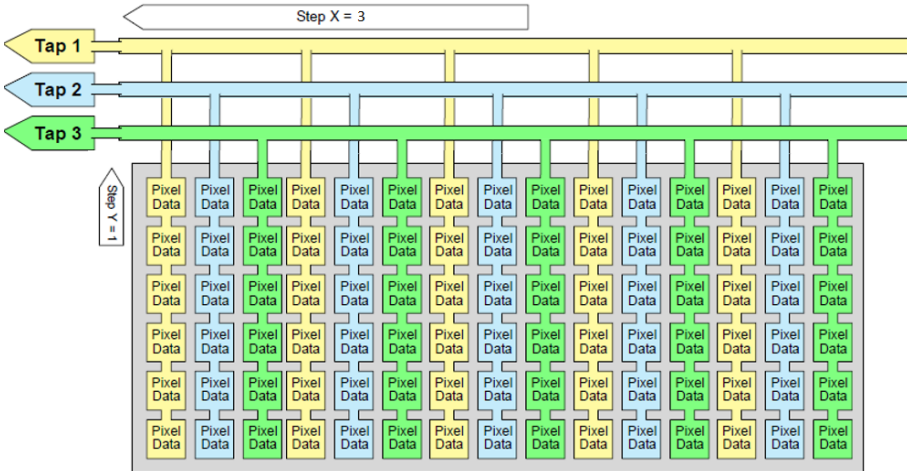

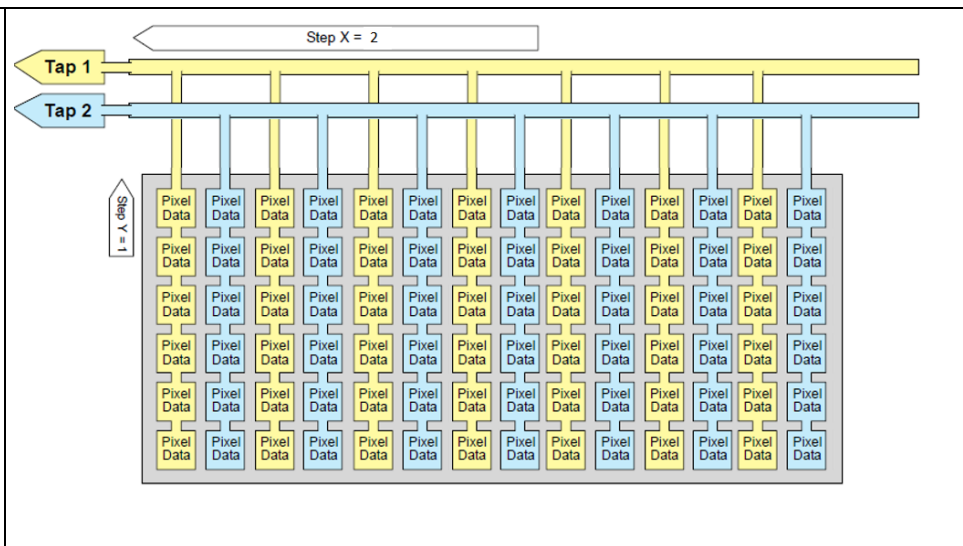
<p>Base Mode: 1x2_1Y</p> <p>On each cycle of the Camera Link pixel clock, the data for three pixels are transmitted via the Camera Link interface.</p>	
<p>Back Focal Distance</p>	
	<p>17.52 mm (C-mount with medium case models) 12 mm (M42 mount with XL case models)</p>
<p>Mechanical Interface</p>	
<p>Camera (L x H x W) see Mechanical Specifications — Nano-CL :</p>	<p><i>Medium Case:</i> 44 mm x 44 mm x 21 mm (without bar adapter and connectors) 44 mm x 44 mm x 39 mm (with lens adapter and connectors) <i>XL Case:</i> 38.3 mm x 59 mm x 59 mm</p>
<p>Mass (approximate value due to sensor variations)</p>	<p>Medium Case: 72g XL Case: ~ 163g</p>
<p>Camera Link Connector Type</p>	<p>Two SDR-26 connectors for DECA mode (80-bit) For Base configurations the second SDR-26 is not used</p>
<p>Power connector</p>	<p>10-pin I/O connector or via the SDR-26 Camera Link using PoCL</p>
<p>Electrical Interface</p>	
<p>Input Voltage</p>	<p>+10 to +36 Volts DC (+10%/- 10%) +9 to +56 Volts DC (Absolute min/max Range) on Auxiliary connector Supports the Power Over Camera Link standard (PoCL) on Models with medium casing. Note: requires both CL cables when using PoCL.</p>
<p>Power Dissipation (typical)</p>	<p>Nano-CL: 6.5W @ 24Vdc aux. (for the XL case)</p>
<p>Data Output</p>	<p>Camera Link</p>
<p>Environmental Conditions</p>	
<p>Operating Temperature (at camera front plate)</p>	<p>All Models: -20°C to +65°C (-4°F to +149°F) Any metallic camera mounting provides heat-sinking therefor reducing the internal temperature.</p>
<p>Operating Relative Humidity</p>	<p>10% to 80% non-condensing</p>
<p>Storage</p>	<p>-40°C to +80°C (-4°F to +176°F) temperature at 20% to 80% non-condensing relative humidity</p>
<p>Conformity</p>	<p>Camera Link v2.1, GenICam GenCP compliant</p>

Sensor Cosmetic Specifications

After Factory Calibration and/or Corrections are applied (if applicable — dependent on sensor)

Blemish Specifications	Maximum Number of Defects	Blemish Description
Hot/Dead Pixel defects	Typical 0.0025% Max 0.005%	Any pixel that deviates by $\pm 20\%$ from the average of neighboring pixels at 50% saturation including pixel stuck at 0 and maximum saturated value.
Spot defects	none	Grouping of more than 8 pixel defects within a sub-area of 3x3 pixels, to a maximum spot size of 7x7 pixels.
Clusters defects	none	Grouping of more than 5 single pixel defects in a 3x3 kernel.
Column defects	none	Vertical grouping of more than 10 contiguous pixel defects along a single column.
Row defects	none	Horizontal grouping of more than 10 contiguous pixel defects along a single row.

- **Test conditions**
 - Nominal light = illumination at 50% of saturation
 - Temperature of camera is 45°C
 - At exposures lower than 0.25 seconds
 - At nominal sensor gain (1x)

Dynamic Range & Signal to Noise Ratio Test Conditions

Dynamic Range Test Conditions

- Exposure 100 μ s
- 0% Full Light Level

SNR Test Conditions

- Exposure 2000 μ s
- 80% saturation

Specifications calculated according to EMVA-1288 standard, using white LED light

- For On-semi Python
 - Max saturated values: up to 10 millisecond (Gain1.0) for the 16M to 25M
- For Sony
 - Max saturated values: Max Pixel format bit depth - 1DN

EMI, Shock and Vibration Certifications

Compliance Directives	Standards ID	Overview
CE	EN61000-4-2 : 2008	Electrostatic discharge immunity test
	EN61000-4-3 : 2006 A1 : 2007 A2 : 2010	Radiated, radio-frequency, electromagnetic field immunity test
	EN61000-4-4 : 2004	Electrical fast transient/burst immunity test
	EN61000-4-5 : 2005	Surge immunity
	EN61000-4-6 : 2008	Immunity to conducted disturbances, induced by radio-frequency fields
	EN61000-4-8 : 2009	Power frequency magnetic field immunity
	EN61000-4-11 : 2004	Voltage variations immunity
	EN61000-6-2 : 2005	Electromagnetic immunity
	EN61000-6-4: 2007	Electromagnetic emissions
	CISPR 11: 2009 A1 : group 1 FCC, part 15, subpart B:2010	Limit: class A Conducted Emissions
CISPR 22 : 2008 Limit: class A	LAN port Conducted Emissions	
FCC	Part 15, class A	
RoHS	Compliance as per European directive 2011/65/EC	
For an image of Genie Nano certificates see "EC & FCC Declarations of Conformity" on page 104		
Vibration & Shock Tests	Test Levels (while operating)	Test Parameters
Random vibrations	Level 1: 2 grms 60 min. Level 2: 4 grms 45 min. Level 3: 6 grms 30 min.	Frequency range: 5 to 2000 Hz Directions: X, Y, and Z axes
Shocks	Level 1: 20 g / 11 ms Level 2: 30 g / 11 ms Level 3: 40 g / 60 ms	Shape: half-sine Number: 3 shocks (+) and 3 shocks (-) Directions: ±X, ±Y, and ±Z axes
Additional information concerning test conditions and methodologies is available on request.		

Mean Time between Failure (MTBF)

The analysis was carried out for operating temperatures varying from 0 to 80°C. The following table presents the predicted MTBF and failure rate values.

Camera Assembly			
Temperatures	MTBF (hours)	MTBF (years)	Failure Rate (Failure/10 ⁶ hours)
0	3514728	401.2	0.284517
20	2040096	232.9	0.490173
40	1005703	114.8	0.994329
60	434538	49.6	2.301294
80	177030	20.2	5.648757

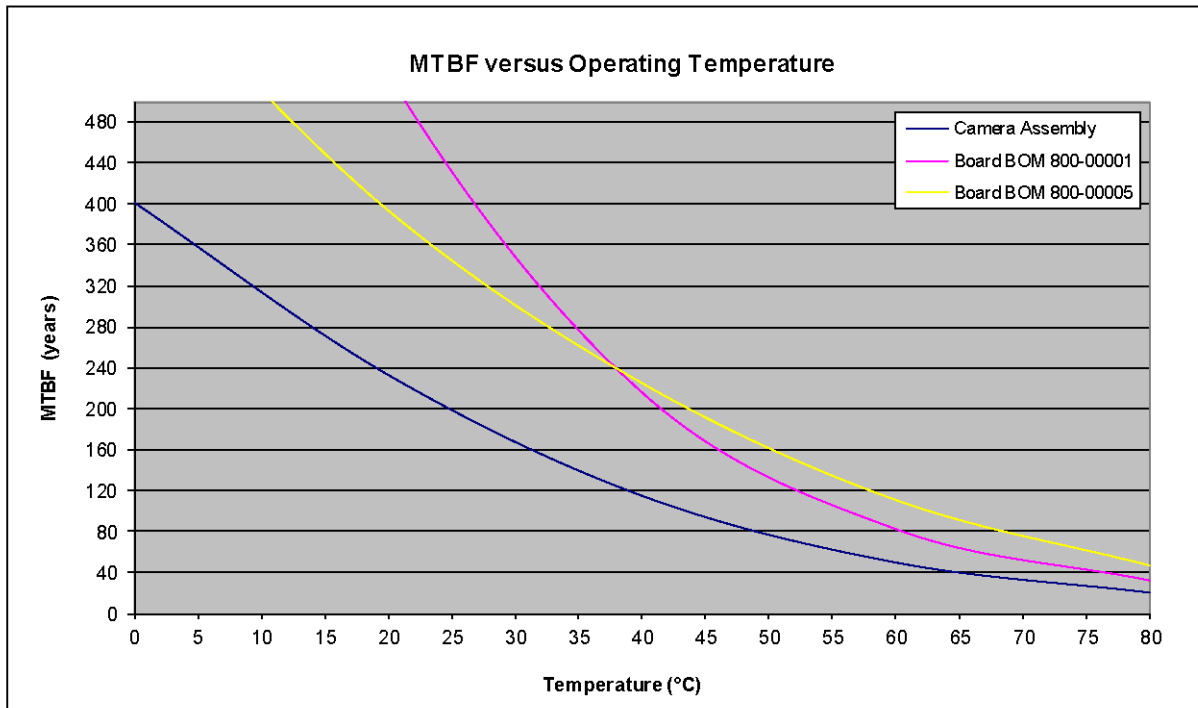

Nano-CL Specifications: M2420 & C2420

Model specific specifications and response graphics for the M/C2420 series are provided here. The response curves describe the sensor, excluding lens and light source characteristics.

Supported Features	M2420 & C2420
Resolution	2464 x 2056
Sensor	Sony IMX264 (5.1M)
Pixel Size	3.45 μm x 3.45 μm
Shutter Type	Full frame electronic global shutter function
Full Well charge	11ke (max)
Firmware options (field programmable)	Standard Design Bass 2-Tap Firmware
Maximum Frame Rate	32.5 fps
Pixel Format (Mono) 	Mono 8 & 12 bit
Pixel Format (Color) 	Bayer 8 & 12 bit
Trigger to Exposure Minimum delay (<i>Synchronous Exposure</i>)	Less than 1 μs
Trigger to Exposure Minimum delay (<i>Reset Exposure</i>)	29 μs
Trigger to Exposure Start jitter (<i>Synchronous Exposure</i>)	Up to 1 line time
Trigger to Exposure Start jitter (<i>Reset Exposure</i>)	0 μs
Exposure Time Minimum (see "exposureTimeActual" in Sensor Control)	28.2 μs
Horizontal Line Time:	14.5 μs
Min. Time from End of Exposure to Start of Next Exposure	145 μs
Readout Time	(Horizontal Line Time * NB Lines) + (2 * Horizontal Line Time at Maximum Sensor Width), in μs
Auto-Brightness	No
Black offset control	Yes (in DN)
Gain Control	In-sensor Analog Gain (1.0x to 251x)
Binning Support	No
Decimation Support	No
Defective Pixel Replacement	Yes - up to 2048 pixel position
Image Correction	No
Image Flip support	No
Multi-ROI Support	No
Output Dynamic Range (dB)	75.4 dB (12-bit mode)
SNR (dB)	39.6 dB

Firmware Files for Model M/C 2420

The latest firmware files for all Nano models are available on the Teledyne DALSA support web site: <http://www.teledynedalsa.com/imaging/support/downloads/firmware/>

The firmware files for this model are listed below. The xx denotes the current build number.

M/C 2420 – Camera Link Configuration: 2 Tap

- Genie_Nano-CL_Sony_IMX264_304_5M-12M_2Tap_Firmware_3CA21.xx.cbf

Nano-CL Specifications: M4020 & C4020

Model specific specifications and response graphics for the M/C4020 series are provided here. The response curves describe the sensor, excluding lens and light source characteristics.



Supported Features	M4020 & C4020	
Resolution	4112 x 3008	
Sensor	Sony IMX304 (12M)	
Pixel Size	3.45 μm x 3.45 μm	
Shutter Type	Full frame electronic global shutter function	
Full Well charge	11ke (max)	
Firmware options (field programmable)	Standard 2-Tap Base Design	Standard 3-Tap Base Design (factory default)
Maximum Frame Rate	15 fps	20 fps
Pixel Format (Mono) 	Mono 8 & 12 bit	Mono 8 bit
Pixel Format (Color) 	Bayer 8 & 12 bit	Bayer 8 bit
Camera Link Tap Geometry	1x2_1Y	1x3_1Y
Trigger to Exposure Minimum delay (<i>Synchronous Exposure</i>)	48μs	32μs
Trigger to Exposure Minimum delay (<i>Reset Exposure</i>)	< 1μs	
Trigger to Exposure Start jitter (<i>Synchronous Exposure</i>)	up to 1 line time	
Trigger to Exposure Start jitter (<i>Reset Exposure</i>)	0μs	
Exposure Time Minimum (see "exposureTimeActual" in Sensor Control)	38.4μs	30.4μs
Horizontal Line Time:	24.2μs	16.1μs
Min. Time from End of Exposure to Start of Next Exposure	252μs	163μs
Readout Time	(Horizontal Line Time * NB Lines) + (2 * Horizontal Line Time at Maximum Sensor Width), in μs	
Auto-Brightness	No	
Black offset control	Yes (in DN)	
Gain Control	In-sensor Analog Gain (1.0x to 251x)	
Binning Support	No	
Decimation Support	No	
Defective Pixel Replacement	Yes, up to 2048 pixel position	

Image Correction	No
Image Flip support	No
Multi-ROI Support	No
Output Dynamic Range (dB)	75.4 dB (12-bit mode)
SNR (dB)	39.6 dB

Firmware Files: for 5.1M and 12M Models

The latest firmware files for all Nano models are available on the Teledyne DALSA support web site: <http://www.teledynedalsa.com/imaging/support/downloads/firmware/>

The firmware files for this model are listed below. The xx denotes the current build number.

Standard 2-tap Design

Encompasses all features released in previous firmware versions along with new standard features for 8 or 12-bits output in Camera Link base configuration.

Genie Nano-CL: M2420, C2420, M4020, and C4020

- "Genie_Nano-CL_Sony_IMX264_304_5M-12M_2-Taps_Firmware_3CA21.xx.cbf"

Standard 3-tap Design



Encompasses all features released in previous firmware versions along with new standard features for 8-bits output in Camera Link base configuration.

Genie Nano-CL: M4020, and C4020 ONLY

- "Genie_Nano-CL_Sony_IMX304_12M_3-Taps_Base_Firmware_3CA21.xx.cbf"

Nano-CL Specifications: M2450 & C2450

Model specific specifications and response graphics for the M/C2450 series are provided here. The response curves describe the sensor, excluding lens and light source characteristics.

Supported Features	M2450 & C2450	
Resolution	2464 x 2056	
Sensor	Sony IMX250 (5.1M)	
Pixel Size	3.45 μm x 3.45 μm	
Shutter Type	Full frame electronic global shutter function	
Full Well charge	11ke (max)	
Sensitivity to Saturation	1x	
Firmware options (field programmable)	Standard Design Full 6-Taps Firmware	High Speed Design 80-bits-10Taps Firmware (factory default)
Maximum Frame Rate	TBA	141.8 fps
Pixel Format (Mono) 	Mono 8 & 12 bit	Mono 8 bit
Pixel Format (Color) 	Bayer 8 & 12 bit	Bayer 8 bit
Trigger to Exposure Minimum delay (<i>Synchronous Exposure</i>)	2 line time = 6.74 μs	
Trigger to Exposure Minimum delay (<i>Reset Exposure</i>)	0.05 μs	
Trigger to Exposure Start jitter (<i>Synchronous Exposure</i>)	0 to 3.37 μs (i.e. up to 1 line time)	
Trigger to Exposure Start jitter (<i>Reset Exposure</i>)	0 μs	
Exposure Time Minimum (see "exposureTimeActual" in Sensor Control)	3.37 + 13.73 = 17.10 μs	
Horizontal Line Time:	TBA	3.37 μs
Min. Time from End of Exposure to Start of Next Exposure	TBA	30 μs
Readout Time	1 Line Time*(number of lines + 23)	
Auto-Brightness	No	
Black offset control	Yes (in DN)	
Gain Control	In-sensor Analog Gain (1.0x to 251x) Digital Gain (1x to 4x in 0.1 steps)	
Binning Support	No	
Decimation Support	No	
Defective Pixel Replacement	Yes	
Image Correction	No	
Image Flip support	No	
Multi-ROI Support	No	
Output Dynamic Range (dB)	75.4 dB (12-bit mode)	
SNR (dB)	39.6 dB	

Firmware Files for Model M/C 2450

The latest firmware files for all Nano models are available on the Teledyne DALSA support web site: <http://www.teledynedalsa.com/imaging/support/downloads/firmware/>

The firmware files for this model are listed below. The xx denotes the current build number.

M/C 2450 – Camera Link Configuration: 80-bit 10 Tap (factory default)

- Genie_Nano-CL_Sony_IMX25x_5M-9M-12M_80-bits-10Tap_Firmware_2CA21.xxx.cbf

Spectral Responses

The response curves describe the sensor, excluding lens and light source characteristics.

Model M2450

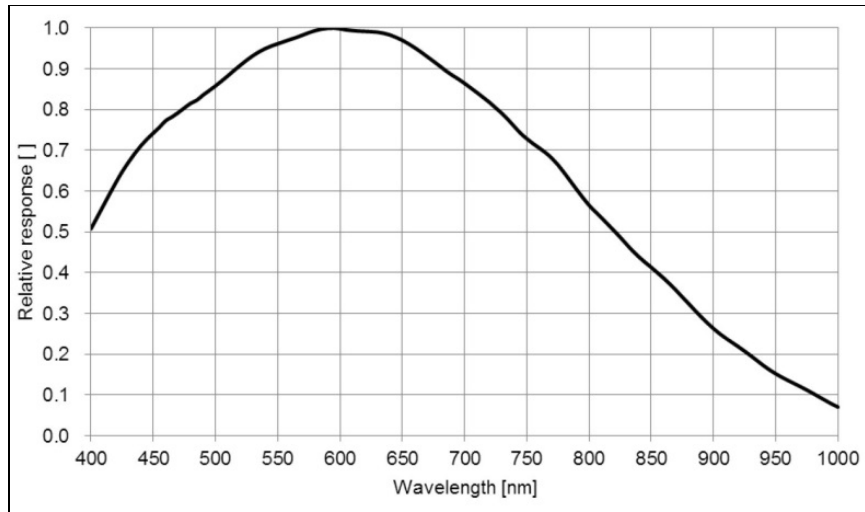

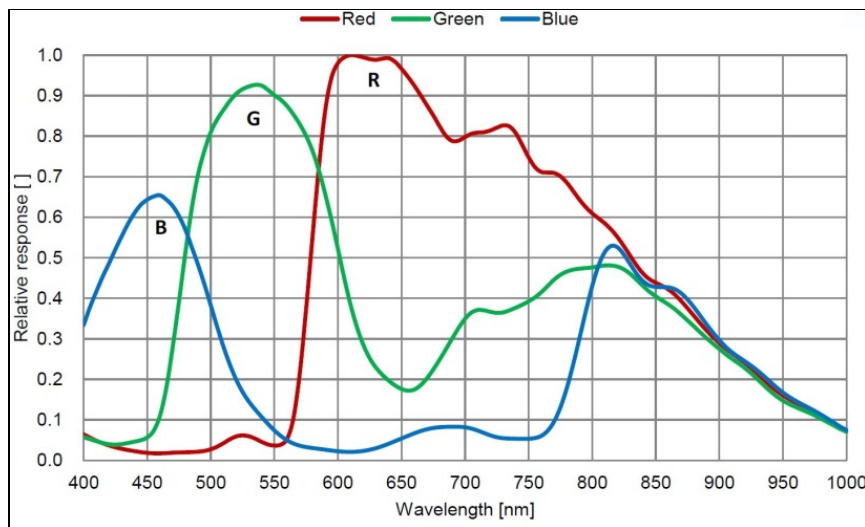

Model C2450



Nano-CL Specifications: M4060 & C4060

Model specific specifications and response graphics for the M/C4060 series are provided here. The response curves describe the sensor, excluding lens and light source characteristics.

Supported Features	M4060 & C4060	
Resolution	4112 x 2176	
Sensor	Sony IMX255 (8.9M)	
Pixel Size	3.45 μm x 3.45 μm	
Shutter Type	Full frame electronic global shutter function	
Full Well charge	11ke (max)	
Sensitivity to Saturation	4x	
Firmware options (field programmable)	Standard Design Full 6-Taps Firmware	High Speed Design 80-bits-10Taps Firmware (factory default)
Maximum Frame Rate (full frame)	TBD	87.6 fps
Pixel Format (Mono) 	Mono 8 & 12 bit	Mono 8 bit
Pixel Format (Color) 	Bayer 8 & 12 bit	Bayer 8 bit
Trigger to Exposure Minimum delay (<i>Synchronous Exposure</i>)	2 Line Time — 10.22 μs	
Trigger to Exposure Minimum delay (<i>Reset Exposure</i>)	0.05 μs	
Trigger to Exposure Start jitter (<i>Synchronous Exposure</i>)	0 to 5.11 μs (i.e. up to 1 line time)	
Trigger to Exposure Start jitter (<i>Reset Exposure</i>)	0 μs	
Exposure Time Minimum (see "exposureTimeActual" in Sensor Control)	5.11 + 14.26 = 19.37 μs	
Horizontal Line Time:	5.11 μs	
Min. Time from End of Exposure to Start of Next Exposure	TBA	108 μs
Readout Time	1 Line Time* (number of lines + 28)	
Auto-Brightness	No	
Black offset control	Yes (in DN)	
Gain Control	In-sensor Analog Gain (1.0x to 251x) Digital Gain (1x to 4x in 0.1 steps)	
Binning Support	No	
Decimation Support	No	
Defective Pixel Replacement	Yes	
Image Correction	No	
Image Flip support	No	
Multi-ROI Support	No	
Output Dynamic Range (dB)	76.4 dB (12-bit mode)	
SNR (dB)	39.3 dB	

Firmware Files for Model M/C 4060

The latest firmware files for all Nano models are available on the Teledyne DALSA support web site: <http://www.teledynedalsa.com/imaging/support/downloads/firmware/>

The firmware files for this model are listed below. The xx denotes the current build number.

M/C 4060 – Camera Link Configuration: 80-bit 10 Tap (factory default)

- Genie_Nano-CL_Sony_IMX25x_5M-9M-12M_80-bits-10Tap_Firmware_2CA21.xxx.cbf

Spectral Responses

The response curves describe the sensor, excluding lens and light source characteristics.

Models M4060

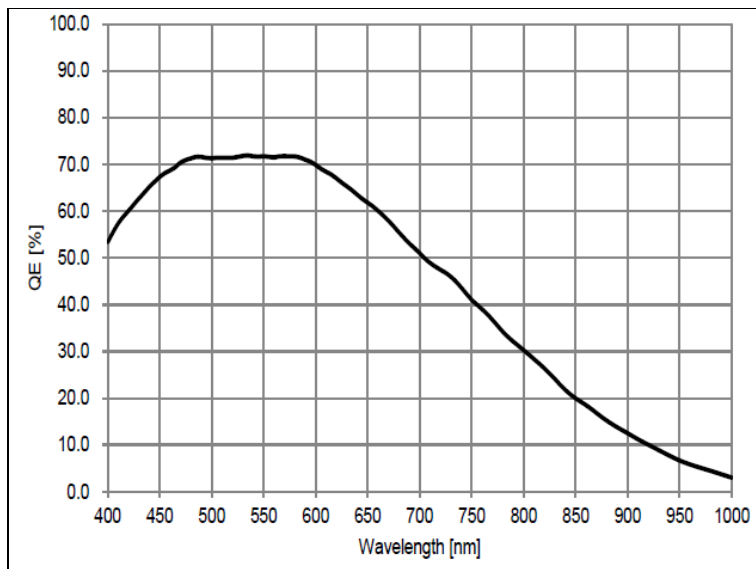

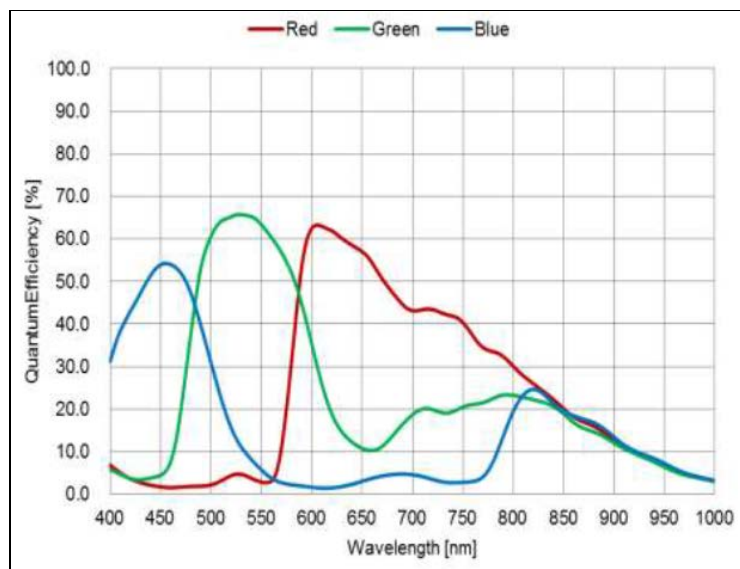

Models C4060



Nano-CL Specifications: M4040 & C4040

Model specific specifications and response graphics for the M/C4040 series are provided here. The response curves describe the sensor, excluding lens and light source characteristics.

Supported Features	M4040 & C4040	
Resolution	4112 x 3008	
Sensor	Sony IMX253 (12M)	
Pixel Size	3.45 μm x 3.45 μm	
Shutter Type	Full frame electronic global shutter function	
Full Well charge	11ke (max)	
Sensitivity to Saturation	4x	
Firmware options (field programmable)	Standard Design Full 6-Taps Firmware	High Speed Design 80-bits-10Taps Firmware (factory default)
Maximum Frame Rate (full frame)	TBA	63.8 fps
Pixel Format (Mono) 	Mono 8 & 12 bit	Mono 8 bit
Pixel Format (Color) 	Bayer 8 & 12 bit	Bayer 8 bit
Trigger to Exposure Minimum delay (<i>Synchronous Exposure</i>)	2 Line Time — 10.22 μs	
Trigger to Exposure Minimum delay (<i>Reset Exposure</i>)	0.05 μs	
Trigger to Exposure Start jitter (<i>Synchronous Exposure</i>)	0 to 5.11 μs (i.e. up to 1 line time)	
Trigger to Exposure Start jitter (<i>Reset Exposure</i>)	0 μs	
Exposure Time Minimum (see "exposureTimeActual" in Sensor Control)	5.11 + 14.26 = 19.37 μs	
Horizontal Line Time:	5.11 μs	
Min. Time from End of Exposure to Start of Next Exposure	TBA	108 μs
Readout Time	1 Line Time* (number of lines + 28)	
Auto-Brightness	No	
Black offset control	Yes (in DN)	
Gain Control	In-sensor Analog Gain (1.0x to 251x) Digital Gain (1x to 4x in 0.1 steps)	
Binning Support	No	
Decimation Support	No	
Defective Pixel Replacement	Yes	
Image Correction	No	
Image Flip support	No	
Multi-ROI Support	No	
Output Dynamic Range (dB)	76.4 dB (12-bit mode)	
SNR (dB)	39.3 dB	

Firmware Files for Model M/C 4040

The latest firmware files for all Nano models are available on the Teledyne DALSA support web site: <http://www.teledynedalsa.com/imaging/support/downloads/firmware/>

The firmware files for this model are listed below. The xx denotes the current build number.

M/C 4040 – Camera Link Configuration: 80-bit 10 Tap (factory default)

- Genie_Nano-CL_Sony_IMX25x_5M-9M-12M_80-bits-10Tap_Firmware_2CA21.xxx.cbf

Spectral Responses

The response curves describe the sensor, excluding lens and light source characteristics.

Models M4040

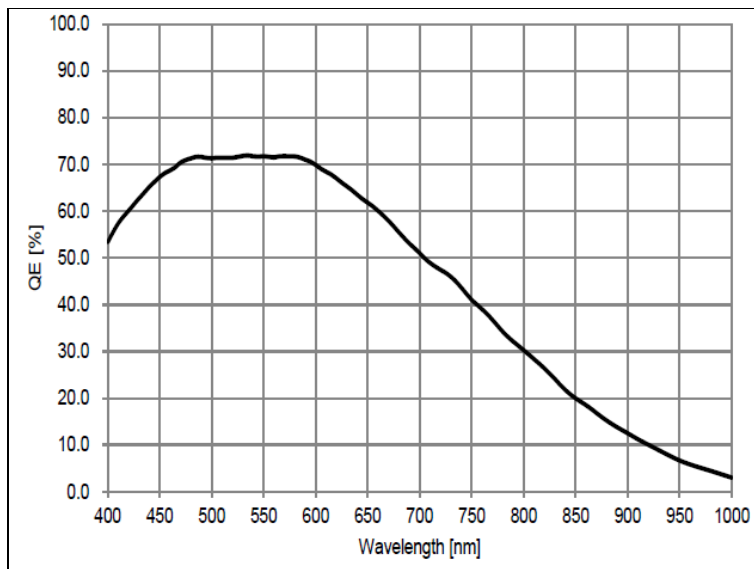

Models C4040

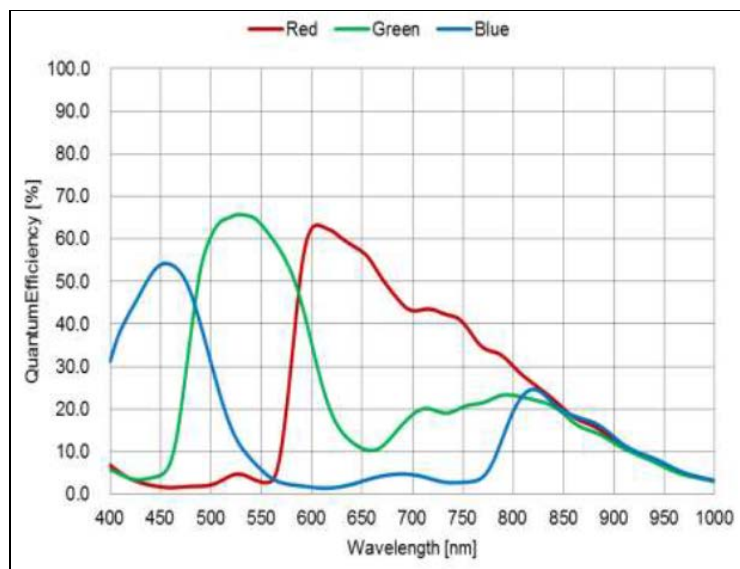

Nano-CL Specifications: M4160, C4160

Model specific specifications and response graphics for the Teledyne E2V Emerald EV2S16M (16M) series are provided here. The response curve describes the sensor, excluding lens and light source characteristics.

Camera Models	Nano-CL-M4160	Nano-CL-C4160
Resolution	4128 x 4128	
Sensor	Teledyne E2V Emerald EV2S16M	
Pixel Size	2.8 μm x 2.8 μm	
Shutter	Full frame electronic global shutter function	
Full Well charge	6645 e ⁻ (max)	
Camera Link DECA Mode 8-bit Firmware (80 bit CL configuration)	10 Taps of 8-bit Monochrome (1X10-1Y)	
Max. Frame Rate	47.3 fps	
Pixel Format	Mono 8-bit	Bayer 8-bit
Synchronization	Via external trigger signal or free run	
Exposure Control	Internal - Programmable via the camera API External – Based on Trigger Width	
Trigger to Exposure Minimum delay (Synchronous Exposure)	2 Line Time + 5 μs \rightarrow 15.2 μs (tentative)	
Trigger to Exposure Minimum delay (Reset Exposure)	N/A	
Trigger to Exposure Start jitter (Synchronous Exposure)	0 μs	
Trigger to Exposure Start jitter (Reset Exposure)	N/A	
Exposure Time Minimum	24 μsec	
Exposure Time Maximum	16 sec	
Horizontal Line Time:	μs	
Min. Time from End of Exposure to Start of Next Exposure	μs	
Readout Time		
Auto-Brightness	y / n	
Black offset control	y / n (in DN)	
Gain Control	In-sensor Analog Gain (1x, 1.5x, 2x, 3x, 4x, 6x and 8x) Digital Gain (1x to 4x in 0.1 steps)	
Binning Support	No	
Decimation Support	No	
Defective Pixel Replacement	Yes	
Image Correction	Lens Shading correction (Factory and 2 User Defined entry)	
Image Flip support	No	
Multi-ROI Support	No	
Output Dynamic Range (dB)	59.1 dB	
SNR (dB)	37.2 (in 8-bits)	

Spectral Responses

The response curve describes the sensor, excluding lens and light source characteristics.

Monochrome Sensor:

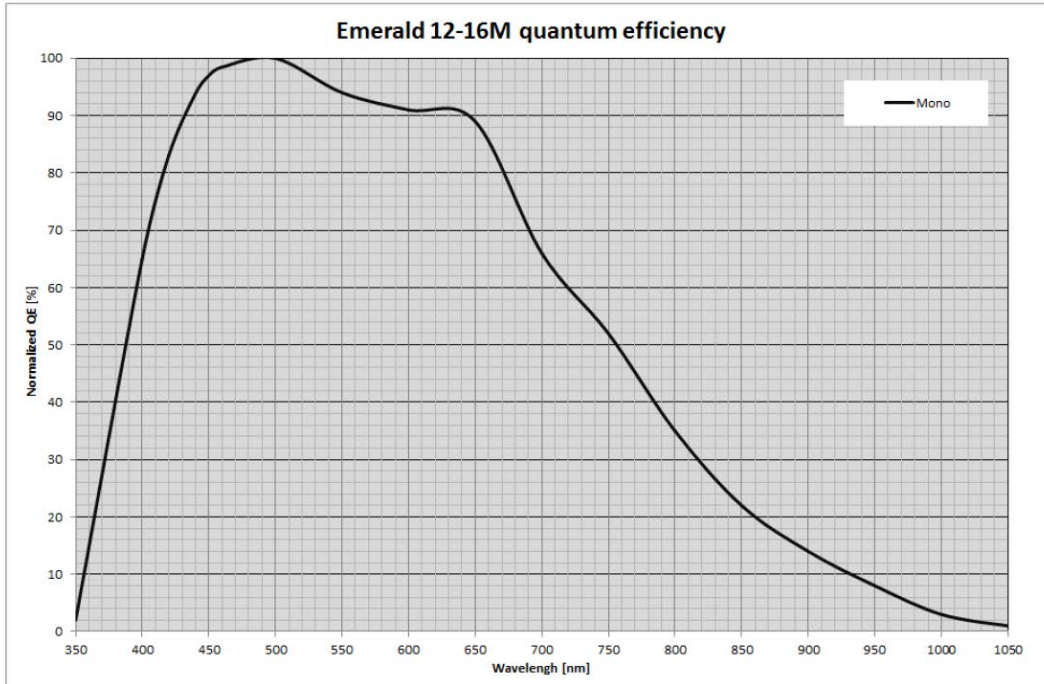

EV2S12M-16M Quantum Efficiency for mono version

Bayer Color Sensor:

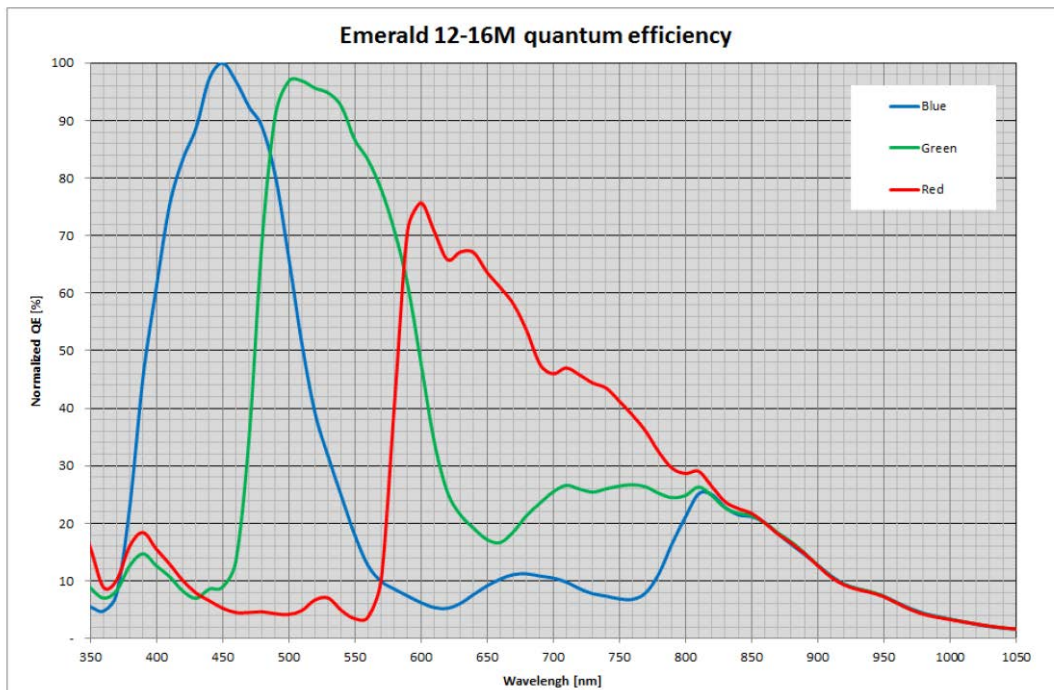

EV2S12M-16M Quantum Efficiency for color version

Nano-CL Specifications: M5100, C5100, M4090, C4090

Model specific specifications and response graphics for the On-Semi Python (25K & 16K) series are provided here. The response curves describe the sensor, excluding lens and light source characteristics.



Supported Features	M5100 & C5100		M4090 & C4090	
Resolution	5120 x 5120		4096 x 4096	
Sensor	On-Semi Python25K (25M)		On-Semi Python16K (16M)	
Pixel Size	4.5 µm x 4.5 µm			
Shutter Type	Full frame electronic global shutter function			
Full Well charge	12ke (max)			
Firmware options (field programmable)	Standard Design 80-bits-8Tap Firmware	High Speed Design 80-bits-10Tap Firmware (factory default)	Standard Design 80-bits-8Tap Firmware	High Speed Design 80-bits-10Tap Firmware (factory default)
Maximum Frame Rate	25.5 fps	32.0 fps	36.0 fps	46.8 fps
Pixel Format (Mono) 	Mono 8 & 10 bit	Mono 8 bit	Mono 8 & 10 bit	Mono 8 bit
Pixel Format (Color) 	Bayer 8 & 10 bit	Bayer 8 bit	Bayer 8 & 10 bit	Bayer 8 bit
Trigger to Exposure Minimum delay (<i>Synchronous Exposure</i>)	4 µs			
Trigger to Exposure Minimum delay (<i>Reset Exposure</i>)	4 µs			
Trigger to Exposure Start jitter (<i>Synchronous Exposure</i>)	Up to 1 line time			
Trigger to Exposure Start jitter (<i>Reset Exposure</i>)	0 µs			
Exposure Time Minimum (see "exposureTimeActual" in Sensor Control)	34 µs			
Horizontal Line Time: Normal Mode ¶¶	33.1 µs	16.55 µs	29.55 µs	14.78 µs
Horizontal Line Time: Fast Readout ¶¶	19.1 µs	9.56 µs	15.55 µs	7.78 µs
Min. Time from End of Exposure to Start of Next Exposure	Normal Readout: 120 us Fast Readout: 92 us	Normal Readout: 79 us Fast Readout: 65 us	Normal Readout: 120 us Fast Readout: 92 us	Normal Readout: 79 us Fast Readout: 65 us
Readout Time	(Horizontal Line Time * NB Lines) + (2 * Horizontal Line Time at Maximum Sensor Width), in µs			
Auto-Brightness	No			
Black offset control	Yes (in DN)			
Gain Control	In-sensor Analog Gain (1.0x to 3.17x) in 4 steps (1.0x, 1.26x, 2.87x, 3.17x)			
Binning Support	No			
Decimation Support	No			
Defective Pixel Replacement	Yes			
Image Correction	Flat Line Correction (Factory and 4 User Defined entries) Lens Shading correction (Factory and 1 User Defined entry) Noise Reduction (monochrome models only)			

Image Flip support	No			
Multi-ROI Support	No			
Output Dynamic Range (dB)	55.3	TBD	55.3	TBD
SNR (dB)	39.4	39.6	39.4	39.6

‡‡ Horizontal Line Time: Table Values and Formulas

Values stated in the table are calculated for the maximum sensor widths, specifically:

- Model M5100=5120 pixels
- Model M4090=4096 pixels

The following formulas describe **Horizontal Line Time**. Note that in “Fast Readout” mode, the line time does not reduce for widths below 4032 pixels, thus no need to calculate applicable time values for shorter lines.

- Horizontal line time (Standard Firmware, Normal mode) = $\frac{\left(\frac{width}{4}\right) + 1104}{72}$
- Horizontal line time** (Standard Firmware, Fast Readout mode) = $\frac{\left(\frac{width}{4}\right) + 96}{72}$
- Horizontal line time (High Speed Firmware, Normal mode) = $\frac{\left(\frac{width}{8}\right) + 552}{72}$
- Horizontal line time** (High Speed Firmware, Fast Readout mode) = $\frac{\left(\frac{width}{8}\right) + 48}{72}$

Spectral Response

On-Semi Python Series — Monochrome and NIR

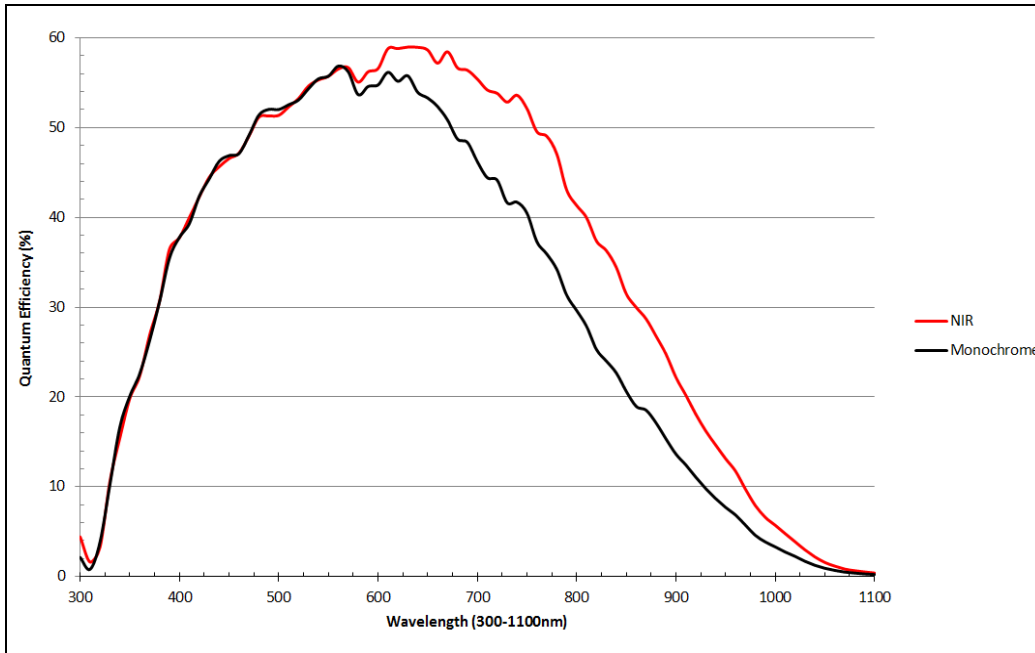

On-Semi Python Series — Bayer Color

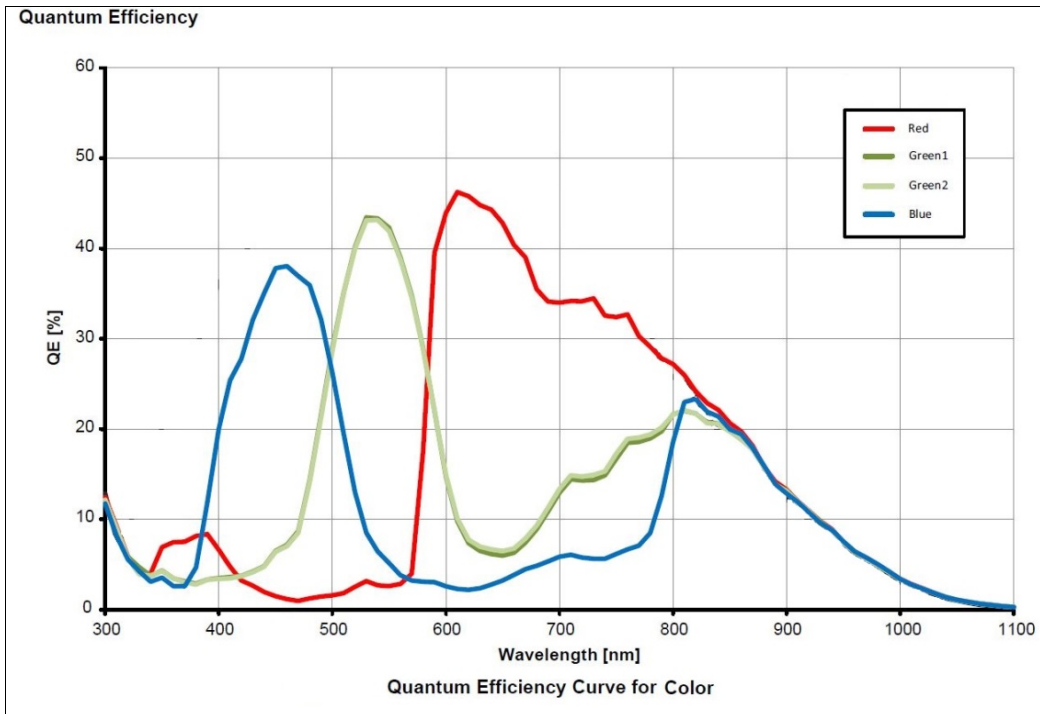

Defective Pixel Specification for Models 5100/4090

These defective pixel specifications in the following table are as published by the sensor manufacturer. Genie Nano cameras apply defective pixel corrections to improve the camera performance.

Defective Pixels (max: 1000)	Number of defective pixels allowed in the full window size of 5120 x 5120 (i.e. model 5100).
	For mono devices: A defective pixel is defined as a pixel which has a response that deviates 102 LSB10 in a dark image or a corrected gray image, or a saturated image, from the local median of the neighboring pixels in a 7 x 7 block.
	For color devices: The pixels are divided per color channels (R, G1, G2, B) and then calculated with the same methodology as mono devices.
	The defective pixels in dark, gray and saturated images are stored a in a global defect map. The limit is applied to the global defect map.
Defective Column 0 defective columns allowed	Number of defective columns in the full window size of 5120 x 5120 derived from dark, half scale and saturated image.
	For Mono devices: A bad column is defined as a column which has a response that deviates 48 LSB10 in a dark image, or a corrected gray or a saturated image, from the local median of 11 neighboring columns (+/- 5 left/right columns).
	For Color devices: The pixels are divided per color channels (R, G1, G2, B) and then calculated with the same methodology as mono devices.
Defective Row 0 defective rows allowed	Number of defective rows in the full window size of 5120 x 5120 derived from dark, half scale and saturated image.
	For Mono devices: A bad row is defined as a row which has a response that deviates 48 LSB10 in a dark image, or a corrected gray or a saturated image, from the local median of 11 neighboring rows (+/- 5 top/bottom rows).
	For Color devices: The pixels are divided per color channels (R, G1, G2, B) and then calculated with the same methodology as mono devices.
<i>continued next page</i>	

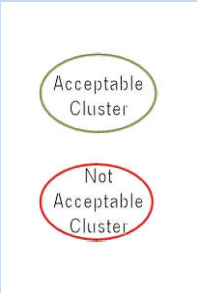
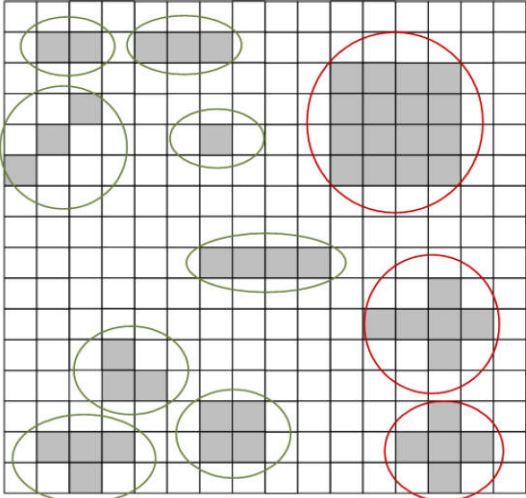
<p>Defective Cluster Definition</p> 	<p>Number of clusters allowed in the full window size of 5120 X 5120. A cluster is defined as a group of neighboring defective pixels (top, Bottom side, not diagonal), derived from the global defect map.</p> <p>For color devices: The pixels are divided per color channels (R, G1, G2, B) and then calculated with the same methodology as mono devices.</p> <p>Refer to the graphic below: The number of defective pixels in one cluster is the class (F) of the cluster:</p> <p>F2 (max 5): 2 defective pixels in the cluster F3 (max 4): 3 defective pixels in the cluster F4 (max 3): 4 defective pixels in the cluster F5 (max 0): 5 or more defective pixels in the cluster</p> 
--	--

Firmware Files for These Models

The latest firmware files for all Nano models are available on the Teledyne DALSA support web site: <http://www.teledynedalsa.com/imaging/support/downloads/firmware/>

The firmware files for these models are listed below. The xx denotes the current build number.

M4090, C4090, M5100, C5100 – Camera Link Configuration: 80-bit 10 Tap (factory default)

- High Speed Design – 80-bit 10 Tap
Genie_Nano-CL_OnSemi_Python_16M-25M_HSD_80-bits-10Tap_Firmware_1CA21.xx.cbf

M4090, C4090, M5100, C5100 – Camera Link Full Configuration: 8 Tap (field optional)

- Standard Design – 8 or 10-bit x 8 Tap
Genie_Nano-CL_OnSemi_Python_16M-25M_STD_80-bits-8Tap_Firmware_1CA21.xx.cbf

Nano-CL Installation

If you are familiar with Camera Link cameras and Teledyne DALSA frame grabbers, follow these steps to quickly install and acquire images with Genie Nano-CL and the CamExpert tool provided with Sapera LT in a Windows OS system.

Quick Start (using a Teledyne DALSA Frame Grabber)

- Install Sapera 8.31 (or later). Use the Full SDK version with support for Teledyne DALSA frame grabber boards.
- Install the Teledyne DALSA frame grabber board along with its driver for 10-Tap 8-bit support. This will match the default firmware loaded in the Nano-CL.
- Start [CamExpert](#) and configure frame buffer, data Taps, and frame rate parameters to match the Nano-CL model being used. Do not configure for an external trigger.
- Connect the Nano-CL with camera link cables that support PoCL. Both camera link cables connected to the frame grabber must be used for PoCL.
- Enable PoCL by its frame grabber feature. If not using PoCL connect power to the Nano-CL via its I/O connector.
- When the Nano-CL boots, CamExpert will read and display the camera features available with that model.
- Refer to the section [Transport Layer Control Category](#) to configure the camera's camera link settings.
- The Nano-CL status **LED has changed to flashing green**, indicating it is in free running acquisition mode. See [LED States on Power Up](#) for all status LED conditions.
- From the Nano-CL Image Format Feature Category, select the *Moving Grey Diagonal Ramp* test pattern from the *Test Image Selector* Parameter.
- Click grab. You will see the moving pattern in the CamExpert display window.
- If a camera lens is attached, turn off the test pattern and grab live again. Adjust the lens aperture plus Focus, and/or adjust the Nano [Exposure Time](#) and frame rate as required.

General Installation Overview

Connecting a Nano-CL to a frame grabber is similar whether using a Teledyne DALSA frame grabber board with Sapera LT SDK or a third party frame grabber with its own SDK.

Teledyne DALSA has 2 application notes which cover in detail the installation of a Genie Nano-CL. From our web site <http://www.teledynedalsa.com/imaging/knowledge-center/appnotes/> download one of these getting started guides as required:

- See "*G3-ANCL02-Getting Started with Genie Nano-CL and Teledyne Frame Grabbers.pdf*"
- See "*G3-ANCL01-Getting Started with Genie Nano-CL and 3rd Party Frame Grabbers.pdf*"

Camera Firmware Updates

Under Windows, the user can upload new firmware, using the [File Access Control](#) features provided by the Sapera CamExpert tool.

Download the latest firmware version released for any Nano-CL model from the Teledyne DALSA support web page: <http://www.teledynedalsa.com/imaging/support/downloads/firmware/>

The Camera Works — Now What

Consult this manual for detailed Nano-CL feature descriptions, as you write, debug and optimize your imaging application. Consult the frame grabber manual for all board control features.

Nano-CL Connectors and Status LED Overview

Connectors

The Nano-CL has three connectors:

- A **10 pin I/O** connector for camera power, plus trigger, strobe and general I/O signals. The connector supports a retention latch, while alternately the Nano-CL case supports using an I/O cable with thumbscrews. Teledyne DALSA provides optional cables for purchase (see Accessories). Also see 10-pin I/O Connector Pinout Details for pin out specifications.
- Two standard miniature SDR-26 Camera Link connectors. Use a frame grabber with SDR-26 connectors to simplify cabling. See [Components Express Contact Information](#) for a wide variety of PoCL cables.
- Note that these three connectors are identical on the two physical case sizes of the Nano-CL series.

The following figure of the Genie Nano-CL back end shows connector and LED locations. See [Mechanical Specifications — Nano-CL](#): for details on the connectors and camera mounting dimensions.

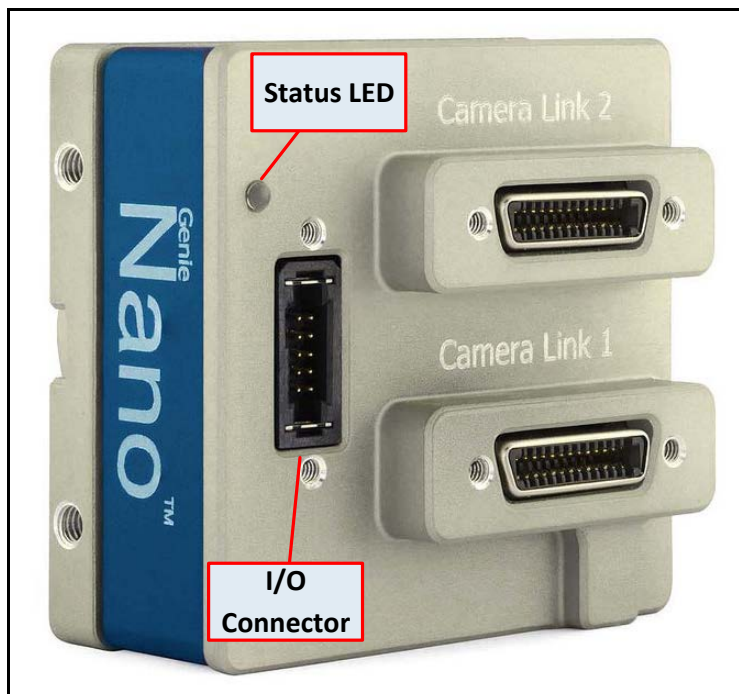

Genie Nano-CL (medium casing) – Rear View

LED Indicators

The Genie Nano-CL has one multicolor LED to provide a simple visible indication of camera state, as described below. The Nano-CL camera link connectors do not have any indicator LEDs but the frame grabber may have LEDs for data connection status.

Camera Status LED Indicator

The camera is equipped with one LED to display its operational status. When more than one condition is active, the LED color indicates the condition with the highest priority. The following table summarizes the LED states.

LED State	Definition
LED is off	No power to the camera
Steady Red	Initial state on power up before flashing. Remains as steady Red only if there is a fatal error.
Flashing Red	Initialization sequence in progress
Steady Red + Flashing Blue	Fatal Error. If the Genie Nano does not reboot itself contact Technical Support.
Fast Flashing Blue	File Access Feature is transferring data such as a firmware update, etc.
Steady Green	Ready to acquire images, such as waiting on an external trigger on CC1 for an example.
Flashing Green	Acquisition in progress. Flashing occurs on frame acquisition but does not exceed a rate of 100ms, irrelevant of faster frame rates.

LED States on Power Up

The following LED sequence occurs when the Genie Nano-CL is powered up connected to a frame grabber. Initialization is followed by one of three normal operational states.

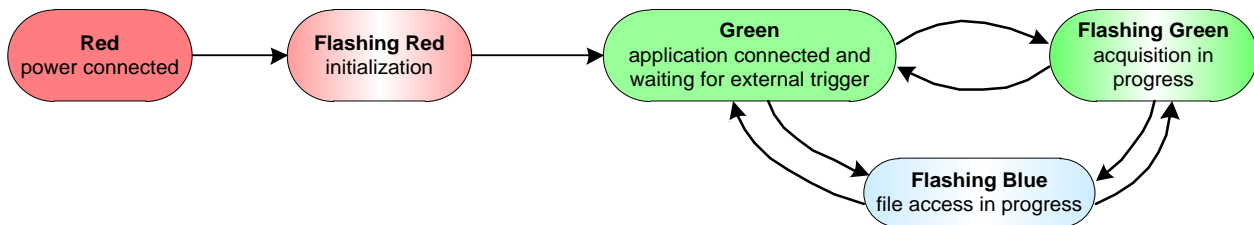

Preventing Operational Faults due to ESD

	<p>Nano camera installations which do not protect against ESD (electrostatic discharge) may exhibit operational faults. Problems such as random packet loss, random camera resets, and random loss of Ethernet connections, may all be solved by proper ESD management.</p>
---	---

Teledyne DALSA has performed ESD testing on Nano cameras using an 8 kilovolt ESD generator without any indication of operational faults. The two following methods, either individually or together will prevent ESD problems.

- Method 1: Use a shielded/grounded power supply that connects ground to pin-10 of the I/O connector. The Nano case is now properly connected to earth ground and can withstand ESD of 8 kilovolts, as tested by Teledyne DALSA.
- Method 2: Mount the camera on a metallic platform with a good connection to earth ground.

Operational Reference

Using CamExpert with Genie Nano Cameras

The Spera CamExpert tool is the interfacing tool for Teledyne DALSA Camera Link cameras and Frame grabbers. CamExpert allows a user to test camera and frame grabber combination and their functions. Additionally CamExpert saves the Teledyne DALSA frame grabber user settings as individual camera parameter files on the host system (*.ccf). The camera settings are saved within the camera as a user set.

An important component of CamExpert is its live acquisition display window which allows immediate verification of timing or control parameters without the need to run a separate acquisition program.



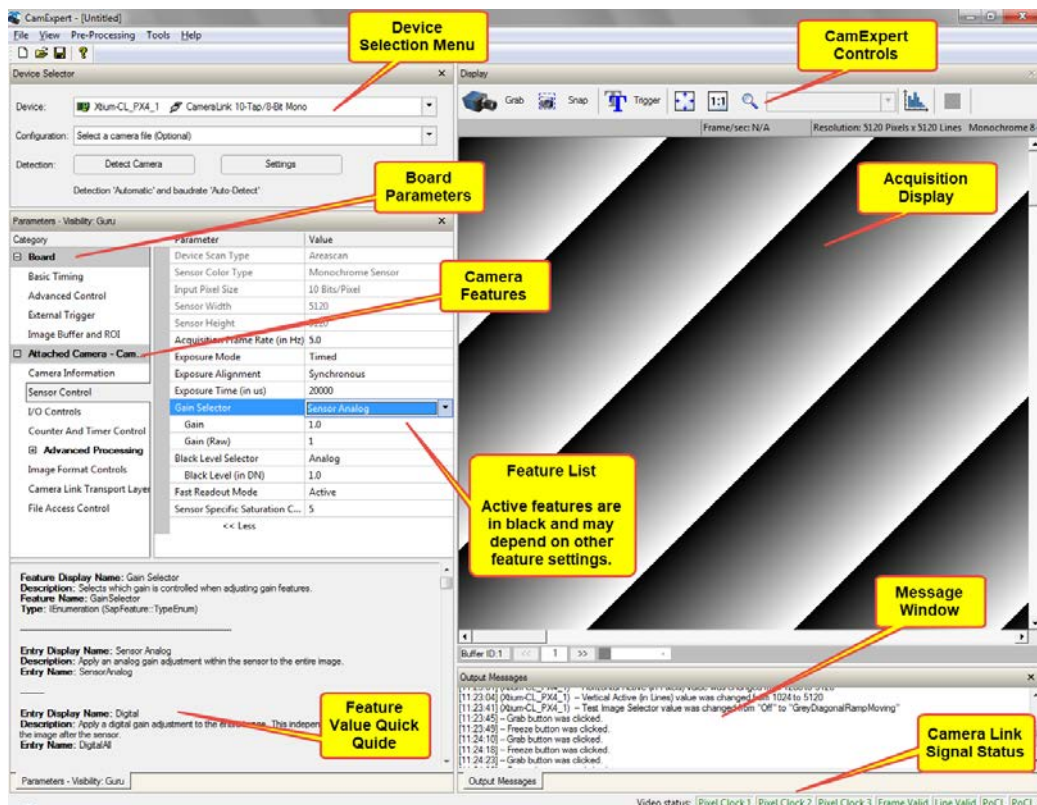

CamExpert Panes

The various areas of the CamExpert tool are described in the summary figure below. The following screen image shows camera and board device Categories and Parameter feature groups.

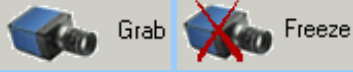

- **Device pane:** View and select from any installed Spera acquisition device, if more than one is installed in the computer. After a device is selected CamExpert will only present parameters applicable to that device.

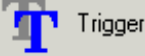
- Parameters pane:** Allows viewing or changing all acquisition parameters supported by the acquisition device. CamExpert displays parameters only if those parameters are supported by the installed device. This avoids confusion by eliminating parameter choices when they do not apply to the hardware in use.
 When using a Teledyne DALSA frame grabber and camera link camera, CamExpert groups all frame grabber parameters first and then follows with the supported camera features. Together the user configures the imaging system.
- Display pane:** Provides a live or single frame acquisition display. Frame buffer parameters are shown in an information bar above the image window.
- Control Buttons:** The Display pane includes CamExpert control buttons. These are:

	Acquisition control button: Click once to start the frame grabber live grab mode, click again to stop. The Nano-CL is always in free running acquisition mode unless configured to use an external trigger.
	Single frame grab: Click to acquire one frame from the frame grabber device.
	Software trigger button: With the I/O control parameters set to Trigger Enabled / Software Trigger type, click to send a single software trigger command.
	CamExpert display controls: (these do not modify the frame buffer data) Stretch (or shrink) image to fit, set image display to original size, or zoom the image to any size and ratio. Note that under certain combinations of image resolution, acquisition frame rate, and host computer speed, the CamExpert screen display may not update completely due to the host CPU running at near 100%. This does not affect the acquisition.
	Histogram / Profile tool: Select to view a histogram or line/column profile during live acquisition.

- Output pane:** Displays messages from CamExpert or the GigE Vision driver.
- Camera Link Signals:** Displays the status of various Camera Link timing signals plus active PoCL connections.

CamExpert View Parameters Option

While the **Board** section shows all frame grabber parameters, the **Attached Camera** section shows camera features filtered by a Visibility attribute which defines its requirement or complexity. The states vary from Beginner (features required for basic operation of the device) to Guru (optional features required only for complex operations).

CamExpert presents camera features based on their visibility attribute and provides quick Visibility level selection via controls below each Category Parameter list [<< Less More >>]. The user can also choose the Visibility level from the *View · Parameters Options* menu.

About the Device User ID

The Nano-CL can be programmed with a user defined name to aid identifying multiple cameras connected to the network. For instance, on an inspection system with 4 cameras, the first camera might be labeled “top view”, the second “left view”, the third “right view” and the last one “bottom view”. The factory default user name is the camera serial number for quick initial identification.

Camera Information Category

Camera information can be retrieved via a controlling application. Parameters such as camera model, firmware version, etc. are read to uniquely identify the connected Nano-CL device. These features are typically read-only.

Features listed in the description table but tagged as *Invisible* are usually for Teledyne DALSA or third party software usage—not typically needed by end user applications.

Category	Parameter	Value
Board	Manufacturer Name	Teledyne DALSA
Basic Timing	Device Family	Genie
Advanced Control	Model Name	NanoCL-M5100
External Trigger	Device Version	1.00
Image Buffer and ROI	Manufacturer Part Number	G3-CM10-M510550
Attached Camera - CameraLink_1	Manufacturer Info	80-bit 10 Taps Design
Camera Information	Firmware Version	1CA21.0010
Sensor Control	Serial Number	
I/O Controls	Device User ID	USCSS Nostromo
Counter And Timer Control	Device Built-In Self Test	Press...
Advanced Processing	Device Built-In Self Test Status	Passed
Image Format Controls	Device Built-In Self Test Status All	0
Camera Link Transport Layer	Device Reset	Press...
File Access Control	Device Temperature Selector	Internal
	Device Temperature	37.585945
	Power-up Configuration	Setting...
	<< Less	

Camera Information Feature Descriptions

The following table describes these parameters along with their view attribute and in which device version the feature was introduced. Additionally the Device Version column will indicate which parameter is a member of the DALSA Features Naming Convention (indicated by **DFNC**), versus the GenICam Standard Features Naming Convention (SFNC tag is not shown).

New features for a major device version release following release 1.00 will be indicated by **green text** for easy identification.

Display Name	Feature & Values	Description	Device Version & View
Manufacturer Name	DeviceVendorName	Displays the device vendor name.	1.00 Beginner
Device Family	DeviceFamilyName	Displays the device family name.	1.00 Beginner
Model Name	DeviceModelName	Displays the device model name.	1.00 Beginner
Device Version	DeviceVersion	Displays the device version. This tag will also highlight if the firmware is a beta or custom design.	1.00 Beginner
Manufacturer Part Number	deviceManufacturerPartNumber	Displays the device manufacturer part number.	1.00 DFNC Beginner
Manufacturer Info	DeviceManufacturerInfo	This feature provides extended manufacturer information about the device. Genie Nano cameras show which firmware design is currently loaded.	1.00 Beginner
Firmware Version	DeviceFirmwareVersion	Displays the currently loaded firmware version number. Firmware files have a unique number and have the .cbf file extension.	1.00 Beginner
Serial Number	DeviceSerialNumber	Displays the device's factory set serial number.	1.00 Expert
MAC Address	deviceMacAddress	Displays the unique MAC (Media Access Control) address of the Device.	1.00 DFNC Beginner
Device User ID	DeviceUserID	Feature to store a user-programmable identifier of up to 63 characters. The default factory setting is the camera serial number. (RW)	1.00 Beginner
Device Built-In Self Test	deviceBIST	Command to perform an internal test which will determine the device status. (W)	1.00 Beginner
Device Built-In Self Test Status	deviceBISTStatus	Return the status of the device Built-In Self-Test. Possible return values are device-specific.	1.00 Beginner
<i>Passed</i>	<i>Passed</i>	<i>No failure detected</i>	
<i>Last firmware update failed</i>	<i>FirmwareUpdateFailure</i>	<i>Last firmware update operation failed.</i>	
<i>Unexpected Error</i>	<i>Unexpected_Error</i>	<i>Switched to recovery mode due to unexpected software error.</i>	
<i>Sensor Initialization Failure</i>	<i>SensorFailure</i>	<i>There was an error initializing the sensor. The camera may not be able to capture images.</i>	
Device Built-In Self Test Status All	deviceBISTStatusAll	Return the status of the device Built-In Self-Test as a bitfield. The meaning for each bit is device-specific. A value of 0 indicates no error.	1.00 DFNC Beginner
Device Reset	DeviceReset	Resets the device to its power up state. (W)	1.00 Beginner
Device Temperature Selector	DeviceTemperatureSelector	Select the source where the temperature is read.	1.00 Beginner
<i>Internal</i>	<i>Internal</i>	<i>Value from FPGA and or PHY temperature.</i>	
<i>MaxInternal</i>	<i>MaxInternal</i>	<i>Records the highest device temperature since power up. Value is reset on power off.</i>	
Device Temperature	DeviceTemperature	The temperature of the selected source in degrees Celsius. Maximum temperature should not exceed +70°C for reliable operation.	1.00 Beginner

<u>Power-up Configuration Selector</u>	UserSetDefaultSelector	Selects the camera configuration set to load and make active on camera power-up or reset. The camera configuration sets are stored in camera non-volatile memory. (RW)	1.00 Beginner
<i>Factory Setting</i>	<i>Default</i>	Select the default camera feature settings saved by the Factory.	
<i>UserSet1</i>	<i>UserSet1</i>	Select the User defined Configuration space UserSet1 to save to or load from features settings previously saved by the user.	
<i>UserSet2</i>	<i>UserSet2</i>	Select the User defined Configuration space UserSet2 to save to or load from features settings previously saved by the user.	
<u>User Set Selector</u>	UserSetSelector	Selects the camera configuration set to load feature settings from or save current feature settings to. The Factory set contains default camera feature settings. (RW)	1.00 Beginner
<i>Factory Setting</i>	<i>Default</i>	Select the default camera feature settings saved by the factory.	
<i>UserSet 1</i>	<i>UserSet1</i>	Select the User Defined Configuration space UserSet1 to save to or load from features settings previously saved by the user.	
<i>UserSet 2</i>	<i>UserSet2</i>	Select the User Defined Configuration space UserSet1 to save to or load from features settings previously saved by the user.	
Load Configuration	UserSetLoad	Loads the camera configuration set specified by the User Set Selector feature, to the camera and makes it active. Cannot be updated during a Samera transfer. (W)	1.00 Beginner
Save Configuration	UserSetSave	Saves the current camera configuration to the user set specified by the User Set Selector feature. The user sets are located on the camera in non-volatile memory. (W)	1.00 Beginner
Power-up Configuration Selector	UserSetDefault	Specify the camera configuration set to load and make active on camera power-up or reset. The camera configuration sets are stored in camera non-volatile memory.	1.00 Beginner
Serial Number	DeviceID	Displays the device's factory set camera serial number.	1.00 Invisible
<i>Factory Setting</i>	<i>Default</i>	Select the Factory Setting values as the Power-up Configuration.	1.00 Invisible
<i>UserSet1</i>	<i>UserSet1</i>	Select the user defined configuration UserSet 1 as the Power-up Configuration.	
<i>UserSet2</i>	<i>UserSet2</i>	Select the user defined configuration UserSet 2 as the Power-up Configuration.	
Calibration Date	deviceCalibrationDateRaw	Date when the camera was calibrated.	
Device Acquisition Type	deviceAcquisitionType	Displays the Device Acquisition Type of the product.	1.00 DFNC Invisible
<i>Sensor</i>	<i>Sensor</i>	The device gets its data directly from a sensor.	
Device TL Type	DeviceTLType	Transport Layer type of the device.	1.00 DFNC Invisible
<i>Camera Link</i>	<i>CameraLink</i>	<i>Camera Link</i>	
Device TL Version Major	DeviceTLVersionMajor	Major version of the device's Transport Layer.	1.00 Invisible
Device TL Version Minor	DeviceTLVersionMinor	Minor version of the device's Transport Layer.	
	userSetError	Error Flags for UserSetLoad & UserSetSave	1.00 Invisible
	<i>NoError</i>	<i>No Error</i>	
	<i>LoadGenericError</i>	<i>Unknown error</i>	

	<i>LoadBusyError</i>	<i>The camera is busy and cannot perform the action</i>	
	<i>LoadMemoryError</i>	<i>Not enough memory to load set</i>	
	<i>LoadFileError</i>	<i>Internal file I/O error</i>	
	<i>LoadInvalidSetError</i>	<i>At least one register could not be restored properly</i>	
	<i>LoadResourceManagerError</i>	<i>An internal error happened related to the resource manager</i>	
	<i>SaveGenericError</i>	<i>Unknown error</i>	
	<i>SaveBusyError</i>	<i>The camera is busy and cannot perform the action</i>	
	<i>SaveMemoryError</i>	<i>Camera ran out of memory while saving set</i>	
	<i>SaveFileError</i>	<i>Internal file I/O error</i>	
	<i>SaveInvalidSetError</i>	<i>An invalid user set was requested</i>	
	<i>SaveResourceManagerError</i>	<i>An internal error happened related to the resource manager</i>	
DFNC Major Rev	deviceDFNCVersionMajor	Major revision of Dalsa Feature Naming Convention which was used to create the device's XML.	1.00 DFNC Invisible
DFNC Minor Rev	deviceDFNCVersionMinor	Minor revision of Dalsa Feature Naming Convention which was used to create the device's XML.	1.00 DFNC Invisible
SFNC Major Rev	DeviceSFNCVersionMajor	Major Version of the Genicam Standard Features Naming Convention which was used to create the device's XML.	1.00 DFNC Invisible
SFNC Minor Rev	DeviceSFNCVersionMinor	Minor Version of the Genicam Standard Features Naming Convention which was used to create the device's XML.	1.00 DFNC Invisible
SFNC SubMinor Rev	DeviceSFNCVersionSubMinor	SubMinor Version of the Genicam Standard Features Naming Convention which was used to create the device's XML.	1.00 Invisible

Power-up Configuration Dialog

CamExpert provides a dialog box which combines the features to select the camera power-up state and for the user to save or load a Nano camera state.

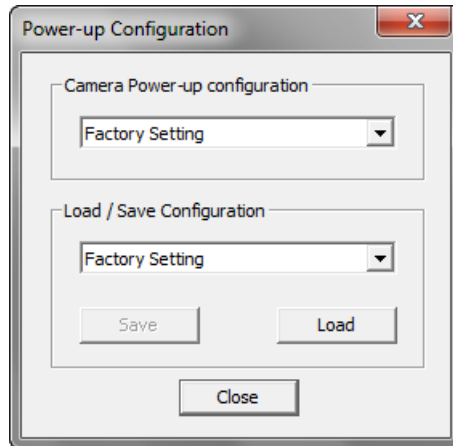

Camera Power-up Configuration

The first drop list selects the camera configuration state to load on power-up (see feature *UserSetDefaultSelector*). The user chooses from one factory data set or one of two possible user saved states.

Load / Save Configuration

The second drop list allows the user to change the camera configuration any time after a power-up (see feature *UserSetSelector*). To reset the camera to the factory configuration, select *Factory Setting* and click Load. To save a current camera configuration, select User Set 1 or 2 and click Save. Select a saved user set and click Load to restore a saved configuration.

Sensor Control Category

The Genie Nano-CL sensor controls, as shown by CamExpert, groups sensor specific parameters. This group includes controls for frame rate, exposure time, gain, etc. Parameters in gray are read only, either always or due to other feature settings. Parameters in black are user set in CamExpert or programmable via an imaging application.

Features listed in the description table that are tagged as *Invisible* are usually for Teledyne DALSA or third party software usage—not typically needed by end user applications. Also important, features shown by CamExpert may change with different Genie Nano-CL models implementing different sensors, image resolutions and color versions.

Category	Parameter	Value
Board	Device Scan Type	Areascan
Basic Timing	Sensor Color Type	Monochrome Sensor
Advanced Control	Input Pixel Size	10 Bits/Pixel
External Trigger	Sensor Width	5120
Image Buffer and ROI	Sensor Height	5120
Attached Camera - CameraLink_1	Acquisition Frame Rate (in Hz)	5.0
Camera Information	Exposure Mode	Timed
Sensor Control	Exposure Alignment	Synchronous
I/O Controls	Exposure Time (in us)	20000
Counter And Timer Control	Gain Selector	Sensor Analog
Advanced Processing	Gain	1.0
Flat Field Correction	Gain (Raw)	1
Lens Shading Correction	Black Level Selector	Analog
Image Format Controls	Black Level (in DN)	1.0
Camera Link Transport Layer	Fast Readout Mode	Active
File Access Control	Sensor Specific Saturation Control	5
	<< Less	

Sensor Control Feature Descriptions

The following table describes these features along with their view attribute and device version. For each feature the device version may differ for each camera sensor available.

When a Device Version number is indicated, this represents the camera software functional group, not a firmware revision number. As Genie Nano capabilities evolve the device version will increase, therefore identifying the supported function package. New features for a major device version release will be indicated by **green text** for easy identification.

The first column indicates whether a feature applies to monochrome or color camera models via a symbol. No symbol indicates a common feature. Additionally the description column will indicate which feature is a member of the DALSA Features Naming Convention (indicated by DFNC), versus the GenICam Standard Features Naming Convention (SFNC tag is not shown).

Display Name	Feature & Values	Description	Device Version & View
Device Scan Type	DeviceScanType	Defines the scan type of the device's sensor. Genie Nano-CL is an Areascan camera.	1.00 Beginner
<i>Areascan</i>	<i>Areascan</i>	<i>Device uses an Areascan sensor.</i>	
Sensor Color Type	sensorColorType	Defines the camera sensor color type.	1.00 DFNC Beginner
<i>Monochrome Sensor</i>	<i>Monochrome</i>	<i>Sensor color type is monochrome.</i>	
Bayer Sensor	<i>CFA_Bayer</i>	<i>Sensor color type is Bayer Color Filter Array (CFA).</i>	
Input Pixel Size	pixelSizeInput	Size of the image input pixels, in bits per pixel.	1.00 DFNC Guru
<i>8 Bits/Pixel</i>	<i>Bpp8</i>	<i>Sensor output data path is 8 bits per pixel.</i>	
<i>10 Bits/Pixel</i>	<i>Bpp10</i>	<i>Sensor output data path is 10 bits per pixel.</i>	
Sensor Width	SensorWidth	Defines the sensor width in active pixels.	1.00 Expert
Sensor Height	SensorHeight	Defines the sensor height in active lines.	1.00 Expert
Acquisition Frame Rate	AcquisitionFrameRate	Specifies the camera internal frame rate, in Hz. Any user entered value is automatically adjusted to a valid camera value. Note that a change in frame rate takes effect only when the acquisition is stopped and restarted.	1.00 Beginner
Exposure Mode	ExposureMode	Sets the operation mode for the camera's exposure (or electronic shutter).	1.00 Beginner
<i>Timed</i>	<i>Timed</i>	<i>The exposure duration time is set using the Exposure Time feature and the exposure starts with a FrameStart event.</i>	
<i>Trigger Width</i>	<i>TriggerWidth</i>	<i>Uses the width of the trigger signal pulse to control the exposure duration. Use the Trigger Activation feature to set the polarity of the trigger. The Trigger Width setting is applicable with Trigger Selector = Single Frame Trigger(Start). Note that the Line Inverter feature setting may affect the polarity of the trigger signal and is only available when exposureAlignment = Reset.</i>	
Exposure Alignment	exposureAlignment	Exposure Alignment specifies how the exposure is executed in relationship to the sensor capabilities and current frame trigger.	1.00 DFNC Beginner
<i>Synchronous</i>	<i>Synchronous</i>	<i>Exposure is synchronous to the internal timing of the sensor. The readout is concurrent to the exposure for the fastest possible frame rate. When a valid trigger is received and the ExposureTime is shorter than the readout period, the ExposureStart event is latched in the previous frame's readout. That is; the ExposureStartEvent is delayed and is initiated when the actual exposure starts such that the exposure ends and readout begins as soon as the previous readout has completed.</i>	
<i>Reset</i>	<i>Reset</i>	<i>Sensor timing is reset to initiate exposure when a valid trigger is received. Readout is sequential to exposure, reducing the maximum achievable frame rates. That is, a trigger received during exposure or readout is ignored since data would be lost by performing a reset.</i>	
Exposure Time	ExposureTime	Sets the exposure time (in microseconds) when the Exposure Mode feature is set to Timed.	1.00 Beginner

Gain Selector	GainSelector	Selects which gain is controlled when adjusting gain features.	1.00 Beginner
<i>Sensor</i>	<i>SensorAll</i>	<i>Apply a gain adjustment within the sensor to the entire image. The first half of the gain range is applied in the analog domain and the second half is digital.</i>	
<i>Sensor Analog</i>	<i>SensorAnalog</i>	<i>Apply an analog gain adjustment within the sensor to the entire image.</i>	
<i>Sensor Digital</i>	<i>SensorDigital</i>	<i>Apply a digital gain adjustment within the sensor to the entire image.</i>	
<i>Digital</i>	<i>DigitalAll</i>	<i>Apply a digital gain adjustment to the entire image. This independent gain factor is applied to the image after the sensor.</i>	
Gain	Gain	Sets the selected gain as an amplification factor applied to the image. User adjusts the <i>Gain</i> feature or the <i>GainRaw</i> feature.	1.00 Beginner
Gain (Raw)	GainRaw	Raw Gain value that is set in camera (Model Specific for range and step values).	1.00 Guru
Black Level Selector	BlackLevelSelector	Selects which Black Level to adjust using the Black Level features.	1.00 Beginner
<i>Analog</i>	<i>AnalogAll</i>	<i>Sensor Dark Offset</i>	
Black Level	BlackLevel	Controls the black level as an absolute physical value. This represents a DC offset applied to the video signal, in DN (digital number) units. The Black Level Selector feature specifies the channel to adjust.	1.00 Beginner
Fast Readout Mode	fastReadoutMode	Selects the sensor's readout mode.	1.00 DFNC Guru
<i>Off</i>	<i>Off</i>	<i>When this mode is off, the row blanking and row readout occur sequentially in the sensor.</i>	
<i>Active</i>	<i>Active</i>	<i>When this mode is active, the row blanking and row readout occur in parallel in the sensor. This helps achieve a lower total frame readout time resulting in a faster maximum frame rate. There are minor DN column artifacts, typically of no significance.</i>	
Sensor Specific Saturation Control	sensorSpecificSaturationControl	Specific for this sensor. Increasing this value can remove the black sun effect (over-saturated pixels that revert to black data) when the strobe lighting extends longer than the exposure period.	1.00 DFNC Guru
Black Level Raw	BlackLevelRaw	Controls the black level as an absolute physical value.	1.00 Invisible

Offset/Gain Control Details (On-Semi Python sensors)

The Gain and Black level functions are applied at the sensor and/or on the digital image values output by the sensor, as described below.

- **Gain Selector = Sensor Analog:** The gain function is a linear multiplier control in 0.01 steps within the sensor hardware.
- **Gain Selector = Sensor Digital:** The gain function is a linear multiplier control in 0.1 steps within the sensor hardware.
- **Important:** Digital noise increases linearly and quickly with higher gain values. Users should evaluate image quality with added gain.
- **Gain (Raw):** Shows the raw sensor control for each gain stage or an alternative method to control sensor gain.
- **Black Level:** This offset variable exists within the sensor. The On-Semi sensors allow an offset range between 0 and 255 DN. The factory settings default value for each sensor used by various Nano models, is recommended as per the sensor manufacturer design specifications.

Note: With the factory default offset, testing a camera's black output in 8-bit mode may show a 2 DN value difference across the image. Changing the Black Level value up or down will push sensor noise (present at the sensors native bits per pixel) to fall within one 8-bit value, thus the noise becomes hidden.

On-Semi Python Sensors Gain Stage Diagram

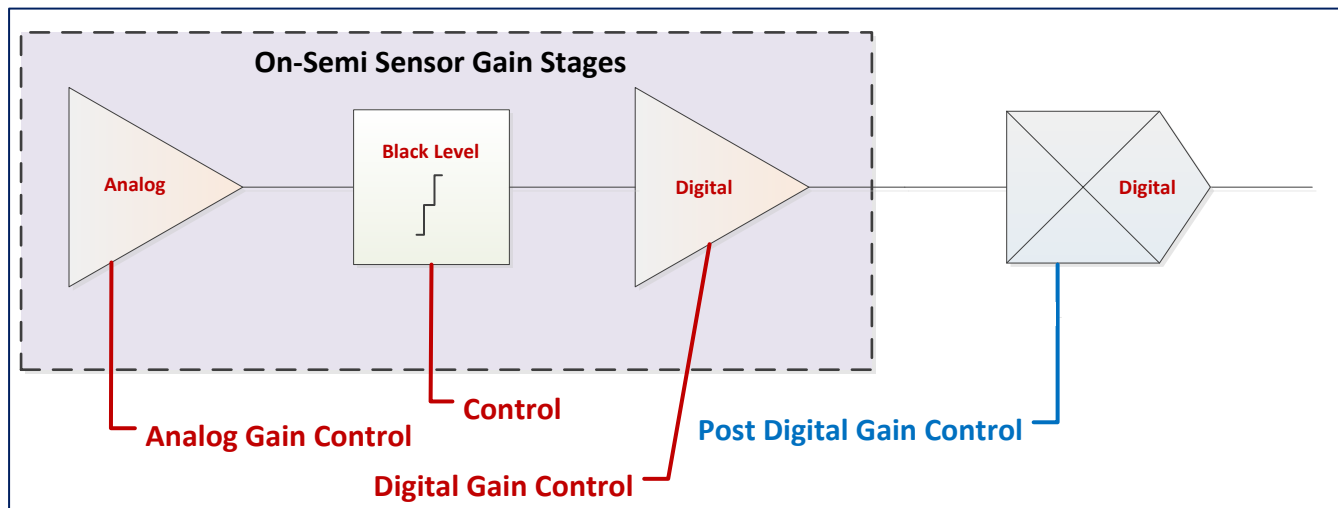

OnSemi Sensor Artifacts with Fast Readout Mode

Applicable only when Flat Field Correction is purposely disabled.

When Fast Readout mode is active (cameras with OnSemi sensors), the row blanking and row readout occurs in parallel in the sensor. This reduces the total frame readout time resulting in a faster maximum frame rate. As a consequence of this mode there are minor column artifacts (of very low DN), typically of no significance and irrelevant for many imaging systems. Note that these column artifacts will become more prominent as sensor gain is increased.

The image below shows a “dark” capture with Fast Readout Mode enabled and analog gain set to maximum. The artifacts will become visible as fixed pattern DN column variations near the left edge of the video frame. There are darker columns followed by lighter columns as marked by the overlay graphics. These DN variations are not random columns, but consistent between individual OnSemi sensors operating in Fast Readout mode with high gain.

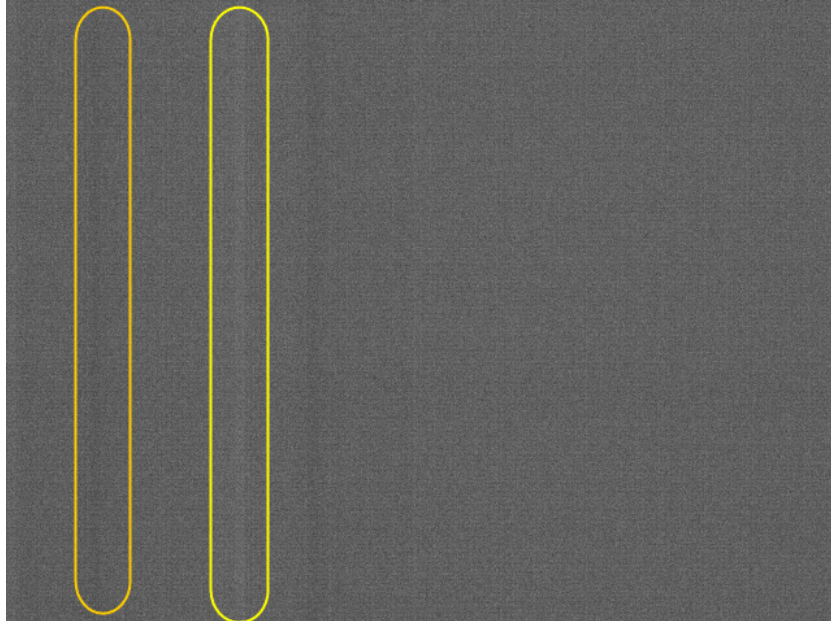

Fast Readout Mode Artifacts Correction

As noted in this section, the Fast Readout mode artifacts are automatically corrected by the factory default enabled Flat Field correction.

Alternatively for **maximum acquisition quality**, disable Fast Readout Mode to eliminate acquisition DN variances, at a small reduction of the maximum frame rate. Also remember that high gain settings will increase overall sensor noise therefore additional gain should be used only when necessary.

Exposure Alignment: Overview

Exposure Control modes define the method and timing of controlling the sensor integration period. The integration period is the amount of time the sensor is exposed to incoming light before the video frame data is transmitted to the controlling computer.

- Exposure control is defined as the start of exposure and exposure duration.
- The feature **Exposure Mode** selects the controlling method for the exposure.
- The start of exposure is initiated by an internal timer signal, an external input trigger signal (Trigger Mode=ON), or a software function call.
- The exposure duration can be programmable (Exposure Mode = Timed, *free run or external trigger*) or controlled by the external input trigger pulse width (Exposure Mode = TriggerWidth).

Note that different Nano models will support different combinations of exposure controls.

See also [Trigger Overlap: Feature Details](#).

Synchronous Exposure Alignment

Exposure is synchronous to the internal timing of the sensor. The readout is concurrent to the exposure for the fastest possible frame rate.

When a valid trigger is received and the Exposure Time is shorter than the readout period, the Exposure Start event is latched in the previous frame's readout. That is; the Exposure Start Event is delayed and is initiated when the actual exposure starts such that the exposure ends and readout begins as soon as the previous readout has completed.

- The programmable exposure duration is in 1 μ s steps.
- Exposure duration is from a camera sensor specific minimum (in μ s) up to 16 sec.
- Any trigger received before the start of frame readout is ignored and generates an invalid frame trigger event.

Reset Exposure Alignment

Sensor timing is reset to initiate exposure when a valid trigger is received. Readout is sequential to exposure, reducing the maximum achievable frame rates. That is, a trigger received during exposure or readout is ignored since data would be lost by performing a reset.

Sensor Exposure Timing: OnSemi Python Models

Nano cameras with OnSemi sensors have general timing characteristics as described below.

Trigger Characteristics: Start of Exposure

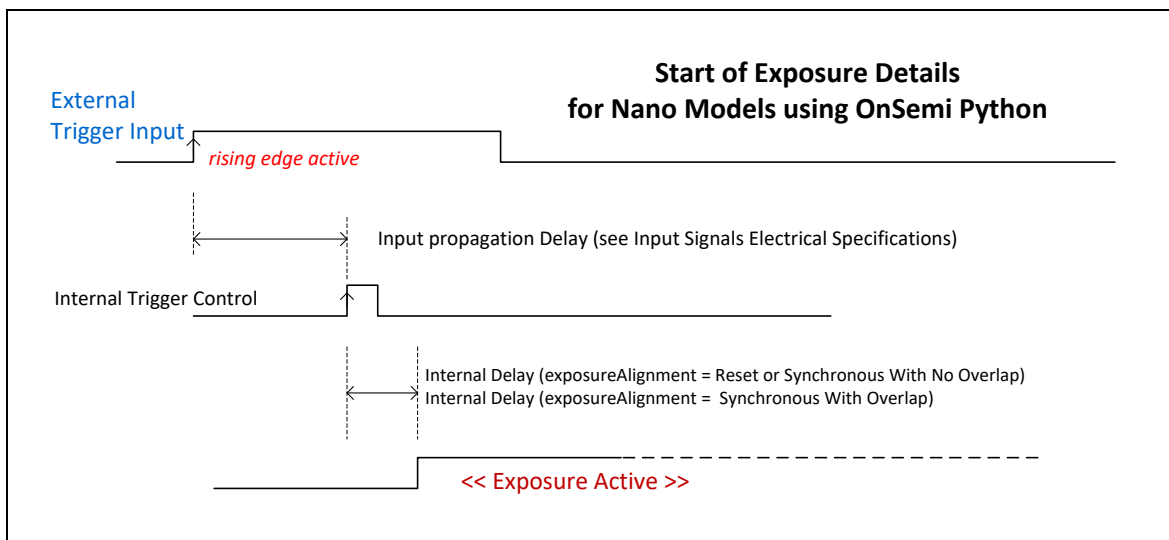

Additional triggered exposure mode features and timing specific to OnSemi sensors are described in the [I/O Controls Category](#).

See model specific sections for explicit timing values.

I/O Control Category

The Genie Nano I/O controls, as shown by CamExpert, groups' features used to configure acquisition actions based on those inputs. Parameters in gray are read only, either always or due to another parameter being disabled. Parameters in black are user set in CamExpert or programmable via an imaging application.

Features listed in the description table but tagged as *Invisible* are usually for Teledyne DALSA or third party software usage—not typically needed by end user applications. Also important, Genie Nano cameras are available in a number of models implementing different sensors which may support different features within this category.

Category	Parameter	Value
Board	Trigger Selector	Single Frame Trigger(Start)
Basic Timing	Trigger Mode	On
Advanced Control	Trigger Frames Count	Not Enabled
External Trigger	Software Trigger	Press...
Image Buffer and ROI	Trigger Source	CC1
Attached Camera - CameraLin...	Trigger Input Line Activation	Rising Edge
Camera Information	Trigger Overlap	Readout
Sensor Control	Trigger Delay (in us)	0.0
I/O Controls	Line Selector	CC1
Counter And Timer Control	Line Status	False
Advanced Processing	Line Inverter	False
Flat Field Correction	Input Line Debouncing Period	0
Lens Shading Correction	Line Status All	0x0000000000000000
Image Format Controls	<< Less	
Camera Link Transport Layer		
File Access Control		

I/O Control Feature Descriptions

The following table describes these features along with their view attribute and minimum camera firmware version required. Additionally the Device Version column will indicate which parameter is a member of the DALSA Features Naming Convention (indicated by DFNC), versus the GenICam Standard Features Naming Convention (SFNC tag is not shown).

The Device Version number represents the camera software functional group, not a firmware revision number. As Genie Nano capabilities evolve the device version tag will increase, therefore identifying the supported function package. New features for a major device version release will be indicated by **green text** for easy identification.

Display Name	Feature & Values	Description	Device Version & View
Trigger Selector	TriggerSelector	Selects which type of trigger to configure with the various Trigger features.	1.00 Beginner
<i>Single Frame Trigger(Start)</i>	<i>FrameStart</i>	<i>Selects a trigger starting the capture of a single frame. Frame size is determined by image format feature "Height".</i>	
<i>MultiFrame Trigger(Start)</i>	<i>FrameBurstStart</i>	<i>Selects a trigger to capture multiple frames. The number of frames is specified by the "triggerFrameCount" feature.</i>	
Trigger Mode	TriggerMode	Controls the enable state of the selected trigger.	1.00 Beginner
<i>Off</i>	<i>Off</i>	<i>The selected trigger is turned off.</i>	
<i>On</i>	<i>On</i>	<i>The selected trigger is turned active.</i>	
Trigger Frames Count	triggerFrameCount	Sets the total number of frames to acquire when a valid trigger is received. This feature is available when Trigger Selector = MultiFrame Trigger(Start).	1.00 DFNC Beginner
Software Trigger	TriggerSoftware	Generate a software command internal trigger immediately no matter what the TriggerSource feature is set to.	1.00 Beginner
Trigger Source	TriggerSource	Specifies the internal signal or physical input line to use as the trigger source. The selected trigger must have its TriggerMode set to ON.	1.00 Beginner
<i>CC1</i>	<i>CC1</i>	<i>Select CC1 (and associated I/O control block) to use as the external trigger source. See LineSelector feature for complete list.</i>	
<i>Software</i>	<i>Software</i>	<i>The trigger command source is only generated by software using the Trigger Software command.</i>	
<i>Timer1End Event</i>	<i>Timer1End</i>	<i>Select the TimerEnd Event as the internal trigger source.</i>	
<i>Counter1End Event</i>	<i>Counter1End</i>	<i>Select the CounterEnd Event as the internal trigger source.</i>	
Trigger Input Line Activation	TriggerActivation	Select the activation mode for the selected Input Line trigger source. This is applicable only for external line inputs.	1.00 Beginner
<i>Rising Edge</i>	<i>RisingEdge</i>	<i>The trigger is considered valid on the rising edge of the line source signal (after any processing by the line inverter module).</i>	
<i>Falling Edge</i>	<i>FallingEdge</i>	<i>The trigger is considered valid on the falling edge of the line source signal (after any processing by the line inverter module).</i>	
<i>Any Edge</i>	<i>AnyEdge</i>	<i>The trigger is considered valid on any edge of the line source signal (after any processing by the line inverter module).</i>	
<i>Level High</i>	<i>LevelHigh</i>	<i>The trigger is considered valid on the high level of the line source signal.</i>	

<i>Level Low</i>	<i>LevelLow</i>	<i>The trigger is considered valid on the low level of the line source signal.</i>	
Trigger Delay	TriggerDelay	Specifies the delay in microseconds to apply after receiving the trigger and before activating the triggerEvent. (min=0, max=2000000)	1.00 Beginner
Trigger Overlap	TriggerOverlap	States if a trigger overlap is permitted with the Active Frame readout signal. This feature defines if a new valid trigger will be accepted (or latched) for a new frame.	1.00 Guru
<i>Off</i>	<i>Off</i>	<i>No trigger overlap is permitted.</i>	
<i>ReadOut</i>	<i>ReadOut</i>	<i>Trigger is accepted immediately after the start of the readout.</i>	
<i>End Of Exposure</i>	<i>EndOfExposure</i>	<i>Trigger is accepted immediately after the previous exposure period. This will latch the Trigger and delay the Exposure if the end of that exposure is shorter than the previous readout.</i>	
Line Selector	LineSelector	Selects the physical line (or pin) of the external device connector to configure.	1.00 Beginner
<i>CC1</i>	<i>CC1</i>	<i>Select the Camera Link CC1.</i>	
<i>CC2</i>	<i>CC2</i>	<i>Select the Camera Link CC2.</i>	
Line Name	lineName	Description of the physical Pin associated with the logical line.	1.00 Beginner DFNC
<i>Camera Control 1</i>	<i>CC1</i>	<i>Camera Control 1 of the Camera Link connector</i>	
<i>Camera Control 2</i>	<i>CC2</i>	<i>Camera Control 2 of the Camera Link connector</i>	
Line Format	LineFormat	Specify the current electrical format of the selected physical input or output.	1.00 Expert
<i>LVDS</i>	<i>LVDS</i>	<i>The line accepts LVDS level signals.</i>	
<i>Opto-Coupled</i>	<i>OptoCoupled</i>	<i>The line is opto-Coupled.</i>	
Line Status	LineStatus	Returns the current status of the selected input or output line.	1.00 Expert
	<i>False</i>	<i>The Line is logic LOW</i>	
	<i>True</i>	<i>The Line is logic HIGH</i>	
Line Status All	LineStatusAll	Returns the current status of all available line signals, at time of polling, in a single bitfield. The order is Line1, Line2, Line3, ...	1.00 Expert
Line Inverter	LineInverter	Control to invert the polarity of the selected input or output line signal.	1.00 Beginner
	<i>False / True</i>		
Input Line Debouncing Period	lineDebouncingPeriod	Specifies the minimum delay before an input line voltage transition is recognizing as a signal transition.	1.00 Beginner DFNC
Line Mode	LineMode	Reports if the physical Line is an Input or Output signal..	1.00 Invisible
<i>Input</i>	<i>Input</i>	<i>The line is an input line.</i>	
<i>Output</i>	<i>Output</i>	<i>The line is an output line.</i>	
Input Line Detection Level	lineDetectionLevel	Specifies the voltage threshold required to recognize a signal transition on an input line.	1.00 Invisible DFNC
<i>Threshold for TTL</i>	<i>Threshold_for_TTL</i>	<i>A signal below 0.8V will be detected as a Logical LOW and a signal greater than 2.4V will be detected as a Logical HIGH on the selected input line.</i>	
Burst Frame Count	AcquisitionBurstFrameCount	Sets the maximum number of frames to acquire when a valid trigger is received. This feature is used when the Trigger Selector is set to FrameBurstStart.	1.00 Invisible
Line Pinout	linePinAssociation	Enumeration of the physical line (or pin) on the device I/O connector. (RO)	1.00 Invisible

Pin5=Signal – Pin3=Gnd	Pin5Signal_Pin3Gnd	Pin 5 is the Input Signal and Pin 3 is the common input Ground on the I/O connector.
Pin7=Signal – Pin3=Gnd	Pin7Signal_Pin3Gnd	Pin 7 is the Input Signal and Pin 3 is the common input Ground on the I/O connector.
Pin6=Signal – Pin4=Pwr	Pin6Signal_Pin4Pwr	Pin 6 is the Output Signal and Pin 4 is the common output Power on the device connector.
Pin8=Signal – Pin4=Pwr	Pin8Signal_Pin4Pwr	Pin 8 is the Output2 Signal and Pin 4 is the common output Power on the device connector.

I/O Module Block Diagram

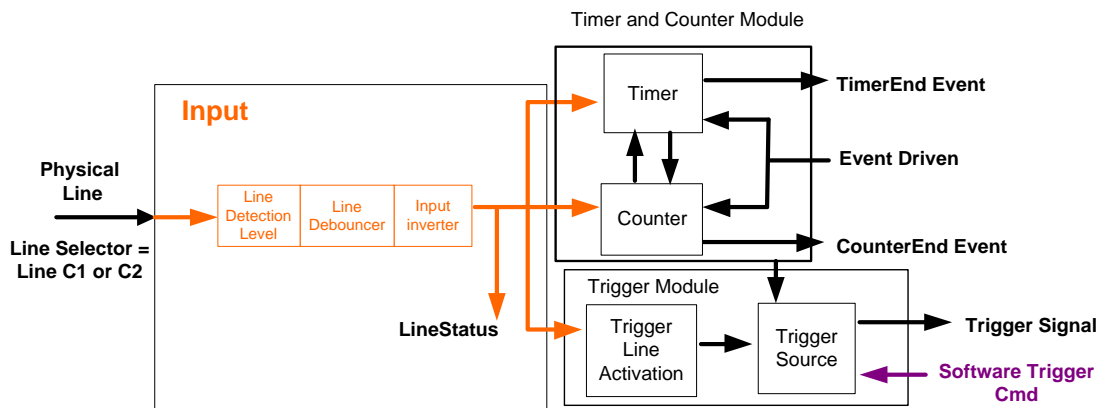

Trigger Mode Details

Nano-CL image exposures are initiated by an event. The trigger event is either the camera's programmable internal clock used in free running mode, an external input to the controlling frame grabber used for synchronizing exposures to external triggers, or a programmed function call message by the controlling computer. These triggering modes are described below.

- **Free running (Trigger Mode=Off):** The Nano free-running mode has programmable internal timers for frame rate and exposure period. Frame rate minimums, maximums, and increments supported are sensor specific. Maximum frame rates are dependent on the required exposure.
- **Trigger Source (Trigger Mode=On):** Exposures are controlled by an external trigger signal where the specific input line is selected by the **Trigger Source** feature.

Trigger Source Types (Trigger Mode=On)

- **Trigger Source=CC1:** The Camera Link CC1 line (controlled by the frame grabber) is used as the external trigger control.
- **Trigger Source=Software:** An exposure trigger is sent as a software command. Software triggers cannot be considered time accurate due to computer latency and sequential command jitter. But a software trigger is more responsive than calling a single-frame acquisition since the latter must validate the acquisition parameters and modify on-board buffer allocation if the buffer size has changed since the last acquisition.
- **Trigger Source=Timer1End Event:** The Timer1 End Event is used as the internal trigger source. Refer to [Counter and Timer Controls](#) for information on those features.
- **Trigger Source=Counter1End Event:** The Counter1 End Event is used as the internal trigger source.

Trigger Overlap: Feature Details

The Trigger Overlap feature defines how the Nano handles triggers that might occur more frequently than the Frame Active period (an exposure plus readout period).

If TriggerOverlap=OFF, then triggers received before the end of the Frame Active period are ignored. Other TriggerOverlap values are dependent on the Nano model and sensor used.

- **TriggerOverlap=Off**
- No trigger overlap is permitted.

Diagram Conditions:

- TriggerMode=On
- ExposureMode=Timed
- TriggerActivation=RisingEdge
- TriggerDelay=0
- TriggerSelector=FrameStart
- ExposureAlignment=Synchronous

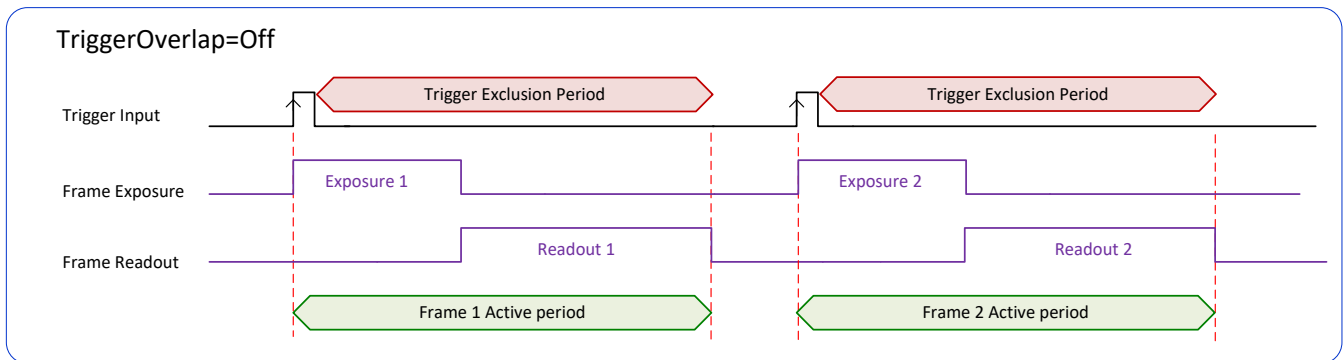

Timing specific to OnSemi models

- Minimum Trigger to Exposure start delay: $3.23\mu\text{s}$ (shown as $4\mu\text{s}$)
- Readout Time:
 - M/C 5100 & M/C 4090:
(Horizontal Line Time * NB Lines) + (2 * Horizontal Line Time at Maximum Sensor Width), in μs
see [Nano-CL Specifications: M5100, C5100, M4090, C4090](#)

- **TriggerOverlap=ReadOut**
- Trigger is accepted at the beginning of the frame Readout. The “End of Exposure to Start of Readout” time is sensor dependent.

Diagram Conditions:

- TriggerMode=On
- ExposureMode=Timed
- TriggerActivation=RisingEdge
- TriggerDelay=0
- TriggerSelector=FrameStart
- ExposureAlignment=Synchronous

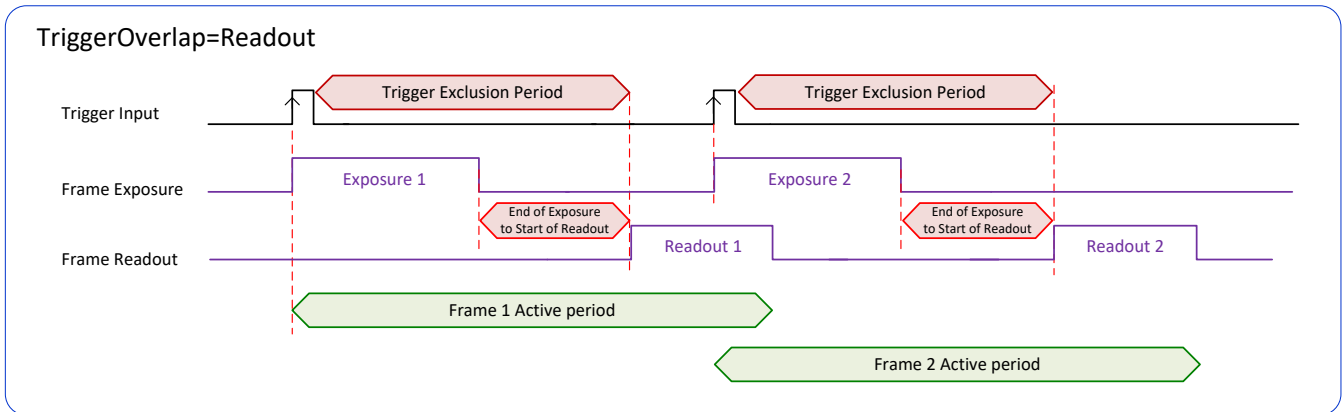

Timing specific to OnSemi models

- Trigger to Exposure start has a delay which includes the sensor readout time plus a minimum of 62µs. An exposure always starts after the readout of the previous frame.
- Trigger Delay Times (min. with normal ROT):
 - M/C 5100 & M/C 4090: see [Nano-CL Specifications: M5100, C5100, M4090, C4090](#)

- **TriggerOverlap= EndOfExposure or Readout**
- This special condition describes the case of a short exposure relative to the readout period. A trigger received before the end of the frame readout is latched and delayed until such time that the following short exposure will end with the end of the previous frame readout. The second readout period will then start immediately.

Diagram Conditions:

- TriggerMode=On
- ExposureMode=Timed
- TriggerActivation=RisingEdge
- TriggerDelay=0
- TriggerSelector=FrameStart
- ExposureAlignment=Synchronous

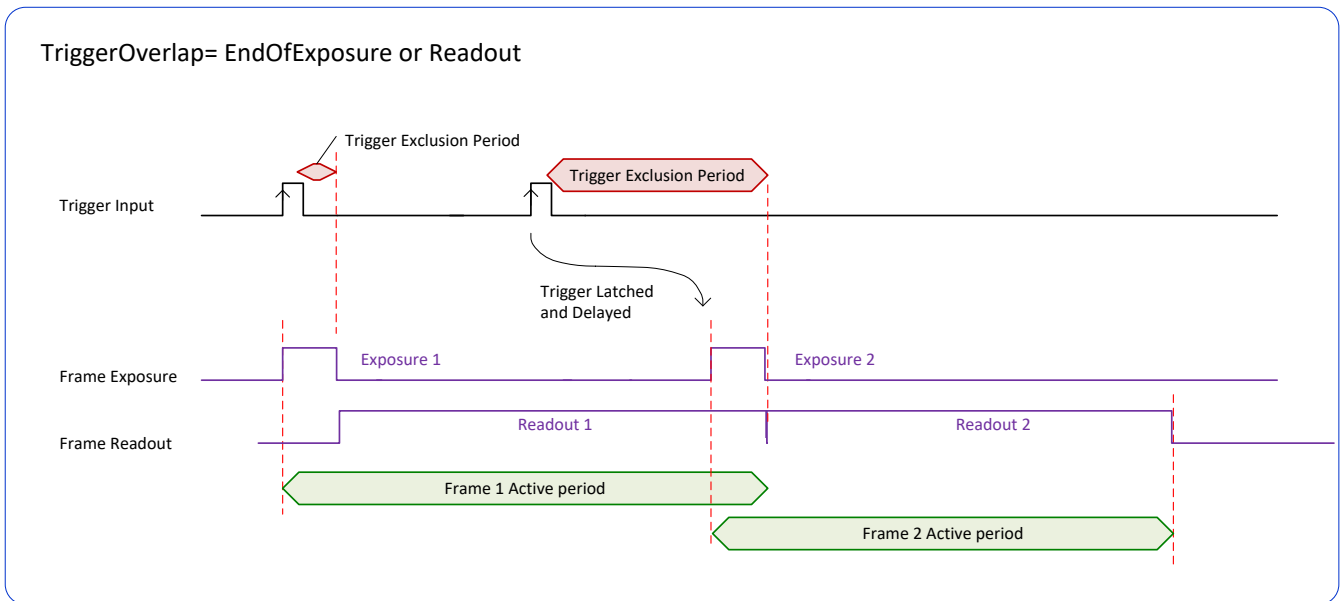

- **TriggerOverlap= Readout and ExposureMode=TriggerWidth**
- This special condition describes the case of a short TriggerWidth exposure relative to the readout period. If the next Trigger input signal occurs during the previous frame readout, attempting to stop the frame active period before the current readout is completed, the camera will continue the second exposure until the previous readout is completed. In this condition the actual exposure time is longer than the trigger input width.

Diagram Conditions (OnSemi Sensors):

- TriggerMode=On
- ExposureMode=TriggerWidth
- TriggerActivation=RisingEdge
- TriggerDelay=0
- TriggerSelector=FrameStart
- ExposureAlignment=Synchronous

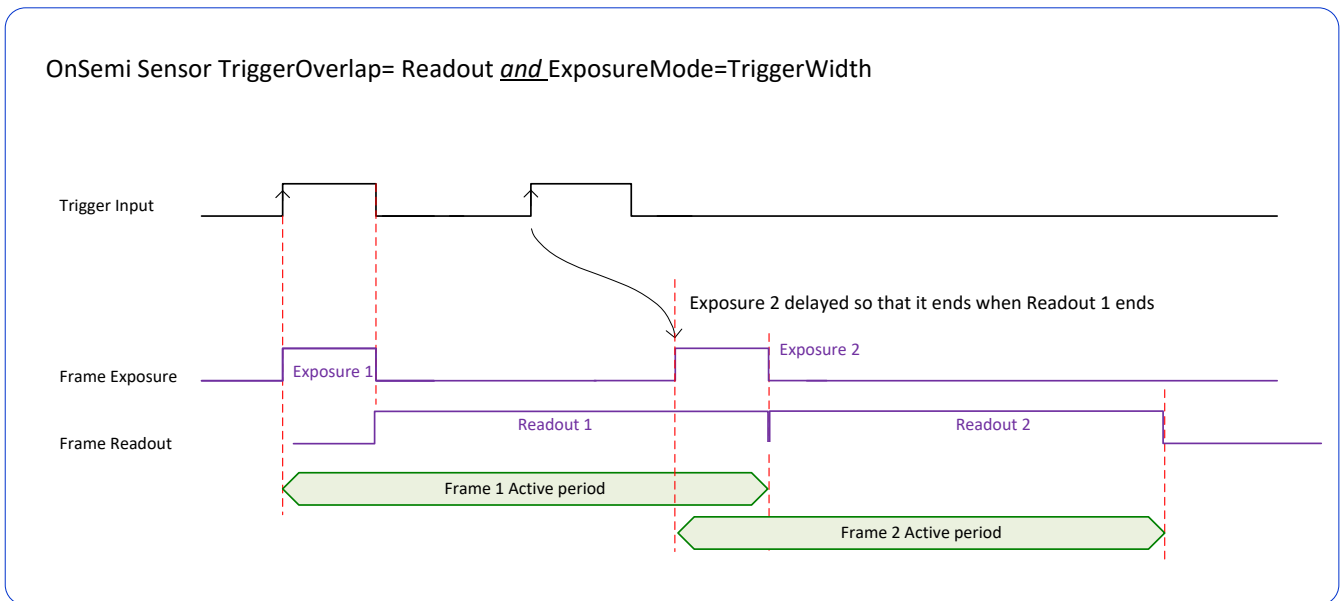

- **TriggerOverlap=Off and ExposureMode=TriggerWidth**

Diagram Conditions:

- TriggerMode=On
- ExposureMode=TriggerWidth
- TriggerActivation=RisingEdge
- TriggerDelay=0
- TriggerSelector=FrameStart
- ExposureAlignment=Synchronous

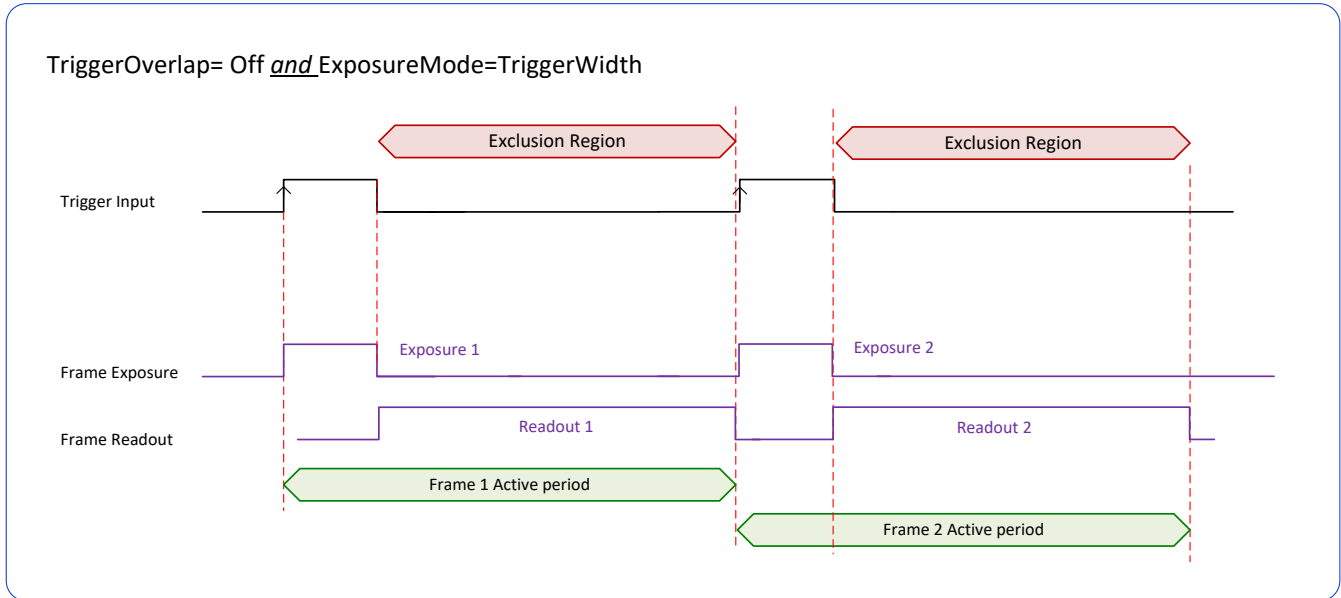

Counter and Timer Control Category

The Genie Nano-CL counter and timer controls, as shown by CamExpert, groups parameters used to configure acquisition counters and timers. Parameters in gray are read only, either always or due to another parameter being disabled. Parameters in black are user set in CamExpert or programmable via an imaging application.

Features listed in the description table but tagged as *Invisible* are usually for Teledyne DALSA or third party software usage—not typically needed by end user applications. Also important, Nano cameras are available in a number of models implementing different sensors and image resolutions which may not support the full feature set defined in this category.

Category	Parameter	Value
Board	Counter Selector	Counter 1
Basic Timing	Counter mode	Active
Advanced Control	Counter Status	Counter Trigger Wait
External Trigger	Counter Start Source	CC1
Image Buffer and ROI	Counter Start Line Activation	Rising Edge
Attached Camera - CameraLink_1	Counter Incremental Source	Exposure Start
Camera Information	Counter Incremental Line Activation	Not Enabled
Sensor Control	Counter Reset Source	Reset Cmd
I/O Controls	Counter Reset Input Line Activation	Not Enabled
Counter And Timer Control	Counter Duration	1
Advanced Processing	Counter Value	0
Flat Field Correction	Counter Value At Reset	0
Lens Shading Correction	Counter Reset	Press...
Image Format Controls	Timer Selector	Timer 1
Camera Link Transport Layer	Timer mode	Active
File Access Control	Timer Status	Timer Trigger Wait
	Timer Start Source	CC1
	Timer Line Activation	Rising Edge
	Timer Duration (in us)	1
	Timer Value	0
	Timer Reset	Press...
	<< Less	

Counter and Timer Control Feature Description

The following table and [block diagram](#), describes these parameters along with their view attribute and minimum camera firmware version required. Additionally the Device Version column will indicate which feature is a member of the DALSA Features Naming Convention (indicated by DFNC), versus the GenICam Standard Features Naming Convention (SFNC tag is not shown).

The Device Version number represents the camera software functional group, not a firmware revision number. As Nano-CL capabilities evolve the device version tag will increase, therefore identifying the supported function package. New features for a major device version release will be indicated by **green text** for easy identification.

Display Name	Feature & Values	Description	Device Version & View
Counter Selector	counterSelector	Selects the counter to configure.	1.00 Expert DFNC
<i>Counter 1</i>	<i>Counter1</i>	<i>Select counter 1</i>	
Counter mode	counterMode	Selects the counter mode. The selected Counter is either Active or Disabled. When Disabled, the Counter can be configured.	1.00 Expert DFNC
<i>Off</i>	<i>Off</i>	<i>The selected Counter is Disabled</i>	
<i>Active</i>	<i>Active</i>	<i>The selected Counter is Enabled</i>	
Counter Status	counterStatus	Returns the current state of the counter.	1.00 Expert DFNC
<i>Counter Idle</i>	<i>CounterIdle</i>	<i>The counter is idle. The counterStartSource feature is set to off.</i>	
<i>Counter Trigger Wait</i>	<i>CounterTriggerWait</i>	<i>The counter is waiting for a start trigger.</i>	
<i>Counter Active</i>	<i>CounterActive</i>	<i>The counter is counting for the specified duration.</i>	
<i>Counter Completed</i>	<i>CounterCompleted</i>	<i>The counter reached the CounterDuration count.</i>	
<i>Counter Overflow</i>	<i>CounterOverflow</i>	<i>The counter reached its maximum possible count.</i>	
Counter Start Source	counterStartSource	Select the counter start source. Counter increments from 0 to the value of the counterDuration feature.	1.00 Expert DFNC
<i>Off</i>	<i>Off</i>	<i>Counter is stopped.</i>	
<i>Exposure Start</i>	<i>ExposureStart</i>	<i>Counter starts on the reception of the Exposure Start event</i>	
<i>Exposure End</i>	<i>ExposureEnd</i>	<i>Counter starts on the reception of the Exposure End event.</i>	
<i>Readout Start</i>	<i>ReadoutStart</i>	<i>Counter starts on the reception of the Readout Start event.</i>	
<i>Readout End</i>	<i>ReadoutEnd</i>	<i>Counter starts on the reception of the Readout End event.</i>	
<i>Frame Start</i>	<i>FrameStart</i>	<i>Counter starts on the reception of the Frame Start event.</i>	
<i>Valid Frame Trigger</i>	<i>ValidFrameTrigger</i>	<i>Counter starts on the reception of the Valid Frame Trigger.</i>	
<i>Rejected Frame Trigger</i>	<i>InvalidFrameTrigger</i>	<i>Counter starts on the reception of the Invalid Frame Trigger.</i>	
<i>CC1</i>	<i>CC1</i>	<i>Counter starts on the specified transitions on CC1.</i>	
<i>Timer 1 End</i>	<i>Timer1End</i>	<i>Counter starts on the reception of the Timer 1 End event.</i>	
<i>Counter 1 End</i>	<i>Counter1End</i>	<i>Counter starts on the reception of the Counter 1 End event.</i>	
Counter Start Line Activation	counterStartLineActivation	Selects the activation mode of the input line trigger which starts the counter. This is only applicable when the counterStartSource feature selects a physical Line.	1.00 Expert DFNC

<i>Rising Edge</i>	<i>RisingEdge</i>	<i>Starts counting on rising edge of the selected Line.</i>	1.00 Expert DFNC
<i>Falling Edge</i>	<i>FallingEdge</i>	<i>Starts counting on falling edge of the selected Line.</i>	
<i>Any Edge</i>	<i>AnyEdge</i>	<i>Starts counting on the falling or rising edge of the selected Line.</i>	
Counter Incremental Source	counterIncrementalSource	Select the event source which increments the counter. The Event Control section provides details and timing diagrams for the supported events.	
<i>Off</i>	<i>Off</i>	<i>Counter is stopped.</i>	
<i>Exposure Start</i>	<i>ExposureStart</i>	<i>Counts the number of Exposure Start events.</i>	
<i>Exposure End</i>	<i>ExposureEnd</i>	<i>Counts the number of Exposure End events.</i>	
<i>Readout Start</i>	<i>ReadoutStart</i>	<i>Counts the number of Readout Start events.</i>	
<i>Readout End</i>	<i>ReadoutEnd</i>	<i>Counts the number of Readout End events.</i>	
<i>Frame Start</i>	<i>FrameStart</i>	<i>Counts the number of Frame Start events.</i>	
<i>Valid Frame Trigger</i>	<i>ValidFrameTrigger</i>	<i>Counts the number of Valid Frame Triggers.</i>	
<i>Rejected Frame(s) Trigger</i>	<i>InvalidFrameTrigger</i>	<i>Counts the number of Rejected Frame(s) Trigger.</i>	
<i>CC1</i>	<i>CC1</i>	<i>Counts the number of transitions on CC1 (based on the counterIncrementalLineActivation feature setting).</i>	
<i>Internal Clock</i>	<i>InternalClock</i>	<i>The counter increments on each microsecond tick of the device internal Clock.</i>	
<i>Timer 1 End</i>	<i>Timer1End</i>	<i>Counts the number of Timer 1 End events.</i>	
Counter Incremental Line Activation	counterIncrementalLineActivation	Selects the counter signal activation mode. The counter increments on the specified signal edge or level.	1.00 Expert DFNC
<i>Rising Edge</i>	<i>RisingEdge</i>	<i>Increment the counter on the rising edge of the selected I/O Line.</i>	
<i>Falling Edge</i>	<i>FallingEdge</i>	<i>Increment the counter on the falling edge of the selected I/O Line.</i>	
<i>Any Edge</i>	<i>AnyEdge</i>	<i>Increment the counter on the falling or rising edge of the selected I/O Line.</i>	
Counter Duration	counterDuration	Sets the duration (or number of events) before the CounterEnd event is generated.	1.00 Expert DFNC
Counter Reset Source	counterResetSource	Selects the signal source to reset the counter. After a reset the counter waits for the next countStartSource signal or event.	1.00 Expert DFNC
<i>Reset Cmd</i>	<i>Off</i>	<i>Reset on reception of the Reset Icommand.</i>	
<i>Exposure Start</i>	<i>ExposureStart</i>	<i>Reset on reception of the Exposure Start event.</i>	
<i>Exposure End</i>	<i>ExposureEnd</i>	<i>Reset on reception of the Exposure End event.</i>	
<i>Readout Start</i>	<i>ReadoutStart</i>	<i>Reset the counter on the reception of the Readout Start event.</i>	
<i>Readout End</i>	<i>ReadoutEnd</i>	<i>Reset the counter on the reception of the Readout End event.</i>	
<i>Frame Trigger</i>	<i>FrameStart</i>	<i>Reset on reception of the Frame Trigger.</i>	
<i>Valid Frame Trigger</i>	<i>ValidFrameTrigger</i>	<i>Reset on reception of the Valid Frame Trigger.</i>	
<i>Rejected Frame Trigger</i>	<i>InvalidFrameTrigger</i>	<i>Reset on reception of the Invalid Frame Trigger.</i>	
<i>CC1</i>	<i>CC1</i>	<i>Reset the Counter on the specified transitions on CC1.</i>	
<i>Timer 1 End</i>	<i>Timer1End</i>	<i>Reset on reception of the Timer End.</i>	
<i>Counter 1 End</i>	<i>Counter1End</i>	<i>Reset on the reception of the Counter end.</i>	
Counter Reset Input Line Activation	counterResetLineActivation	Specify the edge transition on the selected line that will reset the selected counter.	1.00 Expert DFNC
<i>Rising Edge</i>	<i>RisingEdge</i>	<i>Reset counter on rising edge of the selected signal.</i>	
<i>Falling Edge</i>	<i>FallingEdge</i>	<i>Reset counter on falling edge of the selected signal.</i>	
<i>Any Edge</i>	<i>AnyEdge</i>	<i>Reset counter on the falling or rising edge of the selected signal</i>	

Counter Value	counterValue	Read the current value of the selected counter.	1.00 Expert DFNC
Counter Value At Reset	counterValueAtReset	Stores the counter value of the selected counter when it was reset by a trigger or by an explicit Counter Reset command.	1.00 Expert DFNC
Counter Reset	counterReset	Resets the selected counter to zero. The counter starts immediately after the reset. To temporarily disable the counter, set the Counter Event Source feature to Off.	1.00 Expert DFNC
Timer Selector	timerSelector	Selects which timer to configure.	1.00 Expert DFNC
<i>Timer 1</i>	<i>Timer1</i>	<i>Timer 1 selected</i>	
Timer Mode	timerMode	Select the Timer mode. The selected Timer is Active or Disabled. When Disabled, the Timer can be configured.	1.00 Expert DFNC
<i>Off</i>	<i>Off</i>	<i>The selected Timer is Disabled.</i>	
<i>Active</i>	<i>Active</i>	<i>The selected Timer is Enabled.</i>	
Timer Status	timerStatus	Returns the current state of the timer.	1.00 Expert DFNC
<i>Timer Idle</i>	<i>TimerIdle</i>	<i>The timer is idle. The CounterStartSource feature is set to off.</i>	
<i>Timer Trigger Wait</i>	<i>TimerTriggerWait</i>	<i>The timer is waiting for a start trigger.</i>	
<i>Timer Active</i>	<i>TimerActive</i>	<i>The timer is counting for the specified duration.</i>	
<i>Timer Completed</i>	<i>TimerCompleted</i>	<i>The timer reached the TimerDuration count.</i>	
Timer Start Source	timerStartSource	Select the trigger source to start the timer. The Event Control section provides details and timing diagrams for the supported events.	1.00 Expert DFNC
<i>TimerReset Cmd</i>	<i>Off</i>	<i>Starts with the reception of the TimerReset Icommand.</i>	
<i>Exposure Start</i>	<i>ExposureStart</i>	<i>Start Timer on Exposure Start event.</i>	
<i>Exposure End</i>	<i>ExposureEnd</i>	<i>Start Timer on Exposure End event.</i>	
<i>Readout Start</i>	<i>ReadoutEnd</i>	<i>Start Timer on Readout Start event.</i>	
<i>Readout End</i>	<i>ReadoutStart</i>	<i>Start Timer on Readout End event.</i>	
<i>Frame Start</i>	<i>FrameStart</i>	<i>Start Timer on Frame Start event.</i>	
<i>Frame Trigger</i>	<i>ValidFrameTrigger</i>	<i>Start Timer on Frame Trigger event.</i>	
<i>CC1</i>	<i>CC1</i>	<i>Start Timer on a transition of I/O CC1 event.</i>	
<i>Counter 1 End</i>	<i>Counter1End</i>	<i>Start Timer on Counter 1 End event.</i>	
Timer Line Activation	timerStartLineActivation	Select the trigger activation mode which starts the timer.	1.00 Expert DFNC
<i>Rising Edge</i>	<i>RisingEdge</i>	<i>Starts counter on rising edge of the selected signal.</i>	
<i>Falling Edge</i>	<i>FallingEdge</i>	<i>Starts counter on falling edge of the selected signal.</i>	
<i>Any Edge</i>	<i>AnyEdge</i>	<i>Starts counter on the falling or rising edge of the selected signal.</i>	
Timer Duration	timerDuration	Sets the duration (in microseconds) of the timer pulse.	1.00 Expert DFNC
Timer Value	timerValue	Reads the current value (in microseconds) of the selected timer.	1.00 Expert DFNC
Timer Reset	timerReset	Resets the timer to 0 while <i>timerStatus=TimerActive</i> . Timer then waits for the next <i>timerStartSource</i> event.	1.00 Expert DFNC

Counter and Timer Group Block Diagram

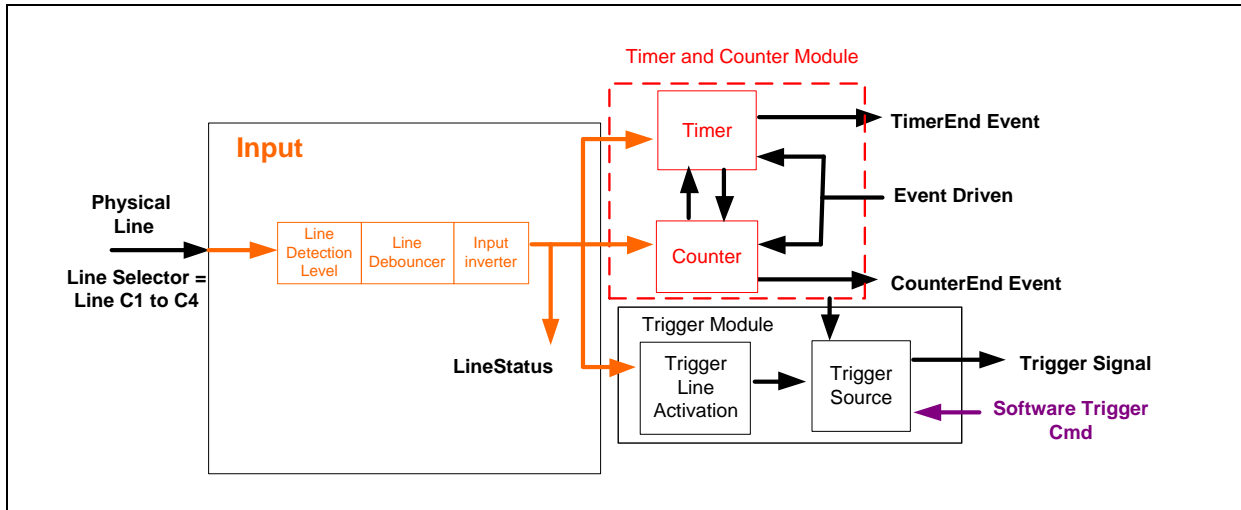

Example: Counter Start Source = OFF

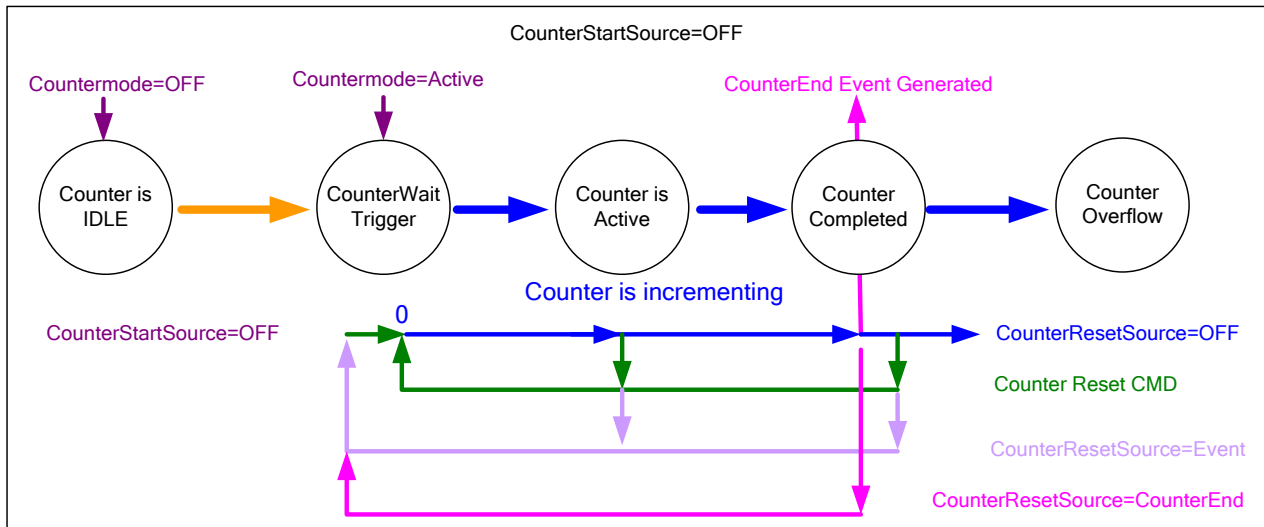

- The counter starts on the **counterReset Cmd**.
- The counter continues unless a new **counterReset Cmd** is received, which then restarts the counter at 00.
- When **Counter Reset Source= 'Event' or 'CounterEnd'** the counter is reset to 00 but does not restart counting, until the next **CounterReset Cmd**.

Example: Counter Start Source = CounterEnd (itself)

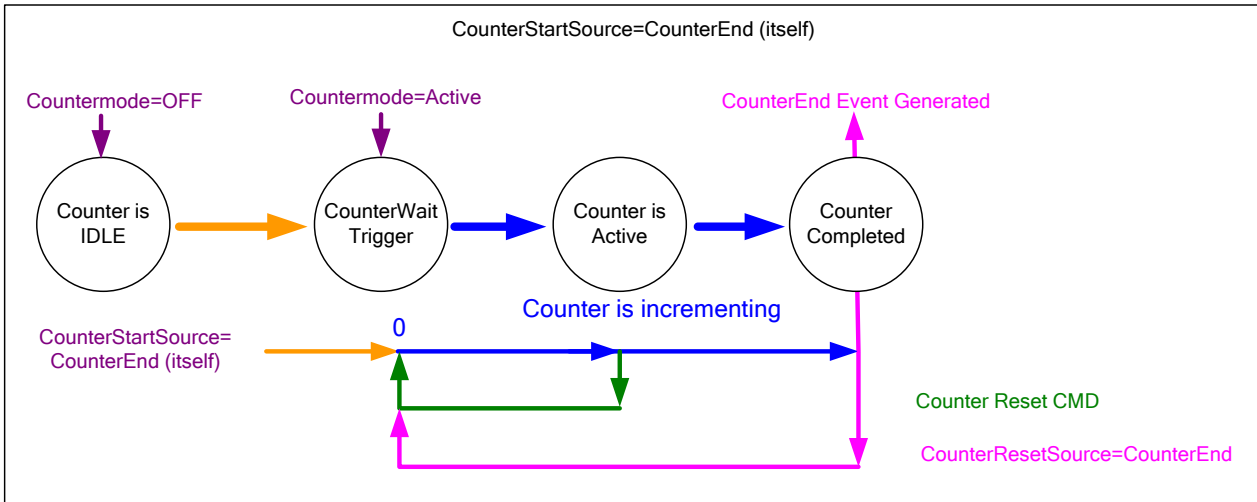

- Counter starts when Counter Mode is set to Active.
- A **Counter Reset CMD** will reset the counter to 00 and it then continues counting.
- **counterResetSource** must be set to **CounterEnd**. When the counterValue feature reaches the counterDuration value an event is generated and the counter is reset to 00, then continues.

Example: CounterStartSource = EVENT and Signal (Edge Base)

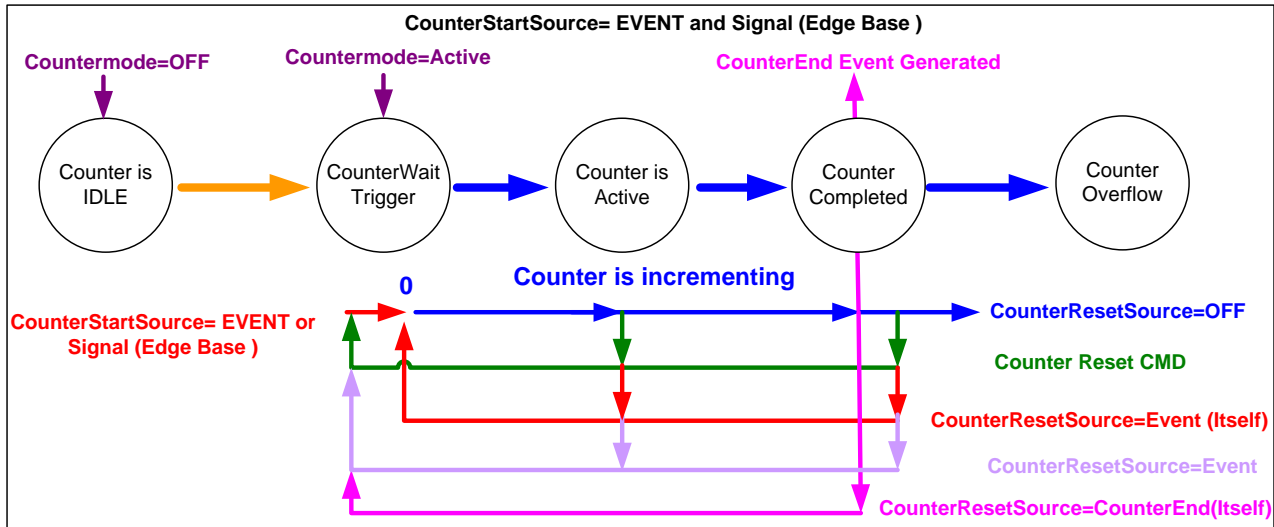

Example: CounterStartSource = Line (Edge Base) Example

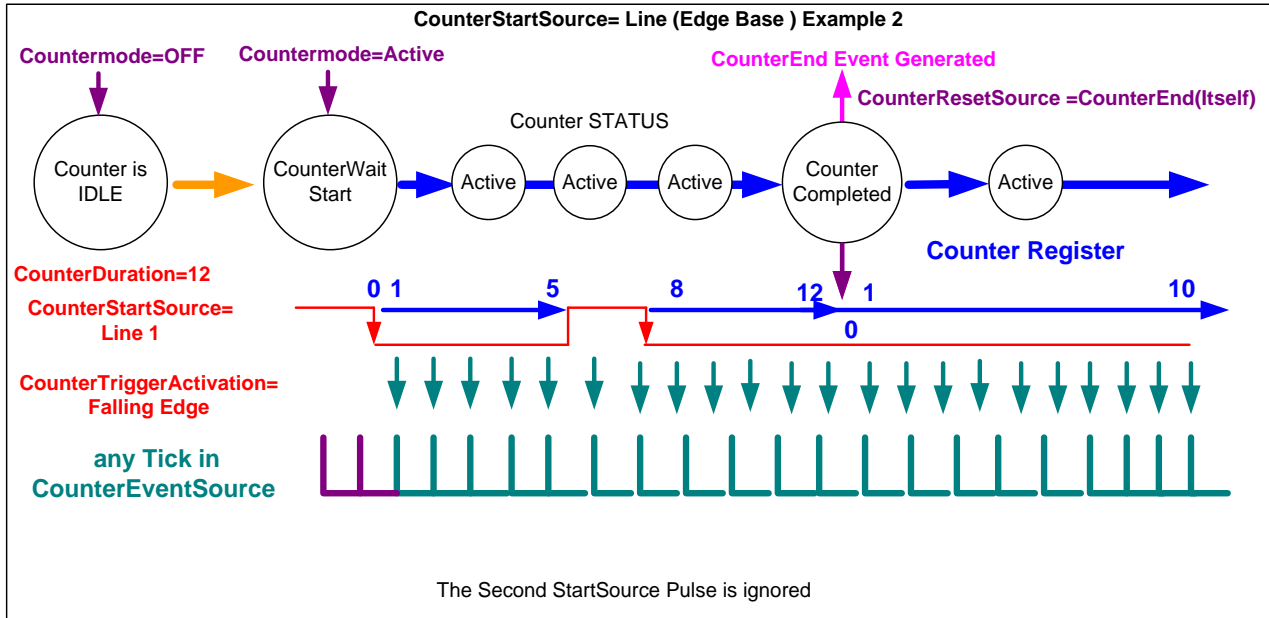

Example: Counting Elapse Time

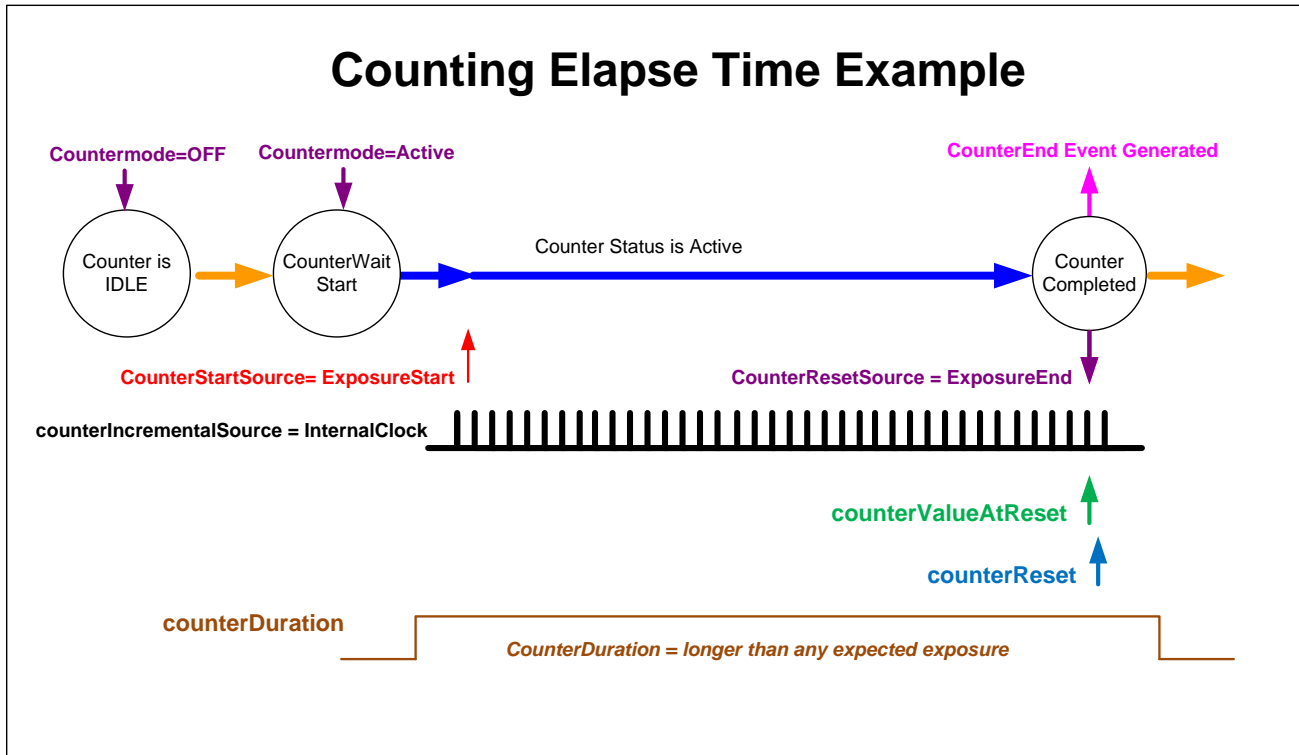

- **Counter mode=Active:** Enable the counter function.
- **counterIncrementalSource=InternalClock:** Counter driven by internally generated microsecond clock tick.
- **counterDuration="a period of time longer than any expected counter active period":** In cases where the count period is not fixed by the feature "counterDuration", this will create a failsafe event to end the counter if the "CounterEnd" event fails for any reason.
- **counterStartSource= ExposureStart:** In this example – sets the counter start event.
- **counterResetSource= ExposureEnd:** In this example – sets the counter end event.
- **counterValueAtReset:** Reads the last counter value before reset. In this example the count value equals time in microseconds since the counter start event.
- **counterReset:** Force a counter value reset when required.

Advanced Processing Control Category

The Genie Nano-CL Advanced Processing controls, as shown by CamExpert groups parameters used to configure pixel replacement, flat field correction (column based), and lens shading correction controls on monochrome cameras. Parameters in gray are read only, either always or due to another parameter being disabled. Parameters in black are user set in CamExpert or programmable via an imaging application.

Features listed in the description table but tagged as *Invisible* are usually for Teledyne DALSA or third party software usage—not typically needed by end user applications.

Also important, Nano-CL cameras are available in a number of models implementing different sensors and image resolutions which may not support the full feature set defined in this category. Color cameras will have their own specific processing capabilities.

Category	Parameter	Value
Camera Information	Defective Pixel Replacement Mode	Active
Sensor Control	Defective Pixel Replacement Map Current A...	Factory Map
I/O Controls	Noise Reduction Mode	Active
Counter And Timer Co...	Defective Column Replacement Option	Allow
<< Less		

Category	Parameter	Value
Camera Information	Flat Field Correction Mode	Active
Sensor Control	Flat Field Correction Current Active ...	Factory Flatfield
I/O Controls	Flatline Correction Calibration Dark	Not Enabled
Counter And Timer Control	Flatline Correction Calibration Bright	Not Enabled
Advanced Processing	Save Calibration	Not Enabled
Flat Field Correction	Reset Calibration	Not Enabled
Lens Shading Correction	Flat Field Correction Type	Line-Based
Image Format Controls	Flat Field Correction Algorithm	Method 1
<< Less		

Category	Parameter	Value
Camera Information	Lens Shading Correction Mode	Active
Sensor Control	Lens Shading Coefficient Current Active Set	User Shading Coeffic...
I/O Controls	Lens Shading Calibration Sample Size	Not Enabled
Counter And Timer Control	Lens Shading Correction Calibration Bright	Not Enabled
<input checked="" type="checkbox"/> Advanced Processing	Lens Shading Correction Calibration Dark	Not Enabled
Flat Field Correction	Save Calibration	Not Enabled
Lens Shading Correction	Reset Coefficients	Not Enabled
Image Format Controls	<< Less	
Camera Link Transport Layer		
File Access Control		

Notes about Lens Shading Calibration

Note: It is recommended that a “Lens Shading Calibration” procedure be done for any Nano-CL/Lens combination. Calibration will eliminate any lens vignetting in the image corners or any other shading differences across the image field. Calibration will allow using a lens with a slightly smaller image circle that doesn’t quite evenly expose the whole sensor. The graphic below shows how a lens used on the 16M model could be used with a 25M model after shading calibration (results will vary with different lenses).

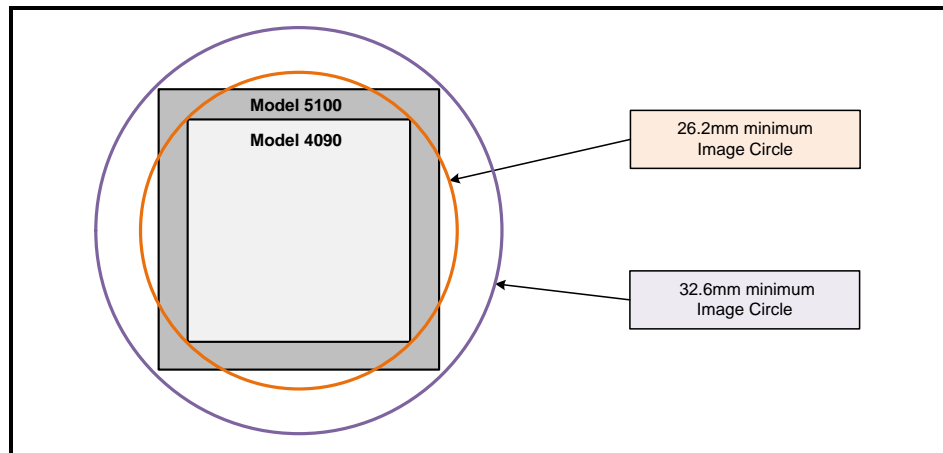

CamExpert allows quick calibration by the user. The features for the [Lens Shading Correction Group](#) can also be accessed by the user designed application. The feature descriptions are shown below and after calibration the data should be saved in a user set.

- **Lens Shading Correction Calibration Dark:** Perform a dark calibration for lens shading correction. Typically done before the bright calibration, this calibration requires a dark acquisition (as little light on the sensor as possible).
- **Lens Shading Correction Calibration Bright:** Perform a bright calibration for lens shading correction. This calibration requires a bright featureless acquisition that is not saturated. (70% illumination is recommended).

Advanced Processing Control Feature Descriptions

The following table describes these features along with their view attribute and device version. For each feature the device version may differ for each camera sensor available. Such feature differences will be clearly indicated.

As Nano-CL capabilities evolve the device firmware version will increase, therefore identifying the supported function package. New features for a major device version release will be indicated by **green text** for easy identification, for that new manual release.

The description column will indicate which feature is a member of the Teledyne DALSA Features Naming Convention (indicated by DFNC), versus the GenICam Standard Features Naming Convention (SFNC not shown).

Advanced Processing Group

Display Name	Feature & Values	Description	Version
Defective Pixel Replacement Mode	defectivePixelReplacementMode	Sets the mode for the defective pixel replacement.	Ver. 1.00 Expert DFNC
<i>Off</i>	<i>Off</i>	<i>Defective Pixel Replacement is disabled.</i>	
<i>Active</i>	<i>Active</i>	<i>Defective Pixel Replacement is enabled.</i>	
Defective Pixel Replacement Map Current Active Set	defectivePixelReplacementMapCurrentActiveSet	Sets the defective pixel replacement set.	Ver. 1.00 Expert DFNC
<i>Factory Map</i>	<i>FactoryMap</i>	<i>Sets the factory coefficient table as active.</i>	
<i>User Map 1</i>	<i>UserMap1</i>	<i>Sets the User Map coefficient table as active.</i>	
Defective Pixel Replacement Algorithm	defectivePixelReplacementAlgorithm	Specifies the defective pixel replacement algorithm.	Ver. 1.00 Expert DFNC
<i>Method3: Neighboring Pixel</i>	<i>Method3</i>	<i>This algorithm replaces a defective pixel with a neighbor.</i>	
Noise Reduction Mode	noiseReduction	Sets the mode for the pixel noise reduction.	Ver. 1.00 Expert DFNC
<i>Off</i>	<i>Off</i>	<i>Noise Reduction is disabled.</i>	
<i>Active</i>	<i>Active</i>	<i>Noise Reduction is enabled.</i>	
Defective Column Replacement Option	defectiveColumnReplacementOption	When defectivePixelReplacementMode is Active, this feature allows control over defective column replacement.	Ver. 1.00 Expert DFNC
<i>Disable</i>	<i>Disable</i>	<i>Defective Column Replacement is disabled.</i>	
<i>Allow</i>	<i>Allow</i>	<i>Defective Column Replacement is allowed.</i>	

Flat Field Correction Group

Display Name	Feature & Values	Description	Device Version & View
Flat Field Correction Mode	flatfieldCorrectionMode	Sets the mode for the Flat Field correction. See flatfieldCorrectionType below.	1.00 Beginner DFNC
<i>Off</i>	<i>Off</i>	Flat Field Correction is disabled.	
<i>Active</i>	<i>Active</i>	Flat Field Correction is enabled.	
<i>Calibration</i>	<i>Calibration</i>	When this mode is selected, the camera is configured for flat field correction calibration. The device may automatically adjust some of its features when calibrate mode is enabled. The features that are automatically adjusted are device specific. The device will not restore these features when the Flat Field Correction Mode feature is changed from Calibrate mode to another mode.	
Flat Field Correction Current Active Set	flatfieldCorrectionCurrentActiveSet	Specifies the current set of Flat Field coefficients to use.	1.00 Beginner DFNC
<i>Factory Flatfield</i>	<i>FactoryFlatfield</i>	Sets the factory Flat Field coefficient table as the current Flat Field.	
<i>User Flatfield 1</i>	<i>UserFlatfield1</i>	Sets User Flat Field 1 coefficient table as the current Flat Field.	
Flat Field Correction Type	flatfieldCorrectionType	Specifies the Flat Field correction type.	1.00 Guru DFNC
<i>Line-Based</i>	<i>LineBase</i>	Flat field correction is based on the average of lines of gain and offset coefficients where corrections are applied to each pixel in the column. (Correcting column to column variations).	
Flat Field Correction Algorithm	flatfieldCorrectionAlgorithm	Specifies the Flat Field correction algorithm to use.	1.00 Guru DFNC
<i>Method 1</i>	<i>Method1</i>	The following formula is used to calculate the flat field corrected pixel: $newPixelValue[x][y] = (sensorPixelValue[x][y] - FFOffset[x][y]) * FFCGain[x][y]$	
Flat Field Correction Calibration Dark	flatfieldCorrectionCalibrationDark	Perform a dark calibration. This is typically done before the bright calibration. This calibration requires a dark acquisition (as little light on the sensor as possible).	1.00 Expert DFNC
Flat Field Correction Calibration Bright	flatfieldCorrectionCalibrationBright	Perform a bright calibration. This is typically done after the dark calibration. This calibration requires a bright featureless acquisition that is not saturated.	1.00 Expert DFNC
Save Calibration	flatfieldCorrectionCalibrationSave	Save the calibration results of the flatfieldCorrectionCalibrationDark and/or flatfieldCorrectionCalibrationBright operations to the current active set.	1.00 Expert DFNC
Reset Calibration	flatfieldCorrectionCalibrationResetCoefficients	Reset the current calibration coefficients to factory defaults.	1.00 Expert DFNC
Flat Field Algorithm Buffer Format	flatfieldAlgorithmBufferFormat		1.00 Invisible DFNC
<i>Mono8</i>	<i>Mono8</i>		
Flat Field Algorithm Buffer Width	flatfieldAlgorithmBufferWidth		1.00 Invisible DFNC
Flat Field Algorithm Buffer Height	flatfieldAlgorithmBufferHeight		1.00 Invisible DFNC

Flat Field Algorithm Gain Max	flatfieldAlgorithmGainMax		1.00 Invisible DFNC
Flat Field Algorithm Gain Min	flatfieldAlgorithmGainMin		1.00 Invisible DFNC
Flat Field Algorithm Gain Divisor	flatfieldAlgorithmGainDivisor		1.00 Invisible DFNC
Flat Field Algorithm Gain Base	flatfieldAlgorithmGainBase		1.00 Invisible DFNC
Flat Field Algorithm Offset Max	flatfieldAlgorithmOffsetMax		1.00 Invisible DFNC
Flat Field Algorithm Offset Min	flatfieldAlgorithmOffsetMin		1.00 Invisible DFNC
Flat Field Algorithm Offset Factor	flatfieldAlgorithmOffsetFactor		1.00 Invisible DFNC

Lens Shading Correction Group

Display Name	Feature & Values	Description	Device Version & View
Lens Shading Correction Mode	lensShadingCorrectionMode	Sets the mode for the lens shading correction.	1.00 Expert DFNC
<i>Off</i>	<i>Off</i>	<i>Lens Shading Correction is Disabled</i>	
<i>Active</i>	<i>Active</i>	<i>Lens Shading Correction is Enabled</i>	
<i>Calibration</i>	<i>Calibration</i>	<i>When selected, the camera is configured for Lens Shading correction calibration. Some processing will be disabled even if the associated feature is enabled.</i>	
Lens Shading Coefficient Current Active Set	lensShadingCorrectionCurrentActiveSet	Specifies the current set of Lens Shading Coefficients to use.	1.00 Beginner DFNC
<i>Factory Shading Coefficients</i>	<i>FactoryShadingCoefficients</i>	<i>Sets the Factory Shading Coefficients as current.</i>	
<i>User Shading Coefficients 1</i>	<i>ShadingCoefficients1</i>	<i>Sets User Shading Coefficients set 1 as current.</i>	
<i>User Shading Coefficients 2</i>	<i>ShadingCoefficients2</i>	<i>Sets User Shading Coefficients set 2 as current.</i>	
Lens Shading Calibration Sample Size	lensShadingCorrectionCalibrationSampleSize	Number of frames to average for Lens Shading calibration	1.00 Guru DFNC
Lens Shading Correction Calibration Bright	lensShadingCorrectionCalibrationBright	Perform a bright calibration for lens shading correction. This calibration requires a bright featureless acquisition that is not saturated. (70% illumination is recommended).	1.00 Expert DFNC
Lens Shading Correction Calibration Dark	lensShadingCorrectionCalibrationDark	Perform a dark calibration for lens shading correction. Typically done before the bright calibration. This calibration requires a dark acquisition (as little light on the sensor as possible).	1.00 Expert DFNC
Save Calibration	lensShadingCorrectionCalibrationSave	Save the calibration results of the lensShadingCorrectionCalibrationBright and/or lensShadingCorrectionCalibrationDark operations to the active set.	1.00 Expert DFNC
Reset Coefficients	lensShadingResetCoefficients	Reset lens shading coefficients to pass-through.	1.00 Expert DFNC

Lens Shading Correction Algorithm Buffer Format	lensShadingCorrectionAlgorithmBufferFormat		1.00 Invisible DFNC
<i>Mono8</i>	<i>Mono8</i>		
Lens Shading Correction Algorithm Buffer Width	lensShadingCorrectionAlgorithmBufferWidth		1.00 Invisible DFNC
Lens Shading Algorithm Buffer Height	lensShadingCorrectionAlgorithmBufferHeight		1.00 Invisible DFNC
Lens Shading Algorithm Gain Max	lensShadingCorrectionAlgorithmGainMax		1.00 Invisible DFNC
Lens Shading Algorithm Gain Min	lensShadingCorrectionAlgorithmGainMin		1.00 Invisible DFNC
Lens Shading Algorithm Gain Divisor	lensShadingCorrectionAlgorithmGainDivisor		1.00 Invisible DFNC
Lens Shading Algorithm Gain Base	lensShadingCorrectionAlgorithmGainBase		1.00 Invisible DFNC
Lens Shading Algorithm Offset Max	lensShadingCorrectionAlgorithmOffsetMax		1.00 Invisible DFNC
Lens Shading Algorithm Offset Min	lensShadingCorrectionAlgorithmOffsetMin		1.00 Invisible DFNC
Lens Shading Correction Algorithm Offset Factor	lensShadingCorrectionAlgorithmOffsetFactor		1.00 Invisible DFNC

Defective Pixel Replacement

The Pixel Replacement algorithm is based on a predefined bad pixel map (as an XML file), either supplied by the factory (file loaded as “Factory Map”) or generated by the user (file uploaded as “User Map 1”). The number of bad pixel entries is limited and varies dependent on the Nano model. The following XML code sample forms the template for the user to build bad pixel maps for any of their Nano cameras.

Note: Identifying bad pixels is left to the user’s discretion, but Teledyne DALSA technical support can provide guidance.

Example User Defective Pixel Map XML File

The following example shows the required components of the defective pixel map file. Each bad pixel position (relative to the image origin which is the upper left corner), must be identified by the XML statement:

```
<DefectivePixel OffsetX="number" OffsetY="number"/>
```

The pixel format (whether 8, 10, 12-bit) is handled transparently, thus requires no special consideration by the user.

This example XML listing has four “bad” pixels identified (maximum number of entries is model dependent). The various algorithm descriptions define the rules used by the Nano firmware to replace an identified bad pixel.

```
<?xml version="1.0" encoding="UTF-8" ?>
<!--Example User Defective Pixel Map -->
<!-- Maximum number of coordinates dependent on sensor "Defective Pixel Replacement" value -->
<!--filename: NanoExampleBadPixels.xml -->

<Coordinates>

<DefectivePixel OffsetX="100" OffsetY="0"/>
<DefectivePixel OffsetX="28" OffsetY="345"/>
<DefectivePixel OffsetX="468" OffsetY="50"/>
<DefectivePixel OffsetX="800" OffsetY="600"/>

</Coordinates>
```

A sample editable defective pixel map replacement file will be available to download with Nano firmware files.

Monochrome Defective Pixel Replacement Algorithm Description

The replacement algorithm follows a few basic rules as defined below, which in general provides satisfactory results.

Single bad pixel in a sensor line with a good adjacent pixel

- A defective pixel is replaced by the following good pixel if previous pixel is bad or not existent.
- Or a defective pixel is replaced by the previous good pixel.

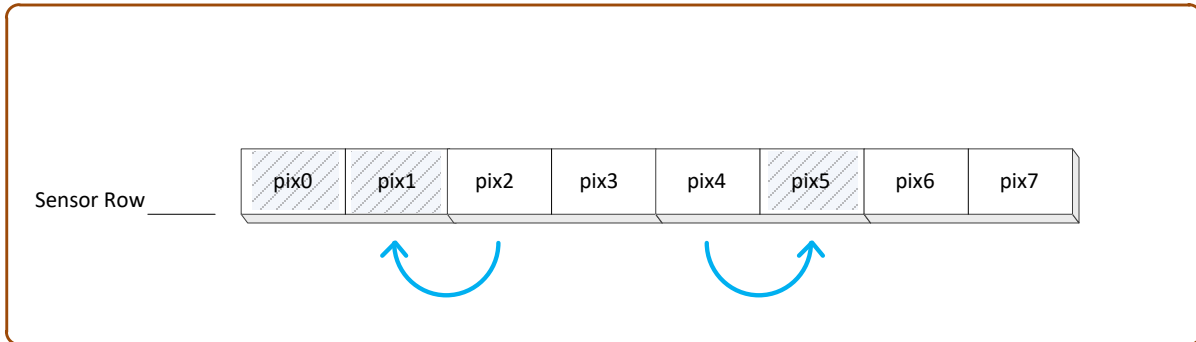

Bad pixel in a sensor line with bad adjacent pixels

- Replace bad pixel with the corresponding pixel of the previous line.
- Do nothing when the neighboring pixels are also bad.

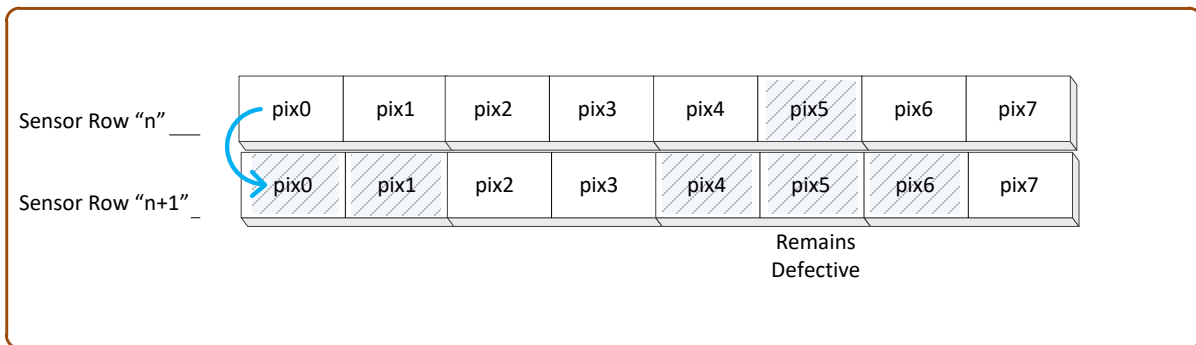

Color Defective Pixel Replacement Algorithm Description

The replacement algorithm rules for Bayer a color sensor is similar to the monochrome rules with the exception that replacement pixels of the same color as the bad are used. The two replacement cases below describe general color pixel replacements.

Single bad pixel in a sensor line with a good adjacent pixel

- A defective pixel is replaced by the following good pixel if previous pixel is bad or not existent.
- Or a defective pixel is replaced by the previous good pixel.

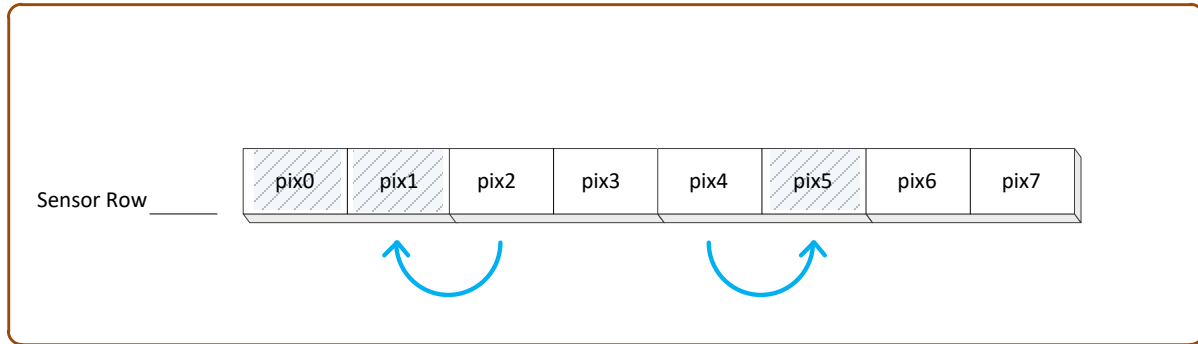

Bad pixel in a sensor line with bad adjacent pixels

- Do nothing when the neighboring pixels are also bad.

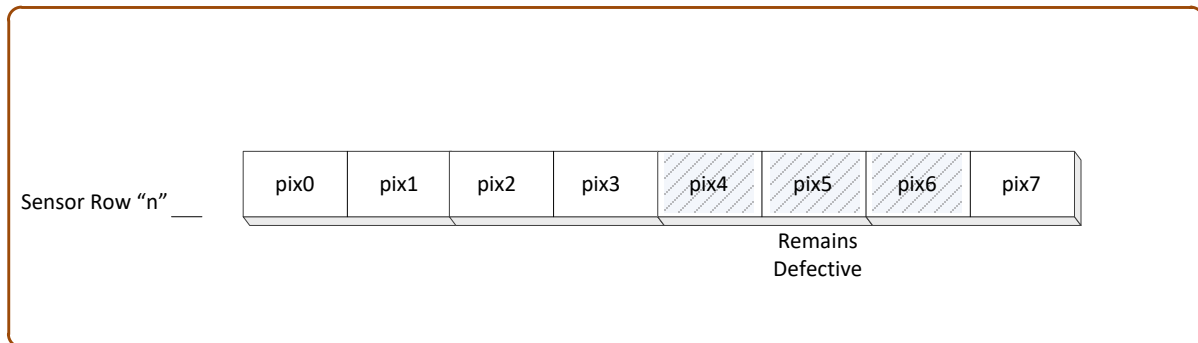

Image Format Control Category

The Nano-CL Image Format controls, as shown by CamExpert, groups parameters used to configure camera pixel format, image cropping, and selecting a test output image without a lens.

Parameters in gray are read only, either always or due to another parameter being disabled. Parameters in black are user set in CamExpert or programmable via an imaging application.

Features listed in the description table but tagged as *Invisible* are usually for Teledyne DALSA or third party software usage—not typically needed by end user applications. Also important, Genie Nano cameras are available in a number of models implementing different sensors and image resolutions which may not support the full feature set defined in this category.

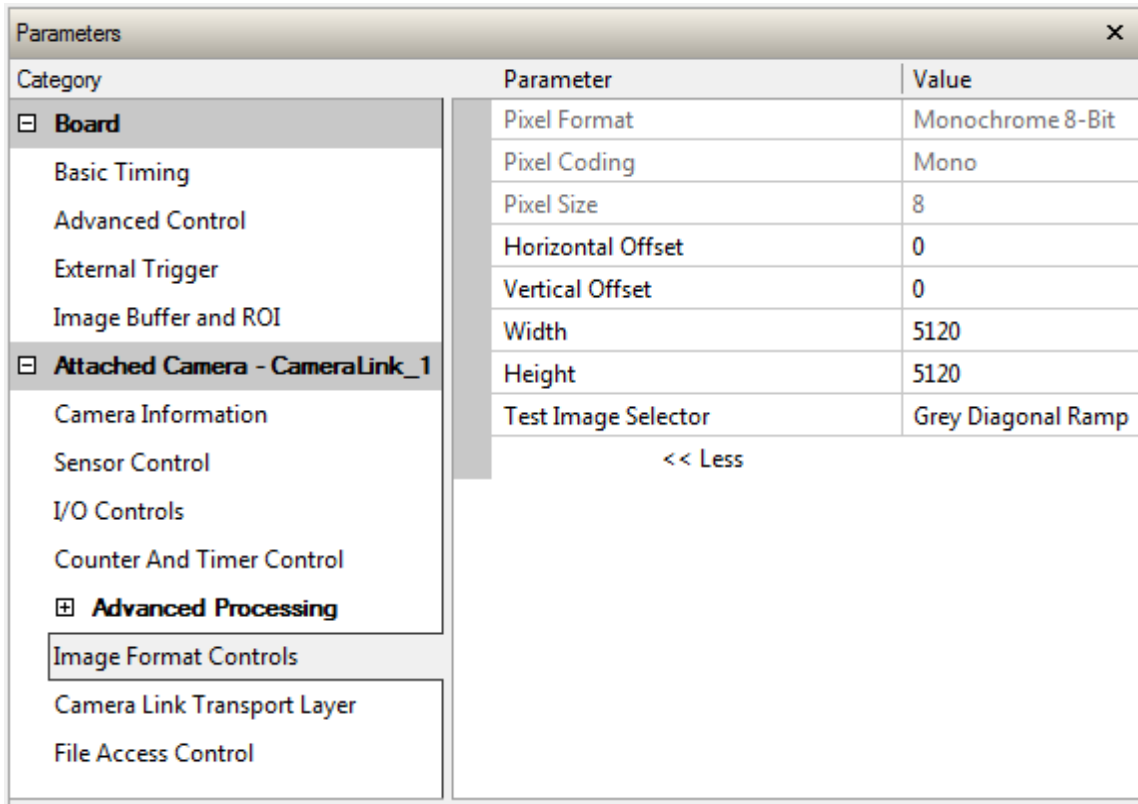



















Image Format Control Feature Description

The following table describes these features along with their view attribute and device framework version. For each feature the device version may differ for each camera sensor available. Such differences will be clearly indicated for any applicable feature.

A Revision Version number represents the camera software firmware revision. As Genie Nano capabilities evolve the version will increase, therefore identifying the supported function package. New features for a major device version release will be indicated by **green text** for easy identification.

The first column indicates whether a feature applies to monochrome or color camera models via a symbol. No symbol indicates a common feature. Additionally the description column will indicate

which feature is a member of the DALSA Features Naming Convention (denoted by DFNC), versus the GenICam Standard Features Naming Convention (SFNC tag is not shown).

B/W Color	Display Name	Feature & Values	Description	Device Version & View
	Pixel Format	PixelFormat	Format of the pixel provided by the device. Contains all format information as provided by PixelCoding, PixelSize, PixelColorFilter, combined in one single value.	1.00 Beginner Read Only
	<i>Monochrome 8-Bit</i>	<i>Mono8</i>	<i>Mono8: Monochrome 8-Bit</i>	
	<i>Monochrome 10-Bit</i>	<i>Mono10</i>	<i>Mono10: Monochrome 10-Bit</i>	
	<i>Monochrome 12-Bit</i>	<i>Mono12</i>	<i>Mono12: Monochrome 10-Bit</i>	
	<i>BayerGR 8-Bit</i>	<i>BayerGR8</i>	<i>Color camera: BayerGR8</i>	
	<i>BayerRG 8-Bit</i>	<i>BayerRG8</i>	<i>Color camera: BayerRG8t</i>	
	<i>BayerGB 8-Bit</i>	<i>BayerGB8</i>	<i>Color camera: BayerGB8</i>	
	<i>BayerBG 8-Bit</i>	<i>BayerBG8</i>	<i>Color camera: BayerBG8</i>	
	<i>BayerGR 10-Bit</i>	<i>BayerGR10</i>	<i>Color camera: BayerGR10</i>	
	<i>BayerRG 10-Bit</i>	<i>BayerRG10</i>	<i>Color camera: BayerRG10</i>	
	<i>BayerGB 10-Bit</i>	<i>BayerGB10</i>	<i>Color camera: BayerGB10</i>	
	<i>BayerGR 10-Bit</i>	<i>BayerGR10</i>	<i>Color camera: BayerGR10</i>	
	<i>BayerRG 12-Bit</i>	<i>BayerRG12</i>	<i>Color camera: BayerRG12</i>	
	<i>BayerGB 12-Bit</i>	<i>BayerGB12</i>	<i>Color camera: BayerGB12</i>	
	<i>BayerBG 12-Bit</i>	<i>BayerBG12</i>	<i>Color camera: BayerBG12</i>	
	<i>BayerBG 12-Bit</i>	<i>BayerBG12</i>	<i>Color camera: BayerBG12</i>	
	Pixel Coding	PixelCoding	Output image pixel coding format of the sensor. See clPixelSize in the " Camera Link Transport Layer " section to change the pixel size output.	1.00 Guru Read Only
	<i>Mono</i>	<i>Mono</i>	<i>Pixel is monochrome</i>	
	<i>Raw Bayer</i>	<i>Raw</i>	<i>Pixel is raw Bayer</i>	
	Pixel Size	PixelSize	Total size in bits of an image pixel.	1.00 Guru Read Only
	<i>8 Bits/Pixel</i>	<i>Bpp8</i>	<i>Bpp8: 8 bits per pixel</i>	
	<i>10 Bits/Pixel</i>	<i>Bpp10</i>	<i>Bpp10: 10 bits per pixel</i>	
	<i>12 Bits/Pixel</i>	<i>Bpp12</i>	<i>Bpp12: 12 bits per pixel</i>	

	Horizontal Offset	OffsetX	Horizontal offset from the Sensor Origin to the Region Of Interest (in pixels).	1.00 Beginner
	Vertical Offset	OffsetY	Vertical offset from the Sensor Origin to the Region Of Interest (in Lines).	1.00 Beginner
	Width	Width	Width of the Image provided by the device (in pixels).	1.00 Beginner
	Height	Height	Height of the Image provided by the device (in lines).	1.00 Beginner
	Test Image Selector	TestImageSelector	Selects the type of test image generated by the camera.	1.00 Beginner
	<i>Off</i>	<i>Off</i>	<i>Image is from the camera sensor.</i>	
	<i>Grey Horizontal Ramp</i>	<i>GreyHorizontalRamp</i>	<i>Image is filled horizontally with an image that goes from the darkest possible value to the brightest.</i>	
	<i>Grey Vertical Ramp</i>	<i>GreyVerticalRamp</i>	<i>Image is filled vertically with an image that goes from the darkest possible value to the brightest.</i>	
	<i>Grey Diagonal Ramp Moving</i>	<i>GreyDiagonalRampMoving</i>	<i>Image is filled horizontally with an image that goes from the darkest possible value to the brightest by 1 Dn increment per pixel and that moves horizontally.</i>	
	Width Max	WidthMax	The maximum image width is the dimension calculated after horizontal binning, decimation or any other function changing the horizontal dimension of the image.	1.00 Invisible
	Height Max	HeightMax	The maximum image height is the dimension calculated after vertical binning, decimation or any other function changing the vertical dimension of the image.	1.00 Invisible

Width and Height Features for Partial Scan Control

Width and Height controls along with their respective offsets, allow the Nano-CL to grab a region of interest (ROI) within the full image frame. Besides eliminating post acquisition image cropping done by software in the host computer, a windowed ROI grab reduces the bandwidth required since less pixels are transmitted.

Vertical Cropping (Partial Scan)

The Height and Vertical Offset features, used for vertical cropping, reduce the number of video lines grabbed for a frame. By not scanning the full height of the sensor, the maximum possible acquisition frame rate is proportionately increased, up to the Genie Nano model maximum.

The following figure is an example of a partial scan acquisition using both Height and Vertical Offset controls. The Vertical Offset feature defines at what line number from the sensor origin to acquire the image. The Height feature defines the number of lines to acquire (to a maximum of the remaining frame height). Note that only the partial scan image (ROI) is transmitted to the host computer.

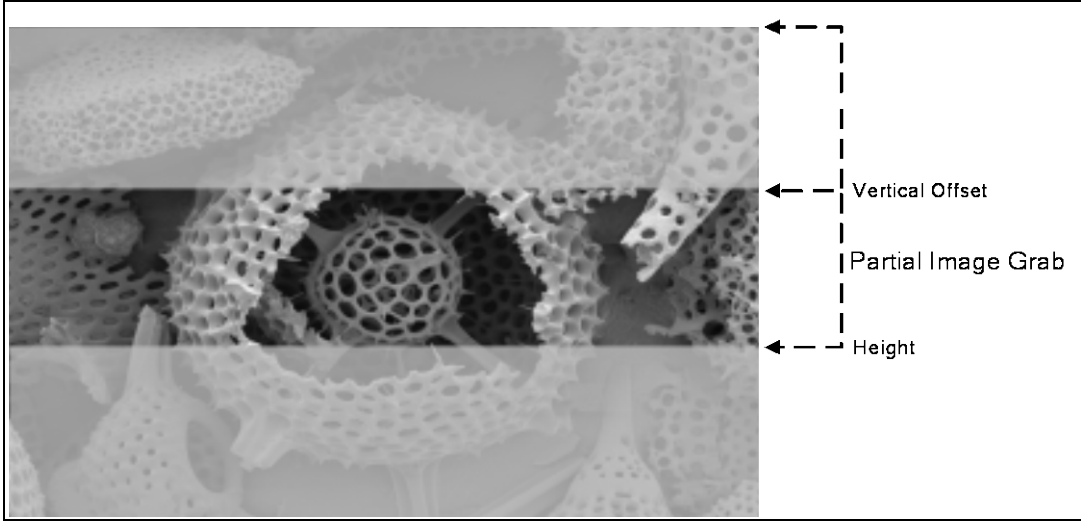

Partial Scan Illustration

Maximum Frame Rate Examples (Nano-CL-M/C 5100)

Using 10-Tap 8-bit Firmware

Vertical Lines Acquired (inc=16)	Internal Trigger / Minimum Exposure Python 25k sensor – model M5100	Internal Trigger / Minimum Exposure Python 25k sensor – model M5100 Fast Readout Mode Enabled
5120	23.4 fps	32.0 fps
3840	31.2 fps	42.7 fps
2560	46.8 fps	63.9 fps
1280	93.2 fps	127.2 fps
640	184.9 fps	251.5 fps
320	363.3 fps	492.1 fps
160	702.2 fps	943.3 fps
80	1315 fps	1739 fps
48	2020 fps	2631 fps
32	2762 fps	3533 fps
16	4366 fps	5376 fps

Note: Fast Readout Mode will have low DN Fixed Pattern column artifacts as described here [OnSemi Sensor Fast Readout Mode](#).

Using 8-Tap 10-bit Firmware

Vertical Lines Acquired (inc=16)	Internal Trigger / Minimum Exposure Python 25k sensor – model M5100	Internal Trigger / Minimum Exposure Python 25k sensor – model M5100 Fast Readout Mode Enabled
5120	23.4 fps	25.5 fps
3840	31.2 fps	34.0 fps
2560	46.8 fps	50.9 fps
1280	93.3 fps	101.4 fps
640	185.0 fps	201.0 fps
320	364.0 fps	395.0 fps
160	704.7 fps	762.7 fps
80	1324 fps	1428 fps
48	2040 fps	2192 fps
32	2801 fps	2994 fps
16	4464 fps	4716 fps

Maximum Frame Rate Examples (Nano-CL-M/C 4090)

Using 10-Tap 8-bit Firmware

Vertical Lines Acquired	Internal Trigger / Minimum Exposure Python 16k sensor –model M4090	Internal Trigger / Minimum Exposure Python 16k sensor – model M4090 Fast Readout Mode Enabled
4096	32.8 fps	46.9 fps
3840	35.0 fps	50.0 fps
2560	52.4 fps	74.9 fps
1280	104.4 fps	148.8 fps
640	206.7 fps	293.7 fps
320	405.3 fps	572.4 fps
160	780.0 fps	1089 fps
80	1450 fps	1988 fps
48	2212 fps	2958 fps
32	3003 fps	3921 fps
16	4651 fps	5813 fps

Note: Fast Readout Mode will have low DN Fixed Pattern column artifacts as described here [OnSemi Sensor Fast Readout Mode](#).

Using 8-Tap 10-bit Firmware

Vertical Lines Acquired	Internal Trigger / Minimum Exposure Python 16k sensor –model M4090	Internal Trigger / Minimum Exposure Python 16k sensor – model M4090 Fast Readout Mode Enabled
4096	32.8 fps	36.1 fps
3840	35.0 fps	38.5 fps
2560	52.4 fps	57.6 fps
1280	104.4 fps	114.7 fps
640	206.9 fps	227.1 fps
320	406.1 fps	445.2 fps
160	783.0 fps	856.1 fps
80	1461 fps	1589 fps
48	2237 fps	2421 fps
32	3048 fps	3278 fps
16	4761 fps	5076 fps

Maximum Frame Rate Examples (Nano-CL-M/C 2450)

Vertical Lines Acquired	Internal Trigger – Minimum Exposure 10-Tap 8-bit
2056	141.8 fps
2048	142.4 fps
1024	279.7
512	539.9
256	1010.1
128	1788.9
64	2906.9
32	4237.2
16	5494.5
8	6451.61
4	7042.5

Maximum Frame Rate Examples (Nano-CL-M/C 4060)

Vertical Lines Acquired	Internal Trigger – Minimum Exposure 10-Tap 8-bit
2176	87.6 fps
2048	92.9 fps
1024	181.2 fps
512	345.0 fps
256	629.7 fps
128	1072 fps
64	1655 fps
32	2267 fps
16	2785 fps
8	3144 fps
4	3367 fps

Maximum Frame Rate Examples (Nano-CL-M/C 4040)

Vertical Lines Acquired	Internal Trigger – Minimum Exposure 10-Tap 8-bit
3008	63.8 fps
2048	92.9 fps
1024	181.2 fps
512	345.0 fps
256	629.7 fps
128	1072 fps
64	1655 fps
32	2267 fps
16	2785 fps
8	3144 fps
4	3367 fps

Horizontal Cropping (Partial Scan)

Genie Nano supports cropping the acquisition horizontally by grabbing less pixels on each horizontal line. Horizontal offset defines the start of the acquired video line while horizontal width defines the number of pixels per line. Horizontal control features have the following independent constants:

- Horizontal Offset is limited to pixel increment values of 8, 16 or 64 to define the start of the video line.
- Horizontal Width decrements from maximum in pixel counts of 8 (i.e. the video width is in steps of 8 pixels).

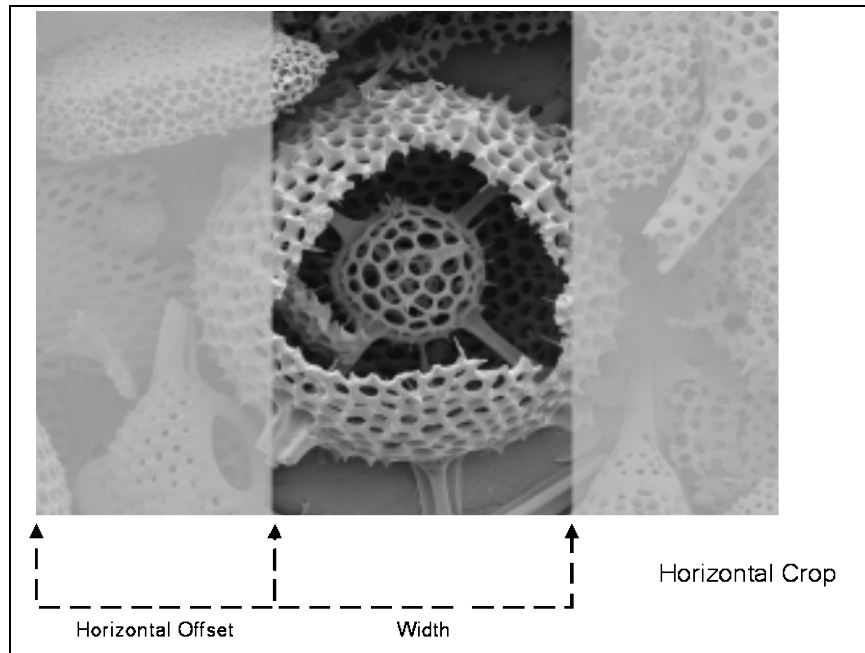

Internal Test Pattern Generator

The Genie Nano camera includes a number of internal test patterns which easily confirm camera installations, without the need for a camera lens or proper lighting.

Use CamExpert to easily enable and select the any of the Nano test patterns from the drop menu while the camera is not in acquisition mode. Select live grab to see the pattern output.

Note that internal test patterns are generated by the camera FPGA where the patterns are inserted immediately after the sensor output in the processing chain and are the same maximum bit depth as the sensor. The patterns are identical for monochrome or color camera models and subject to processing operations.

- Note: Selecting the camera 8-bit output format displays the lower 8-bits of the processing path.
- Note: Processing such as Flat Field corrections and Shading corrections are not disabled automatically. Therefore the test pattern ramps will seem to be lacking various gray levels unless all processing features are off.

The Nano Test Patterns are:

- **Grey Horizontal ramp:** *Image is filled horizontally with an image that goes from the darkest possible value to the brightest.*



- **Grey Vertical ramp:** *Image is filled vertically with an image that goes from the darkest possible value to the brightest.*



- **Grey Diagonal Ramp Moving:** combination of the 2 previous schemes, but first pixel in image is incremented by 1 between successive frames. This is a good pattern to indicate motion when doing a continuous grab.



Transport Layer Control Category

The Camera Link Transport Layer Controls relate to settings and status of the Camera Link connection to the system frame grabber. Parameters in gray are read only, either always or due to another parameter being disabled. Parameters in black are user set in CamExpert or programmable via an imaging application.

Features listed in the description table but tagged as *Invisible* are usually for Teledyne DALSA or third party software usage—not typically needed by end user applications.

Transport Layer Control Feature Descriptions

The Device Version number represents the camera software functional group, not a firmware revision number. As Nano-CL capabilities evolve the device version tag will increase, therefore identifying the supported function package. New features for a major device version release will be indicated by **green text** for easy identification.

Display Name	Feature & Values	Description	Device Version & View
Serial Port Selector	DeviceSerialPortSelector	Selects which serial port of the device to control.	1.00 Beginner
<i>Camera Link</i>	<i>CameraLink</i>	<i>Serial port associated with the Camera link connection used to communicate with the device.</i>	
Baud Rate	DeviceSerialPortBaudRate	This feature controls the baud rate used by the selected device's serial port.	1.00 Beginner
<i>9600</i>	<i>Baud_9600</i>	<i>Baud_9600</i>	
<i>19200</i>	<i>Baud_19200</i>	<i>Baud_19200</i>	
<i>38400</i>	<i>Baud_38400</i>	<i>Baud_38400</i>	
<i>57600</i>	<i>Baud_57600</i>	<i>Baud_57600</i>	
<i>115200</i>	<i>Baud_115200</i>	<i>Baud_115200</i>	
<i>230400</i>	<i>Baud_230400</i>	<i>Baud_230400</i>	
<i>460800</i>	<i>Baud_460800</i>	<i>Baud_460800</i>	
<i>921600</i>	<i>Baud_921600</i>	<i>Baud_921600</i>	
Heartbeat Mode	DeviceLinkHeartbeatMode	Activate or deactivate the control channel heartbeat.	1.00 Expert
<i>On</i>	<i>On</i>	<i>Enables the heartbeat</i>	
<i>Off</i>	<i>Off</i>	<i>Disables the heartbeat</i>	
Heartbeat Timeout	DeviceLinkHeartbeatTimeout	Controls the GenCP heartbeat timeout	1.00 Expert
Camera Link Configuration	CIConfiguration	Describes the camera's current Camera Link configuration.	1.00 Beginner
<i>Base</i>	<i>Base</i>	<i>Camera Link Full Configuration allows up to a 24-bit data path or up to 3-tap x 8-bit.</i>	
<i>Full</i>	<i>Full</i>	<i>Camera Link Full Configuration allows up to a 64-bit data path or up to 8-tap x 8-bit.</i>	
<i>Eighty Bit</i>	<i>EightyBit</i>	<i>Camera Link 80-bit Configuration allows up to an 80-bit data path or up to 10-tap x 8-bit.</i>	
Camera Link TimeSlots	CITimeSlotsCount	Displays the number of consecutive time slots required for one complete data transfer of all camera taps. For example, when sending 4 taps over a 2 tap configuration, the required number of timeslots is 2.	1.00 Beginner

<i>One Time Slot</i>	<i>TimeSlots1</i>	<i>One time slot is required for one complete data transfer of all camera taps.</i>	
Camera Link Taps	deviceTapsCount	Number of Camera Link taps in the current configuration.	1.00 Beginner
<i>8</i>	<i>Eight</i>	<i>The data path in this mode uses eight Camera Link Taps per timeslot.</i>	
<i>10</i>	<i>Ten</i>	<i>The data path in this mode uses ten Camera Link Taps per timeslot.</i>	
<i>12</i>	<i>Twelve</i>	<i>The data path in this mode uses twelve Camera Link Taps per timeslot.</i>	
Pixel Size	clPixelSize	Total size in bits of an image pixel. Important: Use this feature to change the camera's output pixel format – if multiple pixel formats are supported.	1.00 Beginner
<i>8 Bits/Pixel</i>	<i>Bpp8</i>	<i>Bpp8: 8 bits per pixel</i>	
<i>10 Bits/Pixel</i>	<i>Bpp10</i>	<i>Bpp10: 10 bits per pixel</i>	
<i>12 Bits/Pixel</i>	<i>Bpp12</i>	<i>Bpp12: 12 bits per pixel</i>	
Camera Link Pixel Clock Frequency	clDeviceClockFrequency	Returns the frequency, in Hz, of the Camera clock.	1.00 Beginner
Camera Tap Geometry	DeviceTapGeometry	The tap geometry describes the geometrical properties characterizing the different taps of a multi-tap camera.	1.00 Beginner
<i>Geometry 1X2 Y1</i>	<i>Geometry_1X2_Y1</i>	<i>2 tap area scan, with 1 zone in X with 2 alternating taps and 1 zone in Y. Tap 1 starts with pixel coordinate (1,1), extending to the image width -1 and height, using a step of 2 (that is x = 1, 3, 5,...). Tap 2 starts with pixel coordinate (2, 1), extending to the image width and height, using a step of 2 (that is, x = 2,4,6, ...).</i>	
<i>Geometry 1X3 Y1</i>	<i>Geometry_1X3_Y1</i>	<i>3 tap area scan, with 1 zone in X with 3 alternating taps and 1 zone in Y. Tap 1 starts with pixel coordinate (1,1), extending to the image width -1 and height, using a step of 3 (that is x = 1, 4, 7,...). Tap 2 starts with pixel coordinate (2, 1), extending to the image width and height, using a step of 3 (that is, x = 2, 5, 8, ...). Firmware available on demand only.</i>	
<i>Geometry 1X8 Y1</i>	<i>Geometry_1X8_Y1</i>	<i>8 tap area scan, with 1 zone in X with 8 alternating taps and 1 zone in Y. Tap 1 starts with pixel coordinate (1,1), extending to the image width -1 and height, using a step of 8 (that is x = 1, 9, 17,...). Tap 2 starts with pixel coordinate (2, 1), extending to the image width and height, using a step of 8 (that is, x = 2, 10, 18, ...)</i>	
<i>Geometry 1X10 Y1</i>	<i>Geometry_1X10_Y1</i>	<i>10 tap area scan, with 1 zone in X with 10 alternating taps and 1 zone in Y. Tap 1 starts with pixel coordinate (1,1), extending to the image width -1 and height, using a step of 10 (that is x = 1, 11, 21,...). Tap 2 starts with pixel coordinate (2, 1), extending to the image width and height, using a step of 10 (that is, x = 2, 12, 22, ...).</i>	
Camera Link Data Valid Mode	clDataValidMode	The Data Valid mode describes if the Data Valid signal from the camera is available to the frame grabber.	1.00 Invisible
<i>Off</i>	<i>Off</i>	<i>The Data Valid signal is not valid and should not be used by the framegrabber for image acquisition.</i>	
<i>Active</i>	<i>Active</i>	<i>The Data Valid signal is valid and should be used by the framegrabber for image acquisition.</i>	

Payload Size	PayloadSize	Provides the number of bytes transferred for each image or chunk on the stream channel.	1.00 Invisible
--------------	-------------	---	-------------------

File Access Control Category

The File Access control in CamExpert allows the user to quickly upload various data files to the connected Genie Nano. The supported data files are for firmware updates, and dependent on the Nano model, LUT tables, Defective Pixel Maps, and other Sapera file types.

Features listed in the description table but tagged as *Invisible* are usually for Teledyne DALSA or third party software usage—not typically needed by end user applications.

Also important, Genie Nano cameras are available in a number of models implementing different sensors and image resolutions which may not support the full feature set defined in this category.

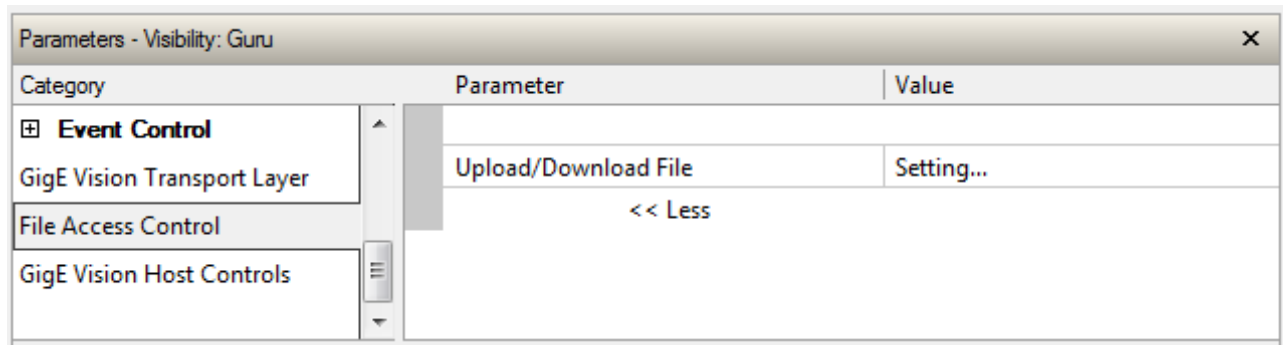

File Access Control Feature Descriptions

The Device Version number represents the camera software functional group, not a firmware revision number. As Genie Nano capabilities evolve the device version tag will increase, therefore identifying the supported function package. New features for a major device version release will be indicated by **green text** for easy identification.

Display Name	Feature & Values	Description	Device Version & View
File Selector	FileSelector	Selects the file to access. The file types which are accessible are device-dependent.	1.00 Guru
<i>Firmware</i>	<i>Firmware1</i>	<i>Upload new firmware to the camera which will execute on the next camera reboot cycle. Select the DeviceReset feature after the upload completes.</i>	
<i>Factory Defective Pixel Map</i>	<i>BadPixelCoordinate0</i>	<i>Select the Factory Defective Pixel Map.</i>	
<i>User Defective Pixel Map</i>	<i>BadPixelCoordinate1</i>	<i>Select the User Defective Pixel Map XML file as defined in Advanced Processing.</i>	
<i>Factory Flat Line coefficients 1</i>	<i>FlatFieldCoefficients01</i>	<i>Select factory Flat Line coefficients 1. These are the factory values used when the camera fastReadoutMode is Off and sensor Gain is 1.0.</i>	

Factory Flat Line coefficients 2	FlatFieldCoefficients02	Select factory Flat Line coefficients 2. These are the factory values used when the camera fastReadoutMode is Off and sensor Gain is 1.26.	
Factory Flat Line coefficients 3	FlatFieldCoefficients03	Select factory Flat Line coefficients 3. These are the factory values used when the camera fastReadoutMode is Off and sensor Gain is 1.87.	
Factory Flat Line coefficients 4	FlatFieldCoefficients04	Select factory Flat Line coefficients 4. These are the factory values used when the camera fastReadoutMode is Off and sensor Gain is 3.17.	
Factory Flat Line coefficients 5	FlatFieldCoefficients05	Select factory Flat Line coefficients 5. These are the factory values used when the camera fastReadoutMode is Active and sensor Gain is 1.0.	
Factory Flat Line coefficients 6	FlatFieldCoefficients06	Select factory Flat Line coefficients 6. These are the factory values used when the camera fastReadoutMode is Active and sensor Gain is 1.26.	
Factory Flat Line coefficients 7	FlatFieldCoefficients07	Select factory Flat Line coefficients 7. These are the factory values used when the camera fastReadoutMode is Active and sensor Gain is 1.87.	
Factory Flat Line coefficients 8	FlatFieldCoefficients08	Select factory Flat Line coefficients 8. These are the factory values used when the camera fastReadoutMode is Active and sensor Gain is 3.17.	
User Flat Line coefficients 1	FlatFieldCoefficients1	Select user Flat Line coefficients 1. These are the coefficient values used when the sensor analog Gain is 1.0.	
User Flat Line coefficients 2	FlatFieldCoefficients2	Select user Flat Line coefficients 2. These are the coefficient values used when the sensor Gain is 1.26.	
User Flat Line coefficients 3	FlatFieldCoefficients3	Select user Flat Line coefficients 3. These are the coefficient values used when the sensor Gain is 1.87.	
User Flat Line coefficients 4	FlatFieldCoefficients4	Select user Flat Line coefficients 4. These are the coefficient values used when the sensor Gain is 3.17.	
Lens Shading Correction 1	LensShadingCorrection1	Lens Shading coefficients set 1	
Lens Shading Correction 2	LensShadingCorrection2	Lens Shading coefficients set 2	
User Defined Saved Image	userDefinedSavedImage	Upload and download an image in the camera.	
File Operation Selector	FileOperationSelector	Selects the target operation for the selected file in the device. This operation is executed when the File Operation Execute feature is called.	1.00 Guru
Open	Open	Select the Open operation – executed by FileOperationExecute.	
Close	Close	Select the Close operation – executed by FileOperationExecute	
Read	Read	Select the Read operation – executed by FileOperationExecute.	
Write	Write	Select the Write operation – executed by FileOperationExecute.	
Delete	Delete	Select the Delete operation – executed by FileOperationExecute.	
File Operation Execute	FileOperationExecute	Executes the operation selected by File Operation Selector on the selected file.	1.00 Guru
File Open Mode	FileOpenMode	Selects the access mode used to open a file on the device.	1.00 Guru
Read	Read	Select READ only open mode	
Write	Write	Select WRITE only open mode	
File Access Buffer	FileAccessBuffer	Defines the intermediate access buffer that allows the exchange of data between the device file storage and the application.	1.00 Guru

File Access Offset	FileAccessOffset	Controls the mapping offset between the devices file storage and the file access buffer.	1.00 Guru
File Access Length	FileAccessLength	Controls the mapping length between the device file storage and the file access buffer.	1.00 Guru
File Operation Status	FileOperationStatus	Displays the file operation execution status.	1.00 Guru
<i>Success</i>	<i>Success</i>	<i>The last file operation has completed successfully.</i>	
<i>Failure</i>	<i>Failure</i>	<i>The last file operation has completed unsuccessfully for an unknown reason.</i>	
<i>File Unavailable</i>	<i>FileUnavailable</i>	<i>The last file operation has completed unsuccessfully because the file is currently unavailable.</i>	
<i>File Invalid</i>	<i>FileInvalid</i>	<i>The last file operation has completed unsuccessfully because the selected file is not present in this camera model.</i>	
File Operation Result	FileOperationResult	Displays the file operation result. For Read or Write operations, the number of successfully read/written bytes is returned.	1.00 Guru
File Size	FileSize	Represents the size of the selected file in bytes.	1.00 Guru
Device User Buffer	deviceUserBuffer	Unallocated memory available to the user for data storage.	1.00 DFNC Invisible
User Defined Saved Image Max Size	userDefinedSavedImageMaxSize	Maximum size of the user Defined Saved Image in the flash memory.	1.00 DFNC Invisible
Save Last Image to Flash	saveLastImageToFlash	Command that saves the last acquired image to camera flash memory. Use the file transfer feature to read the image from camera.	1.00 DFNC Invisible

Updating Firmware via File Access in CamExpert

- Click on the “Setting...” button to show the file selection menu.

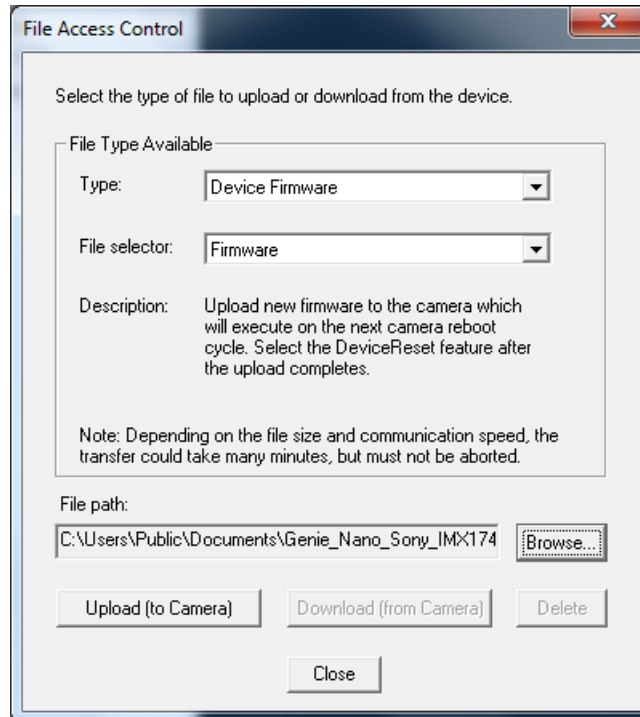

- From the **File Type** drop menu, select the file **Type** that will be uploaded to the Genie Nano. This CamExpert tool allows quick firmware changes or updates, when available for your Genie Nano model.
- From the **File Selector** drop menu, select the Genie Nano memory location for the uploaded data. This menu presents only the applicable data locations for the selected file type.
- Click the Browse button to open a typical Windows Explorer window.
- Select the specific file from the system drive or from a network location.
- Click the Upload button to execute the file transfer to the Genie Nano.
- Reset the Nano when prompted.

Overview of the *deviceUserBuffer* Feature

The feature *deviceUserBuffer* allows the machine vision system supplier access to 4 kB of reserved flash memory within the Genie Nano. This memory is available to store any data required, such as licensing codes, system configuration codes, etc. as per the needs of the system supplier. No Nano firmware operation will overwrite this memory block thus allowing and simplifying product tracking and control.

Transfer Control Category

The Transfer control features are all invisible. These features are usually for Teledyne DALSA or third party software usage—not typically needed by end user applications.

Transfer Control Feature Descriptions

The Device Version number represents the camera software functional group, not a firmware revision number. As Nano-CL capabilities evolve the device version tag will increase, therefore identifying the supported function package. New features for a major device version release will be indicated by **green text** for easy identification.

Display Name	Feature & Values	Description	Device Version & View
Device Registers Streaming Start	DeviceRegistersStreamingStart	Announces the start of registers streaming without immediate checking for consistency.	1.00 Invisible
Device Registers Streaming End	DeviceRegistersStreamingEnd	Announces end of registers streaming and performs validation for registers consistency before activating them.	1.00 Invisible
Device Feature Streaming Start	DeviceFeaturePersistenceStart	Announces the start of feature streaming without immediate checking for consistency.	1.00 Invisible
Device Feature Streaming End	DeviceFeaturePersistenceEnd	Announces end of feature streaming and performs validation for feature consistency before activating them.	1.00 Invisible
Register Check	DeviceRegistersCheck	Performs an explicit register set validation for consistency.	1.00 Invisible
Registers Valid	DeviceRegistersValid	States if the current register set is valid and consistent.	1.00 Invisible

GenICamAccess Control Feature

Display Name	Feature & Values	Description	Device Version & View
Features Locked Flag	TLParamsLocked	Flag to indicate if features are locked during acquisition.	1.00 Invisible

Implementing Trigger-to-Image Reliability

Overview

In a complex imaging system a lot can go wrong at all points – from initial acquisition, to camera processing, to data transmission. Teledyne DALSA provides features, events, and I/O signals that provide the system designer with the tools to qualify the system in real time.

The Teledyne DALSA website provides general information, FAQ, and White Paper download about the Trigger-to-Image Reliability (T2IR) framework in hardware and Sopera LT software SDK. <http://www.teledynedalsa.com/imaging/knowledge-center/appnotes/t2ir/>

T2IR with Genie Nano

Nano provides a number of features for system monitoring:

- Built-in Self-Test on power-up and reset after firmware change
- Internal Temperature Reporting
- In Camera Event Status Flags
 - Invalid External Trigger
 - Image Lost

Nano Features for T2IR Monitoring

The following table presents some of the Nano camera features a developer can use for T2IR monitoring. The output line signals would interface to other external devices.

Camera Status Monitoring	
Device Built-In Self Test	deviceBIST
Device Built-In Self Test Status	deviceBISTStatus
Device Temperature Selector	DeviceTemperatureSelector
Device Version	DeviceVersion
Firmware Version	DeviceFirmwareVersion
Last firmware update failed	FirmwareUpdateFailure
Manufacturer Part Number	deviceManufacturerPartNumber
Manufacturer Info	DeviceManufacturerInfo
Events	
Event Selector	EventSelector
Event Notification	EventNotification
Event Statistic Selector	eventStatisticSelector
Event Statistic Count	eventStatisticCount
Events Overflow	eventsOverflow
Event Statistic Count Reset	eventStatisticCountReset
Acquisition and Triggers	
Valid Frame Trigger	ValidFrameTrigger
Invalid Frame Trigger	InvalidFrameTrigger
Image Lost	ImageLost

Technical Specifications

Both 2D and 3D design drawings are available for download from the Teledyne DALSA web site [<http://www.teledynedalsa.com/genie-nano>].

Notes on Genie Nano Identification and Mechanical

Identification Label

	<p>Genie Nano cameras have an identification label applied to the bottom side, with the following information:</p> <ul style="list-style-type: none">Model Part NumberSerial number2D BarcodeCE and FCC logo
---	---

Additional Mechanical Notes

	<p>For information on Nano lens requirements see Optical Considerations. Each camera side has two mounting holes in identical locations, which provide good grounding capabilities. Overall height or width tolerance is $\pm 0.05\text{mm}$.</p>
---	--

Temperature Management

Genie Nano cameras are designed to optimally transfer internal component heat to the outer metallic body. If the camera is free standing (i.e. not mounted) it will be very warm to the touch.

Basic heat management is achieved by mounting the camera onto a metal structure via its mounting screw holes. Heat dissipation is improved by using thermal paste between the camera body (not the front plate) and the metal structure.

Mechanical Specifications — Nano-CL Medium Case:

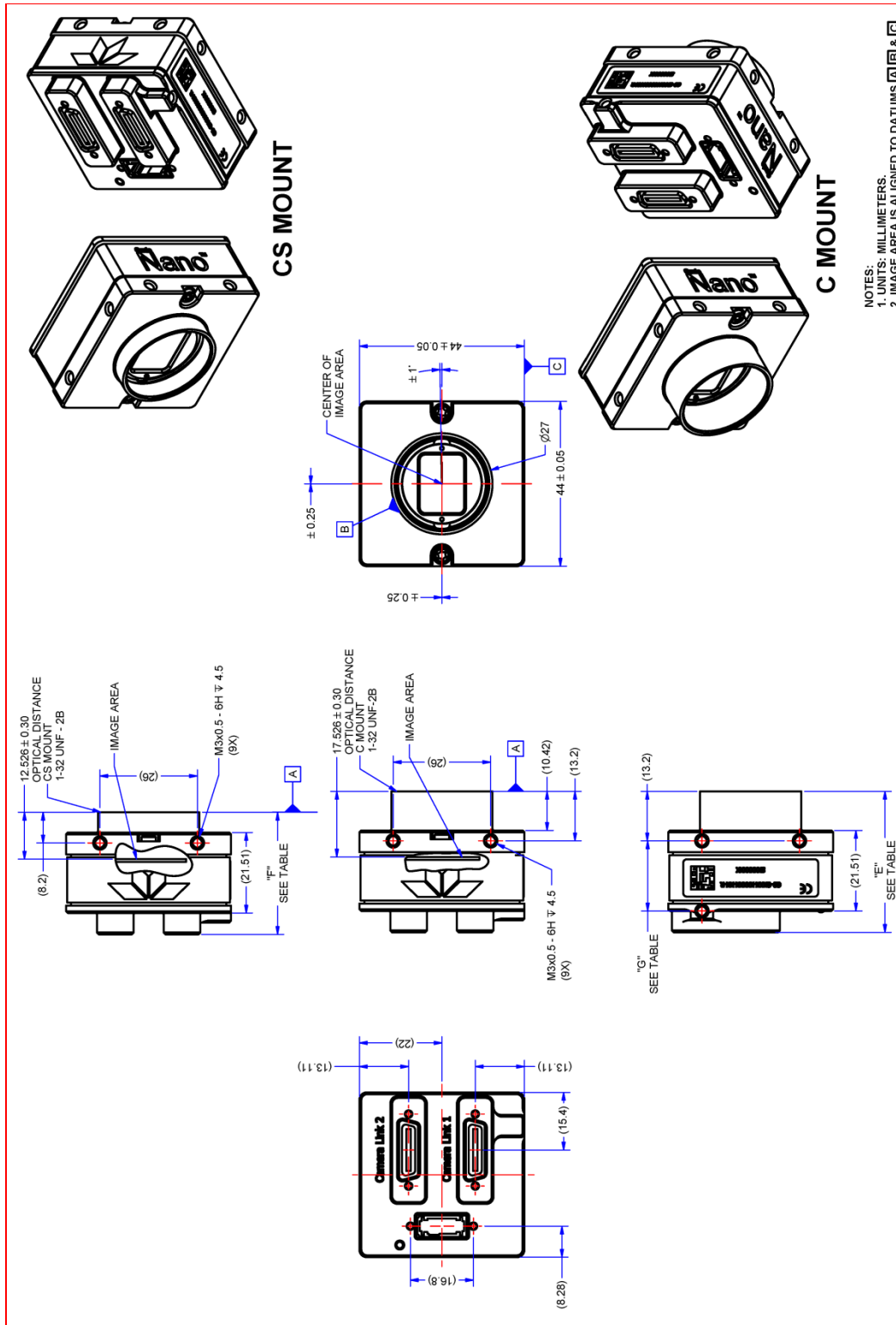

Note: Genie Nano-CL with C or CS Mount

Mechanical Specifications — Nano-CL XL Case:

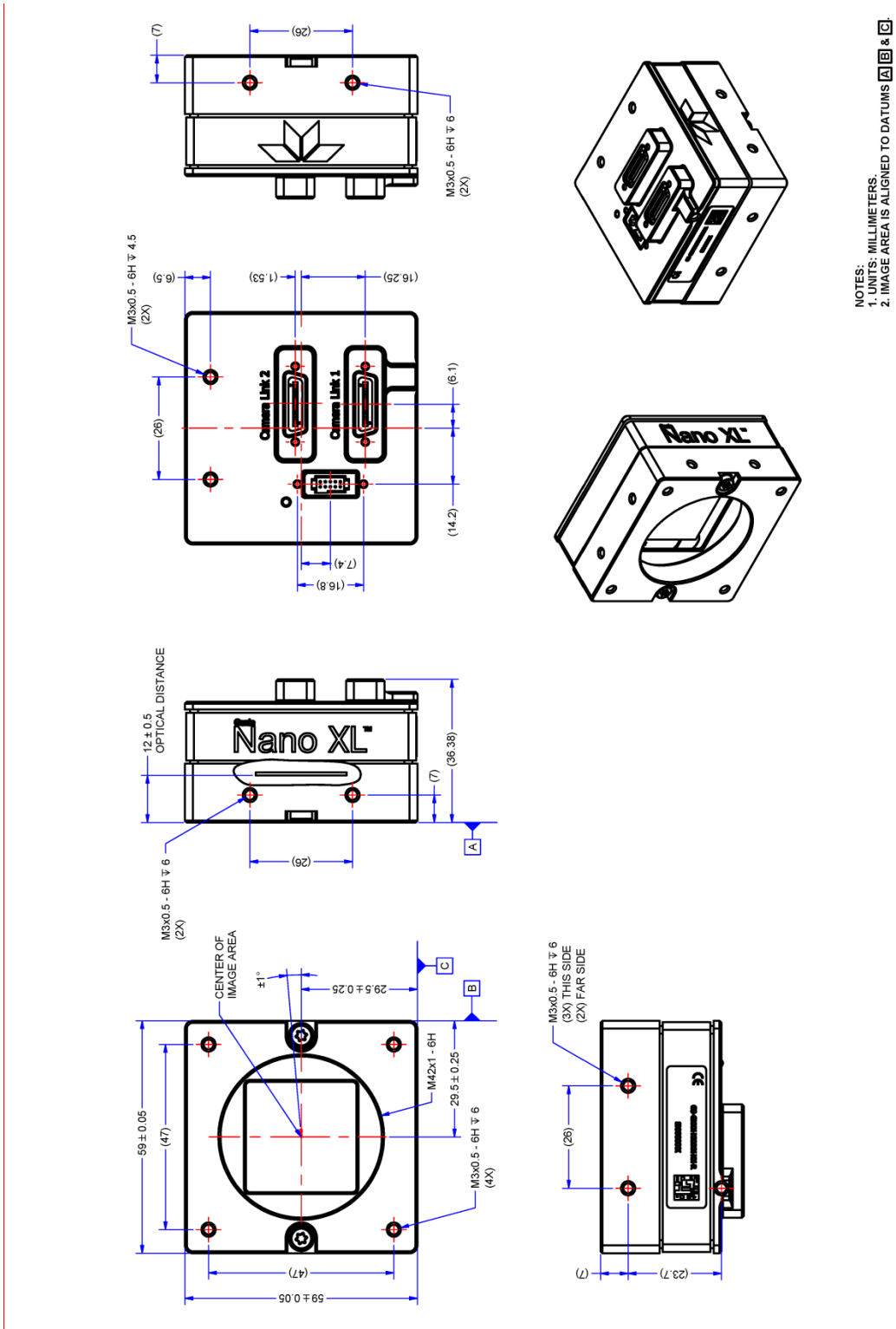

NOTES:
 1. UNITS: MILLIMETERS.
 2. IMAGE AREA IS ALIGNED TO DATUMS A, B & C

Note: Genie Nano-CL with M42 Mount

Sensor Alignment Specification

The following figure specifies sensor alignment for Genie Nano where all specifications define the absolute maximum tolerance allowed for production cameras. Dimensions "x, y, z", are in microns and referenced to the Genie Nano mechanical body or the optical focal plane (for the z-axis dimension). Theta specifies the sensor rotation relative to the sensor's center and Nano mechanical.

X variance	+/- 250 microns	<div style="text-align: center;"> <p>Sensor Alignment Reference</p> <p>The diagram shows a square sensor centered within a circle. A vertical dashed line represents the Z-axis, with a double-headed arrow labeled '(+) Z variance not shown'. A horizontal dashed line represents the X-axis, with a double-headed arrow labeled '(+) X variance'. A vertical double-headed arrow to the left of the circle is labeled '(+) Y variance'. A vertical dashed line with a double-headed arrow at the top is labeled '(+) theta variance'.</p> </div>
Y variance	+/- 250 microns	
Z variance	+/- 300 microns	
Theta variance	+/- 1 degree	

I/O Connector and Pinout

- An auxiliary DC power source can be connected to the 10-pin connector (SAMTEC TFM-105-02-L-D-WT) when not using a PoCL power source. Nano supports connecting cables with retention latches or screw locks. The following figure shows the pin number assignment.
- Note: Connect power via the I/O or PoCL, but never both. Although Nano has protection, differences in ground levels may cause operational issues or electrical faults.

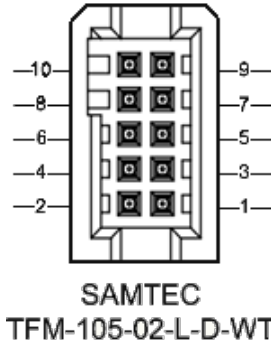

10-pin I/O Connector Pinout Details

Teledyne DALSA makes available optional I/O cables as described in Accessories. Contact Sales for availability and pricing.

Pin Number	Genie Nano	Direction	Definition
1	PWR-GND	—	Camera Power Ground (common with chassis pin10)
2	PWR-VCC	—	Camera Power – DC +10 to +36 Volts
3 - 9	N/A	—	Reserved
10	Chassis	—	Camera Chassis (connected to camera link connector shell & pin-1)

Camera DC Power Characteristics

DC Operating Characteristics		
Input Voltage	+10 Volts minimum	
Input Power Consumption	@ +24 Volt Supply	7 Watts typical (using 10-Taps)

Absolute Maximum DC Power Supply Range before Possible Device Failure		
Input Voltage	-58 Volt DC	+58 Volts DC

I/O Mating Connector Specifications & Sources

For users wishing to build their own custom I/O cabling, the following product information is provided to expedite your cable solutions. SAMTEC web information for the discrete connector and a cable assembly with retention clips follows the table.

MFG	Part #	Description	Data Sheet
Samtec	ISDF-05-D ISDF-05-D-M (see image below)	Discrete Connector (see example below)	https://www.samtec.com/products/isdf
Samtec	SFSD-05-[WG]-G-[AL]-DR-[E2O] WG : Wire Gauge AL : Assembled Length E2O : End 2 Option	Discrete Cable Assembly (see example below)	https://www.samtec.com/products/sfsd
ISDF-05-D-M Connector Availability On-Line			
North-America (specific country can be selected)		http://www.newark.com/samtec/isdf-05-d-m/connector-housing-receptacle-10/dp/06R6184	
Europe (specific country can be selected)		http://uk.farnell.com/samtec/isdf-05-d-m/receptacle-1-27mm-crimp-10way/dp/2308547?ost=ISDF-05-D-M	
Asia-Pacific (specific country can be selected)		http://sg.element14.com/samtec/isdf-05-d-m/receptacle-1-27mm-crimp-10way/dp/2308547?ost=ISDF-05-D-M	
Important: Samtec ISDF-05-D-S is not compatible with Genie Nano			

Samtec ISDF-05-D-M mating connector for customer built cables w/retention clips “.050” Tiger Eye™ Discrete Wire Socket Housing”

ISDF-05-D-M

Description	Value
Series	ISDF
No. of Positions	-05
Row	-D - Double Row
End Options	-M - Metal Retention L
Part Number	ISDF-05-D-M

3D Preview
2D View
Download
Help

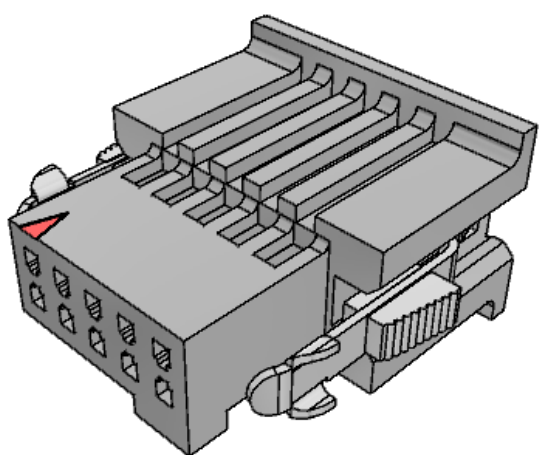

**Samtec connector-cable assembly SFSD-05-28-H-03.00-SR w/retention clips
 “.050” Tiger Eye™ Double Row Discrete Wire Cable Assembly, Socket”**

SFSD-05-28-H-03.00-SR	
Description	Value
Series	SFSD
No. of Positions	-05
Wire Gauge	-28 AWG
Wire Color Code	All Black Wire
Plating Options	-H - 30µ Heavy Gold
Assembly Length	3.00 INCH
End Option	-SR - Single Ended wit
Notch Option	Not Available
Part Number	SFSD-05-28-H-03.00-SR
Cable Type Option	PVC Cable

3D Preview
2D View
Download
Help

Power over Camera Link (PoCL) Support



- The Nano-CL supports PoCL electrical power delivered from a PoCL capable frame grabber if not using a separate external power source connected to pins 1 & 2 of the camera’s I/O Connector.
- When using PoCL, ensure the camera link cables are certified for PoCL usage.
- PoCL requires that the camera be connected with both cables to the frame grabber.
- **Important:** Connect power via the I/O connector or PoCL, but not both. Although Nano-CL has protection, differences in ground levels may cause operational issues or electrical faults.
- If both supplies are connected and active, the Nano-CL will use the I/O power supply connector. But as stated, ground differences may cause camera faults or failure.

EC & FCC Declarations of Conformity

Models M/C2420, M/C4020, M/C2450, M/C4040, M/C4060



EMC DECLARATION OF CONFORMITY

We :
Teledyne DALSA, a business unit of Teledyne Digital Imaging, Inc.
880 Rue McCaffrey
St-Laurent, Quebec, Canada
H4T 2C7

Declare under sole legal responsibility that the following products conform to the protection requirements of council directive 2014/30/EU on the approximation of the laws of member states relating to electromagnetic compatibility and are CE-marked accordingly:

Genie Nano-CL M2420, C2420, M4020, C4020,
M2450, C2450, M4040, C4040, M4060 & C4060

The products to which this declaration relates are in conformity with the following relevant harmonized standards, the reference numbers of which have been published in the Official Journal of the European Communities:

EN55032 (2015)	Electromagnetic compatibility of multimedia equipment — Emission requirements
EN55011 (2016) with A1(2017)	Industrial, scientific and medical equipment — Radio-frequency disturbance characteristics — Limits and methods of measurement
EN 61326-1 (2013)	Electrical equipment for measurement, control and laboratory use — EMC requirements — Part 1: General requirements
EN 55024 (2010)	Information technology equipment — Immunity characteristics — Limits and methods of measurement
EN 55035 (2017)	Electromagnetic compatibility of multimedia equipment – Immunity requirements

Further declare under our sole legal responsibility that the product listed also conforms to the following international standards:

CFR 47	part 15 (2008), subpart B, for a class A product. Limits for digital devices
ICES-003	Information Technology Equipment (ITE) — Limits and Methods of Measurement
CISPR 11(2015) with A1 (2016)	Industrial, scientific and medical equipment - Radio-frequency disturbance characteristics - Limits and methods of measurement
CISPR 32 (2015)	Electromagnetic compatibility of multimedia equipment - Emission requirements
CISPR 35 (2016)	Electromagnetic compatibility of multimedia equipment - Immunity requirements

Note: this product is intended to be a component of a larger industrial system. It is not intended for use in a residential system.

Waterloo, Canada
Location

2019-07-24
Date

Cheewee Tng, P. Eng
Director, Quality Assurance

THIS IS AN UNCONTROLLED COPY OF A CONTROLLED DOCUMENT PRINTED 9/5/2019 4:43 PM
The information contained herein is proprietary to TELEDYNE DALSA and is to be used solely for the purpose for which it is supplied. It shall not be disclosed in whole or in part, to any other party, without the express permission in writing by TELEDYNE DALSA. In addition, as of the last revision date, the information contained in this document is not subject to Export Control in Canada

Models M/C5100, M/C4090



EMC DECLARATION OF CONFORMITY

We:
 Teledyne DALSA, a business unit of Teledyne Digital Imaging, Inc.
 880 Rue McCaffrey
 St-Laurent, Quebec, Canada
 H4T 2C7

Declare under sole legal responsibility that the following products conform to the protection requirements of council directive 2014/30/EU on the approximation of the laws of member states relating to electromagnetic compatibility and are CE-marked accordingly:

Genie Nano-CL M5100, M4090
Genie Nano-CL C5100, C4090

The products to which this declaration relates are in conformity with the following relevant harmonized standards, the reference numbers of which have been published in the Official Journal of the European Communities:

EN55032 (2015)	Electromagnetic compatibility of multimedia equipment — Emission requirements
EN55011 (2016) with A1(2017)	Industrial, scientific and medical equipment — Radio-frequency disturbance characteristics — Limits and methods of measurement
EN 61326-1 (2013)	Electrical equipment for measurement, control and laboratory use — EMC requirements — Part 1: General requirements
EN 55024 (2010)	Information technology equipment — Immunity characteristics — Limits and methods of measurement
EN 55035 (2017)	Electromagnetic compatibility of multimedia equipment – Immunity requirements

Further declare under our sole legal responsibility that the product listed also conforms to the following international standards:

CFR 47	part 15 (2008), subpart B, for a class A product. Limits for digital devices
ICES-003	Information Technology Equipment (ITE)—Limits and Methods of Measurement
CISPR 11(2015) with A1(2016)	Industrial, scientific and medical equipment - Radio-frequency disturbance characteristics - Limits and methods of measurement
CISPR 32 (2015)	Electromagnetic compatibility of multimedia equipment - Emission requirements
CISPR 35 (2016)	Electromagnetic compatibility of multimedia equipment - Immunity requirements

Note: this product is intended to be a component of a larger industrial system. It is not intended for use in a residential system.

Waterloo, Canada
 Location

2019-04-24
 Date

Cheewee Tng, P. Eng
 Director, Quality Assurance

****THIS IS AN UNCONTROLLED COPY OF A CONTROLLED DOCUMENT PRINTED 5/27/2019 10:08 AM****
 The information contained herein is proprietary to TELEDYNE DALSA and is to be used solely for the purpose for which it is supplied. It shall not be disclosed in whole or in part, to any other party, without the express permission in writing by TELEDYNE DALSA. In addition, as of the last revision date, the information contained in this document is not subject to Export Control in Canada

Additional Reference Information

Choosing a Lens with the Correct Image Circle

Each Nano model requires a lens with an image circle specification to fully illuminate the sensor. The following section graphically shows the minimum lens image circle for each Nano model family along with alternative lens types. Brief information on other lens parameters to consider follows those sections.

Lens Options for Models '2450'

- The following figure shows the lens image circles relative to Genie Nano models using the Sony IMX250 sensor, in color or monochrome versions.
- A typical 2/3" lens will fully illuminate this sensor.

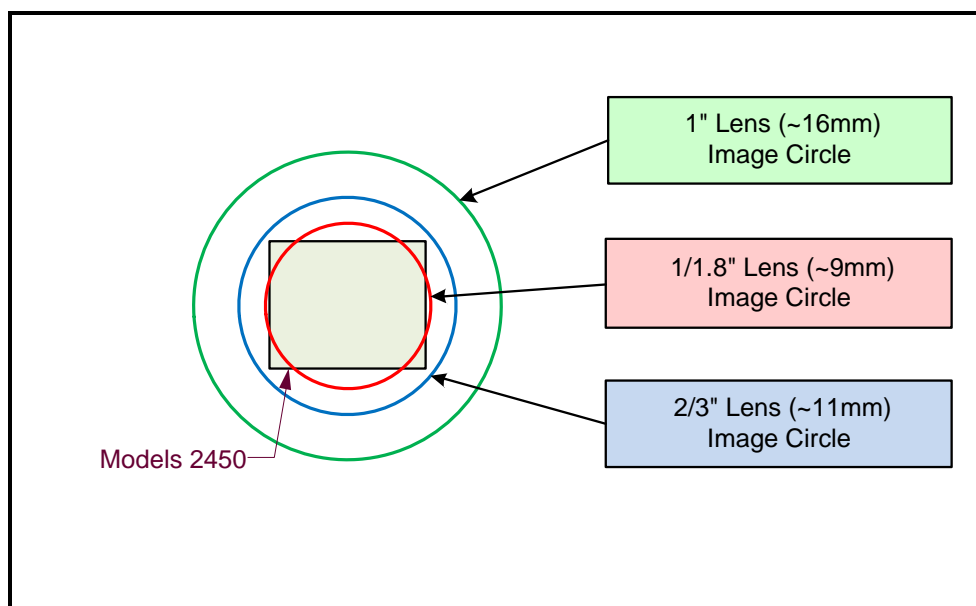

Lens Options for Models '4060/4040'

- The following figure shows the lens image circles relative to Genie Nano models using the Sony IMX255 (models 4060), IMX253 (models 4040) sensors.
- A typical 1.1" lens will illuminate the model 4040 sensors models while the 1" lens should only be used with models 4060 to avoid image vignetting.

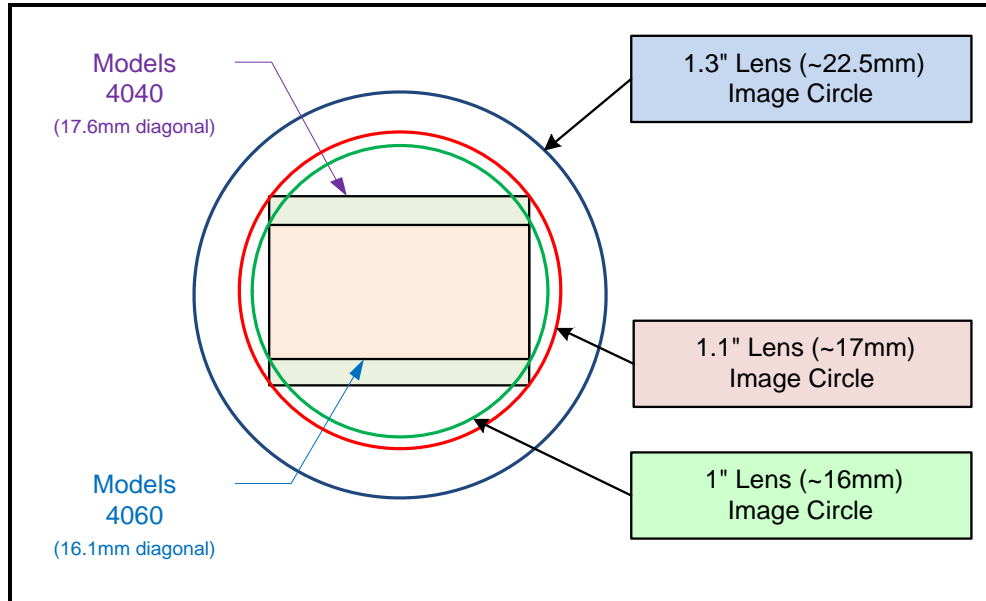

Lens Options for CL Models 'M/C 5100' and 'M/C 4090'

- The following figure shows the lens image circles relative to Genie Nano-CL models using the OnSemi Python 25K and Python 16K sensors.
- These Nano-CL models have a M42 screw mount where M42 lens or F-mount lens (via an adapter) need to have image circles exceeding the diameter of either of these larger sensors.

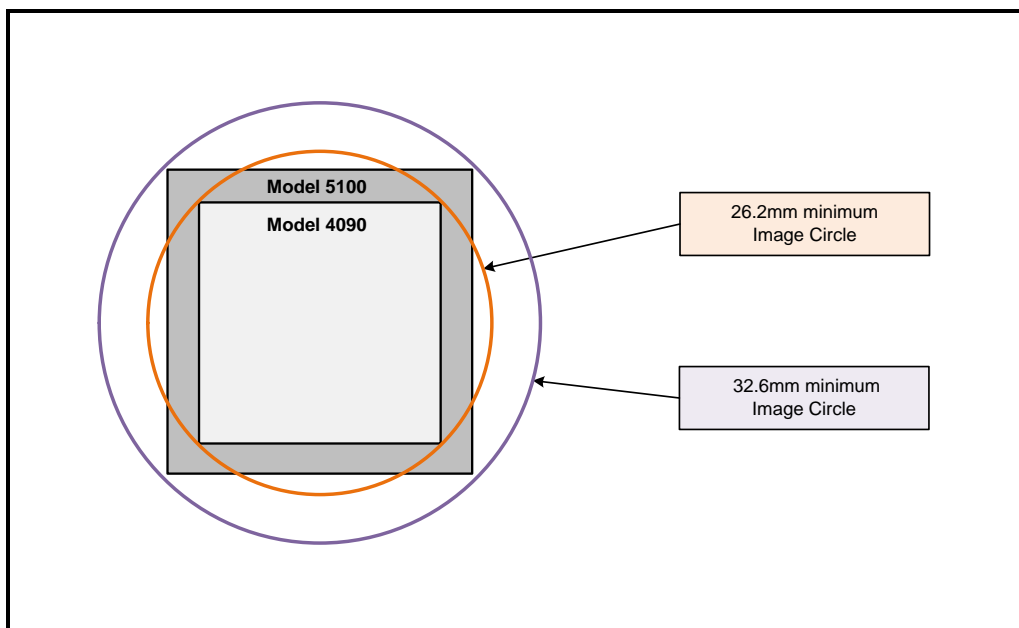

Additional Lens Parameters (application specific)

There are other lens parameters that are chosen to meet the needs of the vision application. These parameters are independent of the Nano model (assuming that the Lens Mount and Lens Sensor Size parameters are correct, as previously covered in this section). A vision system integrator or lens specialist should be consulted when choosing lenses since there is a trade-off between the best lenses and cost. An abridged list of lens parameters follows – all of which need to be matched to the application.

- **Focal Length:** Defines the focus point of light from infinity. This parameter is related to the Nano mount (C or CS mount). See Genie Nano Specifications — Back Focal Distance.
- **Field of View:** A lens is designed to image objects at some limited distance range, at some positive or negative magnification. This defines the field of view.
- **F-Number (aperture):** The lens aperture defines the amount of light that can pass. Lenses may have fixed or variable apertures. Additionally the lens aperture affects Depth of Field which defines the distance range which is in focus when the lens is focus at some specific distance.
- **Image Resolution and Distortion:** A general definition of image quality. A lens with poor resolution seems to never be in focus when used to image fine details.
- **Aberrations (defect, chromatic, spherical):** Aberrations are specific types of lens faults affecting resolution and distortion. Lens surface defects or glass faults distort all light or specific colors. Aberrations are typically more visible when imaging fine details.
- **Spatial Distortions:** Describes non-linear lens distortions across the field of view. Such distortion limits the accuracy of measurements made with that lens.

Optical Considerations

This section provides an overview to illumination, light sources, filters, lens modeling, and lens magnification. Each of these components contribute to the successful design of an imaging solution.

Illumination

The amount and wavelengths of light required to capture useful images depend on the particular application. Factors include the nature, speed, and spectral characteristics of objects being imaged, exposure times, light source characteristics, environmental and acquisition system specifics, and more. The Teledyne DALSA Web site, <http://mv.dalsa.com/>, provides an introduction to this potentially complicated issue. Click on Knowledge Center and then select Application Notes and Technology Primers. Review the sections of interest.

It is often more important to consider exposure than illumination. The total amount of energy (which is related to the total number of photons reaching the sensor) is more important than the rate at which it arrives. For example, $5\mu\text{J}/\text{cm}^2$ can be achieved by exposing $5\text{mW}/\text{cm}^2$ for 1ms just the same as exposing an intensity of $5\text{W}/\text{cm}^2$ for $1\mu\text{s}$.

Light Sources

Keep these guidelines in mind when selecting and setting up light source:

- LED light sources are relatively inexpensive, provide a uniform field, and longer life span compared to other light sources. However, they also require a camera with excellent sensitivity.
- Halogen light sources generally provide very little blue relative to infrared light (IR).
- Fiber-optic light distribution systems generally transmit very little blue relative to IR.
- Some light sources age such that over their life span they produce less light. This aging may not be uniform—a light source may produce progressively less light in some areas of the spectrum but not others.

IR Cut-off Filters

Genie Nano cameras are responsive to near infrared (IR) wavelengths. To prevent infrared from distorting the color balance of visible light acquisitions, use a “hot mirror” or IR cut-off filter that transmits visible wavelengths but does not transmit near infrared wavelengths and above.

Genie Nano color cameras have a spectral response that extends into near IR wavelengths (as defined for each sensor model in the sensor specification descriptions). Images captured will have washed out color if the sensor response is not limited to the visible light band.

Nano Models with Built-in IR Cut-off Filters

Choose Nano color cameras with built-in IR Cut-off Filters for an optimized solution. The following graphic shows these models having an IR filter with a specified cut-off of about 646nm.

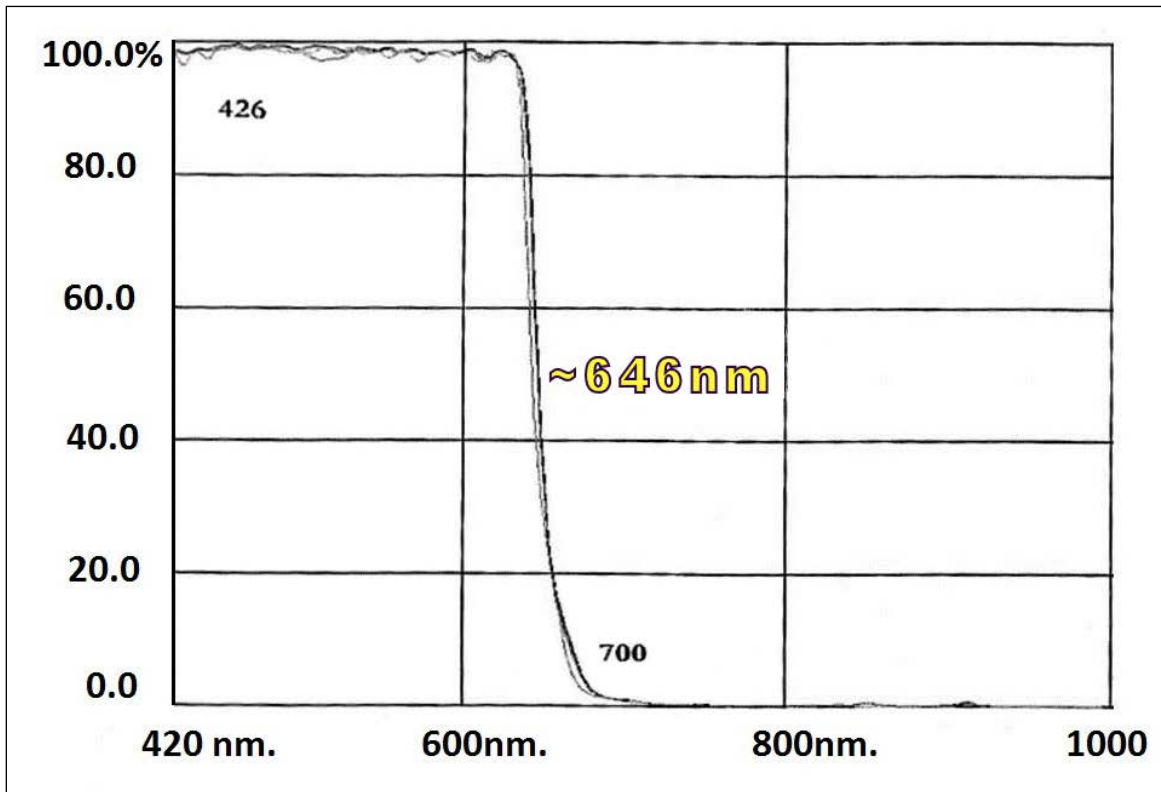

Guidelines for Choosing IR Cut-off Filters

The following graphic, using a color sensor response spectrum, shows the transmission response of typical filters designed for CMOS sensor cameras. When selecting an IR cut-off filter, choose a near infrared blocking specification of ~650nm. Filters that block at 700nm or longer wavelengths, designed for CCD cameras, are not recommended for Genie Nano color cameras.

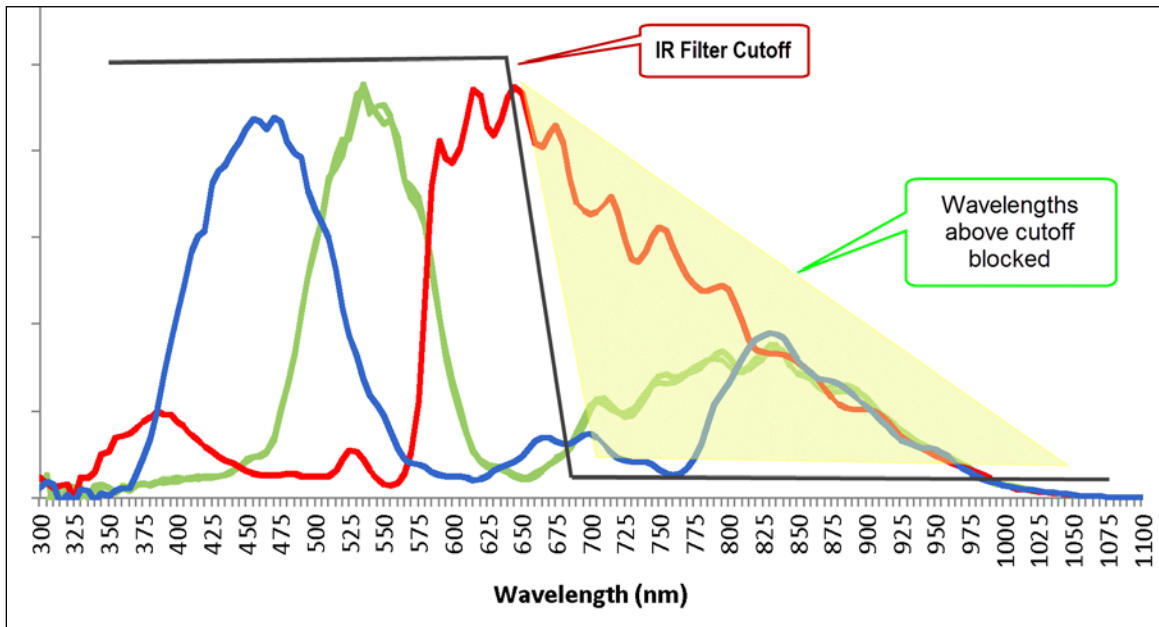

Back Focal Variance when using any Filter

Inserting a filter between a lens and sensor changes the back focal point of the lens used. A variable focus lens simply needs to be adjusted, but in the case of a fixed focus lens, the changed focal point needs correction.

The following simplified illustration describes this but omits any discussion of the Optics, Physics, and the math behind the refraction of light through glass filter media.

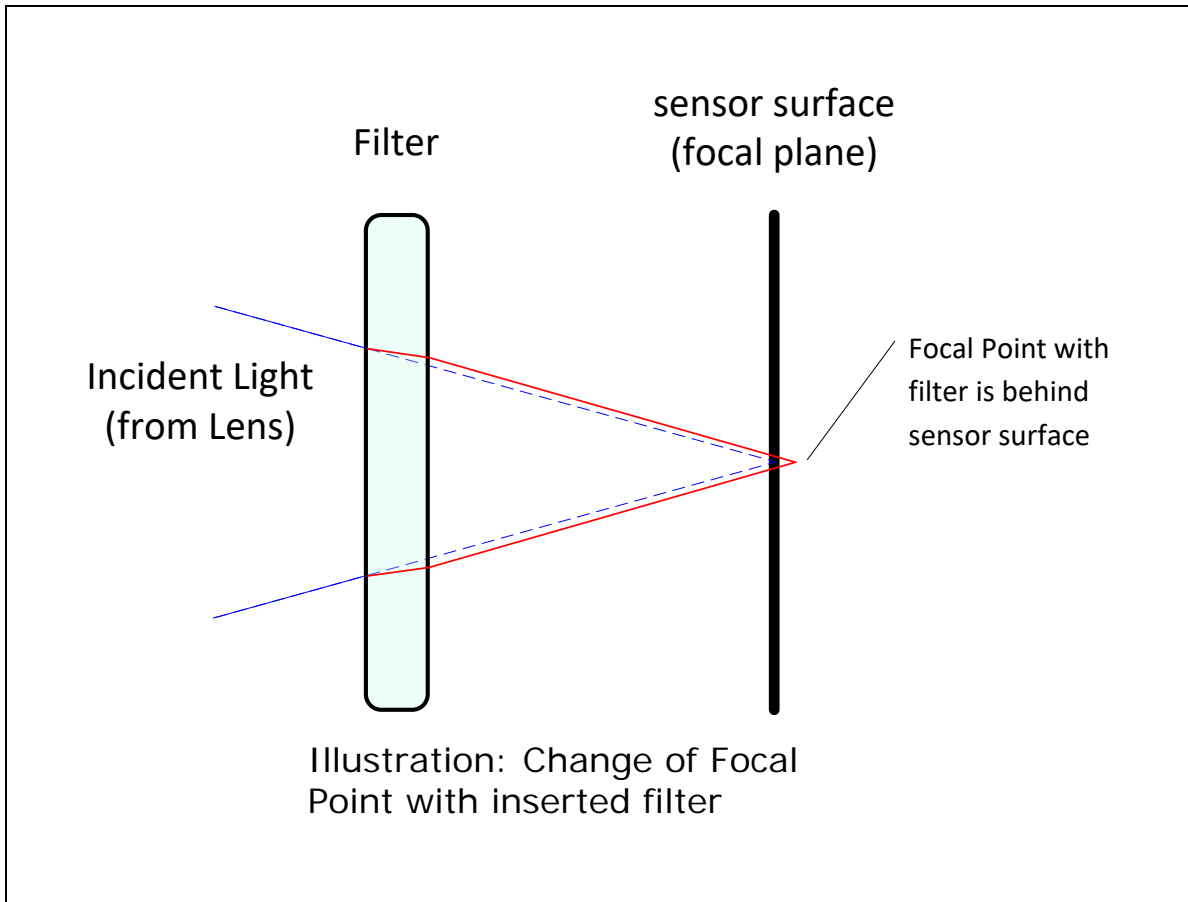

In this example when a glass filter is inserted between the lens and the camera sensor, the focal point is now about 1/3 of the filter thickness behind the sensor plane. Genie Nano filters are specified as 1mm thick.

Genie Nano models with factory installed filters automatically compensate for the focal point variance by having the sensor PCB mounted deeper within the camera body.

For Nano models normally shipped without filters, when a filter is installed a fixed focus lens requires a 1/3mm C-mount shim (spacer) added to move the lens focal point back to the sensor surface. Such shims are available from filter and lens suppliers. Alternatively use a variable focus lens and secure its focus ring after adjustment.

Lens Modeling

Any lens surrounded by air can be modeled for camera purposes using three primary points: the first and second principal points and the second focal point. The primary points for a lens should be available from the lens data sheet or from the lens manufacturer. Primed quantities denote characteristics of the image side of the lens. That is, h is the object height and h' is the image height.

The focal point is the point at which the image of an infinitely distant object is brought to focus. The effective focal length (f') is the distance from the second principal point to the second focal point. The back focal length (BFL) is the distance from the image side of the lens surface to the second focal point. The object distance (OD) is the distance from the first principal point to the object.

Primary Points in a Lens System

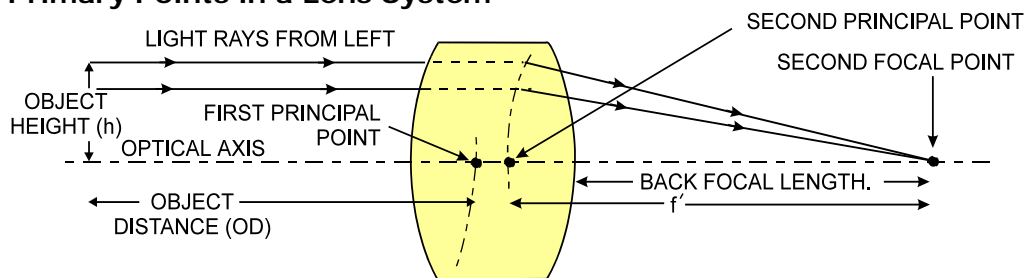

Magnification and Resolution

The magnification of a lens is the ratio of the image size to the object size:

$m = \frac{h'}{h}$	Where m is the magnification, h' is the image height (pixel size) and h is the object height (desired object resolution size).
--------------------	--

By similar triangles, the magnification is alternatively given by:

$m = \frac{f'}{OD}$

These equations can be combined to give their most useful form:

$\frac{h'}{h} = \frac{f'}{OD}$	This is the governing equation for many object and image plane parameters.
--------------------------------	--

Example: An acquisition system has a 512 x 512 element, 10 μ m pixel pitch area scan camera, a lens with an effective focal length of 45mm, and requires that 100 μ m in the object space correspond to each pixel in the image sensor. Using the preceding equation, the object distance must be 450mm (0.450m).

$\frac{10\mu m}{100\mu m} = \frac{45mm}{OD}$	$OD = 450mm$
--	--------------

Sensor Handling Instructions

This section reviews proper procedures for handling, cleaning, or storing the Genie Nano camera. Specifically the Genie Nano sensor needs to be kept clean and away from static discharge to maintain design performance.

Electrostatic Discharge and the Sensor

Cameras sensors containing integrated electronics are susceptible to damage from electrostatic discharge (ESD).

Electrostatic charge introduced to the sensor window surface can induce charge buildup on the underside of the window that cannot be readily dissipated by the dry nitrogen gas in the sensor package cavity. With charge buildup, problems such as higher image lag or a highly non-uniform response may occur. The charge normally dissipates within 24 hours and the sensor returns to normal operation.



Important: Charge buildup will affect the camera's flat-field correction calibration. To avoid an erroneous calibration, ensure that you perform flat-field correction only after a charge buildup has dissipated over 24 hours.

Protecting Against Dust, Oil and Scratches

The sensor window is part of the optical path and should be handled like other optical components, with extreme care.

Dust can obscure pixels, producing dark patches on the sensor response. Dust is most visible when the illumination is collimated. The dark patches shift position as the angle of illumination changes. Dust is normally not visible when the sensor is positioned at the exit port of an integrating sphere, where the illumination is diffuse.

Dust can normally be removed by blowing the window surface using a compressed air blower, unless the dust particles are being held by an electrostatic charge, in which case either an ionized air blower or wet cleaning is necessary.

Oil is usually introduced during handling. Touching the surface of the window barehanded will leave oily residues. Using rubber finger cots and rubber gloves can prevent oil contamination. However, the friction between the rubber and the window may produce electrostatic charge that may damage the sensor.

Scratches can be caused by improper handling, cleaning or storage of the camera. When handling or storing the Nano camera without a lens, always install the C-mount protective cap. Scratches diffract incident illumination. When exposed to uniform illumination, a sensor with a scratched window will normally have brighter pixels adjacent to darker pixels. The location of these pixels changes with the angle of illumination.

Cleaning the Sensor Window

Even with careful handling, the sensor window may need cleaning. The following steps describe various cleaning techniques to clean minor dust particles to accidental finger touches.

- Use compressed air to blow off loose particles. This step alone is usually sufficient to clean the sensor window. Avoid moving or shaking the compressed air container and use short bursts of air while moving the camera in the air stream. Agitating the container will cause condensation to form in the air stream. Long air bursts will chill the sensor window causing more condensation. Condensation, even when left to dry naturally, will deposit more particles on the sensor.
- When compressed air cannot clean the sensor, Teledyne DALSA recommends using lint-free ESD-safe cloth wipers that do not contain particles that can scratch the window. The Anticon Gold 9"x 9" wiper made by Milliken is both ESD safe and suitable for class 100 environments. Another ESD acceptable wiper is the TX4025 from Texwipe.
- An alternative to ESD-safe cloth wipers is Transplex swabs that have desirable ESD properties. There are several varieties available from Texwipe. Do not use regular cotton swabs, since these can introduce static charge to the window surface.
- Wipe the window carefully and slowly when using these products.

Ruggedized Cable Accessories

Teledyne DALSA provides optional I/O cable assemblies for Genie Nano. Users wishing to build their I/O cabling by starting from available cable packages should consider these popular assemblies described below. Contact Sales for pricing and delivery.

Users also may order cable assembly quantities directly from Alysium-Tech or Components Express. In such cases use the manufacturer's part number shown on the cable assembly engineering drawing.

Cable Manufactures Contact Information

For Information contact: <i>(see their web site for worldwide offices)</i>	Alysium-Tech 101 Montgomery Street, Suite 2050 San Francisco, CA 94104 Phone: 415 248 7807 Fax: 415 248 7800 https://www.alysium.com/
For Information contact: <i>(see their web site for worldwide offices)</i>	Components Express, Inc. (CEI) 10330 Argonne Woods Drive, Suite 100 Woodridge, IL 60517-4995 Phone: 630-257-0605 / 800.578.6695 (outside Illinois) Fax: 630-257-0603 http://www.componentsexpress.com/

Cable Assembly G3-AIOC-BLUNT1M



A65-3210
IO Industrial Assembly

DRAWING REF: A65-3210
DRAWING REF: IO Industrial Assembly

REVISION: 02 (WON 170802)
03 (WON 170825)
04 (WON 170830)
05 (WON 190509)
06 (WON 190510)

Change Polarization
Wiring Dia. Updates
Add Cable Info
Modify Connector
Add Sheet Details

Length (in meter), As per Customer Requirements

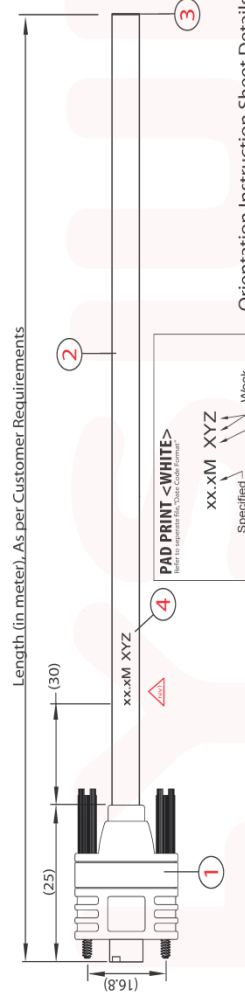

xx.xM XYZ

PAD PRINT <WHITE>
Specified Cable Length
Week
Year

#1 Mating Face View

Orientation Instruction Sheet Details:

Front



Back

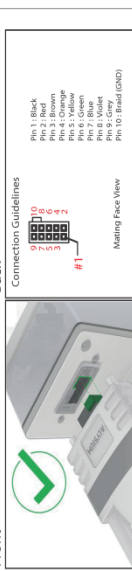

Connection Guidelines

Mating Face View

RoHS COMPLIANT

WIRING DIAGRAM

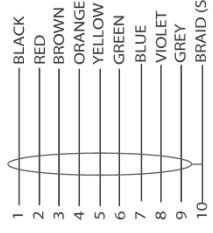

PACKAGING DETAIL

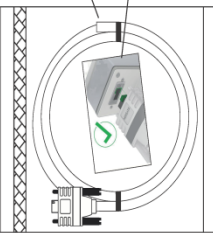

BILL OF MATERIALS

Item	Description
1	10P(1.27) DRsl (DCT)
2	A81-9756 (1.27mm Pitch Dual Row Board To Board 10P Dual Row)
3	A11-3069 [OD=4.5mm] <BLK> (UL20276 9C#30(7/0,10))
4	Processed End - Flat Cut Cable Label (White Pad Print)
5	Orientation Instruction Sheet
6	Heat Seal PE Bag

UNIT: mm
UNLESS OTHERWISE SPECIFIED

ASH LENGTH TOLERANCE

- < 150mm = ±0.25mm
- 150mm and < 250mm = ±0.5mm
- 250mm and < 500mm = ±1.0mm
- 500mm and < 1,000mm = ±3.0mm
- 1,000mm and < 3,000mm = ±5.0mm
- 3,000mm and above = ±10.0mm

This document is the property of Alysium-Tech. It must not be copied or otherwise disclosed without prior written consent.





Nano Generic Power Supply with no I/O

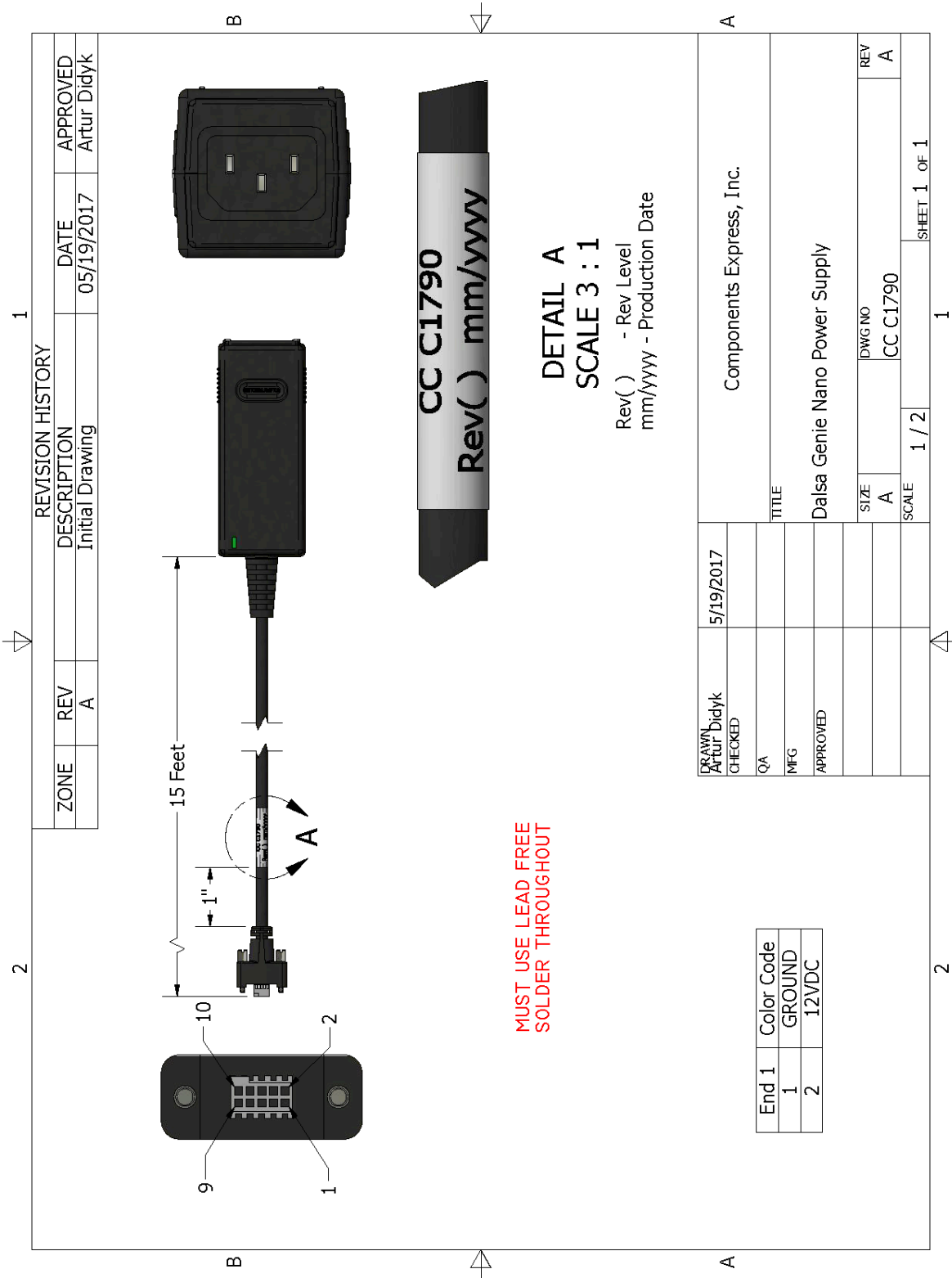

REVISION HISTORY				
ZONE	REV	DESCRIPTION	DATE	APPROVED
	A	Initial Drawing	05/19/2017	Artur Didyk

DRAWN Artur Didyk	5/19/2017	TITLE	
CHECKED		Components Express, Inc.	
QA		Dalsa Genie Nano Power Supply	
MFG		SIZE	DWG NO
APPROVED		A	CC C1790
		SCALE	1 / 2
		SHEET 1 OF 1	

End 1	Color Code
1	GROUND
2	12VDC

Components Express Right-Angle Cable Assemblies

These cable assemblies can be acquired directly from our partner [Components Express](#). In such cases use the manufacturer's part number shown on the cable assembly engineering drawing.

Cable Assembly: Right-Angle I/O Bunt End

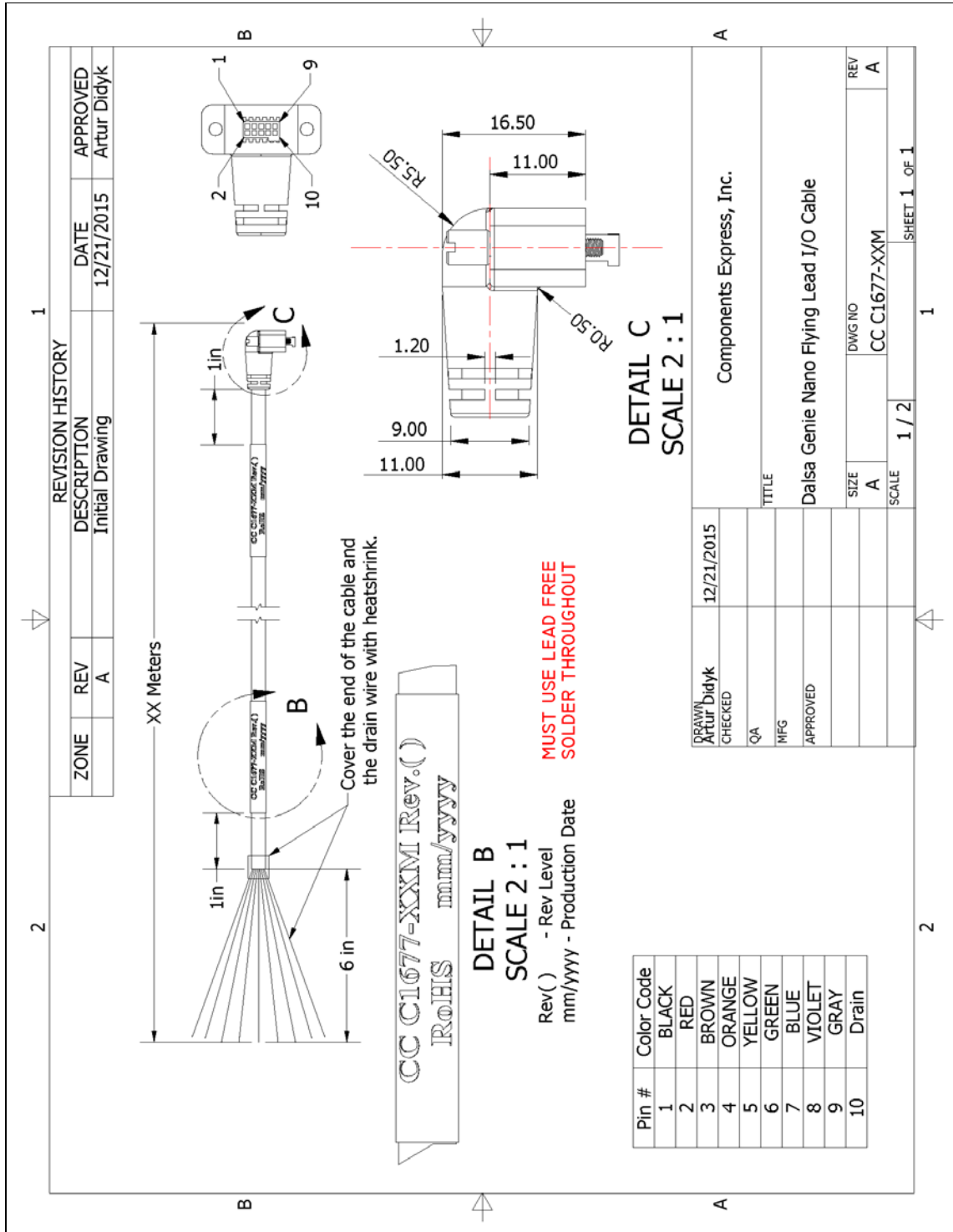

Cable Assembly: Right-Angle I/O to Euro Block

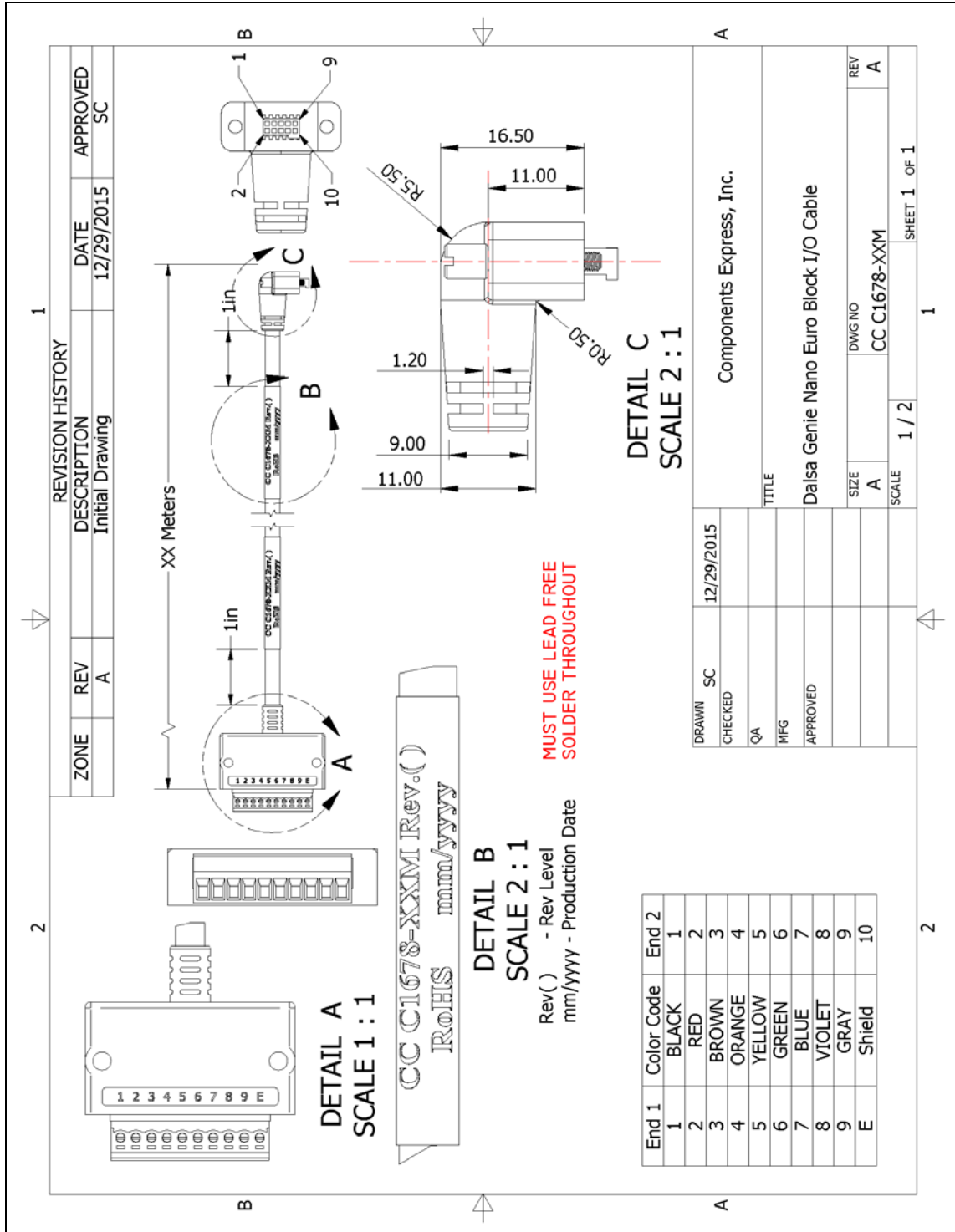

Troubleshooting

Overview

In rare cases an installation may fail or there are problems in controlling and using the Nano camera. This section highlights issues or conditions which may cause installation problems. Emphasis is on the user to perform diagnostics with the tools provided and methods are described to correct the problem.

Problem Type Summary

Nano problems are either installation issues due to cabling or power, or setup errors with the frame grabber configuration.

Before Contacting Technical Support

Carefully review the issues described in this Troubleshooting section. To aid Teledyne DALSA personnel when support is required, the following should be included with the request for support.

- From the Start menu, go to **Programs • Dalsa • Sopera LT • Tools** and run the **Log Viewer** program. From its File menu click on **Save Messages** to generate a log text file.
- Report the version of Genie Nano Firmware and Sopera version used.
- Report the frame grabber brand and model used. Provide specifications for any third part frame grabber used.

Device Available with Operational Issues

This section considers issues with frame grabbers, cabling, multiple cameras and camera exposure.

Firmware Updates

As a general rule any Nano installation must include the firmware update procedure to ensure having the latest build (see File Access Control Category).

Note:

- A Nano-CL that had a fault with a firmware update will automatically recover by booting with the previous firmware version.



Important: New Nano-CL cameras installed in previously deployed systems are fully backward compatible with the older vision application.

Power Failure during a Firmware Update—Now What?

Don't panic! There is far greater chance that the host computer OS is damaged during a power failure than any permanent problems with the Nano. When electrical power returns and the host computer system has restarted follow this procedure.

- Connect power to the Nano-CL. The Nano processor knows that the firmware update failed.
- The Nano-CL will boot with the previous version of firmware and will operate normally.
- The [Nano Self Status](#) (deviceBISTStatus) will return that the last firmware update failed.
- Perform the firmware update procedure (see File Access Control Category) again.

Cabling and Communication Issues

With only camera link cables and possibly an external power supply connected to Nano-CL, possible cabling issues are limited.

Power supply problems:

- If the Nano status LED is off, the DC supply power is not connected or faulty. Verify the power supply voltage.
- If using PoCL power, use both camera link cables connected to the frame grabber and verify that the frame grabber used has activated its PoCL source.

Communication Problems:

- Use shielded cables where the connector shell electrically connects the Nano chassis to the power supply earth ground. This can eliminate trigger issues in a high EMI environment. Purchase camera link cables from quality certified sources.
- Use the Log Viewer tool (see point below) for error conditions.
- Run the Sapera Log Viewer: **Start • Programs • Teledyne DALSA • Sapera LT • Tools • Log Viewer**. Start the Nano-CL acquisition program, such as CamExpert. Review the log output for error messages.

Recommended Hardware

The Nano-CL has a Camera Link Pixel Clock of 85MHz. Teledyne DALSA Xtium series frame grabbers are recommended for error free acquisitions (contact sales for additional information).

Cable Length Considerations

- The camera outputs data at 85MHz on the Camera Link cable.
- The high data rate on the Camera Link cable can cause compatibility issues based on cable quality, cable length and Frame Grabber used.
- Teledyne DALSA has qualified the Xtium frame grabber with 10 meter cables at 85MHz (10-tap configuration). Camera Link cables (end to end standard solutions of various lengths) are recommended from Components Express and Alysium, who also offer I/O signal solutions as described in this manual. See [Cable Manufactures Contact Information](#) for contact information.
- The Teledyne DALSA Xcelera frame grabber (10-tap configuration) has been qualified using up to 4 meter cables with the Nano-CL.
- Use of third party frame grabbers and other cables requires thorough testing by the user.

Nano-CL — Minimum horizontal Sync

- The camera requires a frame grabber that supports a LVAL signal of 4 clock cycles when operating in Fast Readout mode (applicable to OnSemi sensor cameras).
- Older generation frame grabbers (such as the Teledyne DALSA Xcelera PX8) can show compatibility issues resulting in corrupted images. To be compatible with older frame grabbers, the camera should be operated in Normal Readout mode. See feature *fastReadoutMode* in the [Sensor Control Feature Descriptions](#).

Camera is functional, frame rate is as expected, but image is black

- If using an external trigger exposure (via the frame grabber), verify the trigger source rate and pulse width coming from the grabber parameters.
- Verify that the lens iris is open.
- Aim the Nano-CL at a bright light source.
- Check that the programmed exposure duration is not too short or set it to maximum. See Sensor Control Category.
- Using CamExpert set the Nano-CL to output its Internal Pattern Generator. This step is typically done for any camera installation to quickly verify the Nano and its software package. See Internal Test Pattern Generator for information on using CamExpert to select internal patterns from Nano.

Other Problems or Issues

This section describes problems that do not fit any of the categories above. Typically these are issues found in the field under specific or unusual conditions.

Revision History

Revision	Date	Major Change Description
R:0001	May 28, 2018	Initial release
R:0002	March 7, 2019	Various manual improvements and technical corrections
R:0003	October 15, 2019	Various manual improvements and technical corrections. Addition of models 4160 using Teledyne E2V Emerald EV2S16M sensors.

Contact Information

Sales Information

Visit our web site:

www.teledynedalsa.com/mv

Email:

<mailto:info@teledynedalsa.com>

Canadian Sales

Teledyne DALSA — Head office
605 McMurray Road
Waterloo, Ontario, Canada, N2V 2E9
Tel: 519 886 6000
Fax: 519 886 8023

Teledyne DALSA — Montreal office
880 Rue McCaffrey
Saint-Laurent, Quebec, Canada, H4T 2C7
Tel: (514) 333-1301
Fax: (514) 333-1388

USA Sales

Teledyne DALSA — Billerica office
700 Technology Park Drive
Billerica, Ma. 01821
Tel: (978) 670-2000
Fax: (978) 670-2010

European Sales

Teledyne DALSA GMBH
Lise-Meitner-Str. 7
82152 Krailling (Munich), Germany
Tel: +49 – 89 89545730
Fax: +49 – 89 895457346
sales.europe@teledynedalsa.com

Asian Sales

Teledyne DALSA Asia Pacific
Ikebukuro East 13F
3-4-3 Higashi Ikebukuro,
Toshima-ku, Tokyo, Japan
Tel: +81 3 5960 6353
Fax: +81 3 5960 6354

Shanghai Industrial Investment Building
Room G, 20F, 18 North Cao Xi Road,
Shanghai, China 200030
Tel: +86-21-64279081
Fax: +86-21-64699430

Technical Support

Submit any support question or request via our web site:

Technical support form via our web page:
Support requests for imaging product installations,
Support requests for imaging applications

Camera support information

Product literature and driver updates

<http://www.teledynedalsa.com/mv/support>

