

THE POWER AND SPEED OF VISION



USER MANUAL

ELIIXA+ NBase-T COLOR



Table of Contents

1 Camera Overview	5
1.1 Features	5
1.2 Key Specifications	5
1.3 Description.....	6
1.4 Applications	6
1.5 Models	6
2 Camera Performances	7
2.1 Camera Characterization	7
2.2 Image Sensor and colour modes	7
2.2.1 True Colour mode in 2k 10µm	8
2.2.2 Full Definition Modes in 4k 5µm	10
2.3 Response & QE curves.....	11
2.3.1 Quantum Efficiency	11
2.3.2 Spectral Response	12
3 Camera Hardware Interface.....	13
3.1 Input/output Connectors and LED.....	14
3.2 Power Connector	14
3.2.1 Status LED Behaviour.....	15
3.3 GPIO Connector	15
4 STANDARD CONFORMITY	17
4.1 CE Conformity.....	17
4.2 FCC Conformity.....	17
4.3 RoHS Conformity.....	17
5 Camera Interface : NBASE-T™	18
5.1 What is the NBASE-T™ Technology ?	18
6 Camera Interface Overview	19
6.1 Inputs, Outputs and Enhanced Features	19
7 Camera Commands	21
7.1 Device Control	21
7.2 Image Format Control	22
7.2.1 Image Format	22
7.2.2 Meta Data	22
7.2.3 Regions of Interest.....	23

7.3 Transport Layer Control.....	25
7.4 Acquisition Control	28
7.4.1 GenICam Triggers	28
7.4.2 Cycling Preset modes and configuration	32
7.4.3 Full Exposure Control Mode (4k Full Definition Enhanced only).....	34
7.5 Digital I/O Control.....	36
7.6 Enhanced Features Control	41
7.6.1 Rotary Encoder, Rescaler and Frame Delay.....	41
7.6.2 Counters & Timers	42
7.7 Gain Control.....	49
7.8 Flat Field Correction Control	51
7.8.1 FFC Calibration and Bank/Preset Saving.....	51
7.8.2 PRNU Low Frequency Filter for FFC.....	53
7.9 Color Management Control.....	55
7.9.1 White Balance.....	55
7.9.2 RGB Color Matrix	55
7.10 Device Access Control.....	60
7.11 Save and Restore	60
APPENDIX	62
Appendix A. Pattern Tests	63
Appendix B. Timing Diagrams	64
B.1 Synchronization modes with variable Exposure Time	64
B.2 Synchronization modes with Fixed Exposure Time	65
B.3 Timing Values	65
Appendix C. Accessories	66
C.1 F-Mount.....	66
C.2 C-Mount.....	67
C.3 Set of Heatsinks	68
Appendix D. Network Connection.....	69
D.1 Single Network Board + Cables (GPIO + Power) Kit	69
D.2 Dual Network Board + Cables (GPIO + Power) Kit	69
D.3 Ethernet Cable.....	69
D.4 PureGev Application and eBus Package.....	70
D.5 Driver Configuration and Inter-Operability.....	70
Appendix E. Revision History	71

1 Camera Overview

1.1 Features

- Cmos Colour Sensor :
 - 4096 RGB Pixels 5x5µm (Full Definition)
 - 2048 RGB Pixels 10x10µm (True Colour)
- Interface : NBASE-T™ (up to 5Gb/s)
- Line Rate :
 - 50 000 l/s In 4k Full Definition Mode
 - 100 000 l/s in 2k True Colour Mode
- Bit Depth : 24bits (RGB 8bits)
- Scan Direction
- Flat Field Correction
- Cycling Preset Modes and Memories
- Multi ROI
- Metadata
- Rotary Encoder

1.2 Key Specifications

Characteristics	Typical Value		Unit
Sensor Characteristics at Maximum Pixel Rate			
Resolution	4096	2048	RGB Pixels
pixel size (square)	5	10	µm
Max Line Rate	50	100	kHz
Radiometric Performance at Maximum Pixel Rate and minimum camera gain			
Bit depth	3 x 8		Bits
Response non linearity	< 1		%
PRNU HF Max	3		%
Dynamic range	65		dB
Peak Response (All Modes)			
Red	11.8		LSB 8bits/(nJ/cm ²)
Green	11.2		LSB 8bits/(nJ/cm ²)
Blue	7.8		LSB 8bits/(nJ/cm ²)

Test conditions :

- All values are given at Nominal Gain (0dB) : Preamp Gain x1, Amp Gain 0dB
- Figures in LSB are for a 8bits format
- Measured at exposure time = 400µs and line period = 400µs in Ext Trig Mode (Max Exposure Time)
- Maximum data rate

Functionality (Programmable via GenICam Control Interface)		
Analog Gain	Up to 12 (x4)	dB
Trigger Mode	Timed (Free run) and triggered (Ext Trig, Ext ITC) modes	
Sensor Modes	<ul style="list-style-type: none"> • True Colour Enhanced : 2048 RGB Pixels of 10x10µm • True Colour Single : 2048 RGB Pixels of 10x10µm • Full Definition Enhanced : 4096 RGB Pixels 5x5µm • Full Definition Single : 4096 RGB Pixels 5x5µm 	
Mechanical and Electrical Interface		
Size (w x h x l)	60 x 60 x 55	mm
Weight	247/335 without/with Heat Sinks	g
Lens Mounts	C, F, T2, M42 (embedded in the Front Face)	-
Sensor alignment	±100	µm
Sensor flatness	±50	µm
Power supply	12 - 24	V
Power dissipation	< 11	W
General Features		
Operating temperature	0 to 60 (front face) or 85 (Internal)	°C
Storage temperature	-40 to 70	°C
Regulatory	CE, FCC and RoHS compliant	

1.3 Description

To maintain their competitive advantage, industrial leaders in the machine vision market have a continuous requirement to improve defect detection accuracy and reduce the cost of imaging. The availability of the ELiXA+ cameras with an NBASE-T™ connection offers a straightforward solution, providing:

- High throughput - enabling high resolution and colour imaging without a frame grabber at speeds of up to 5 Gigabits per second (Gbps) over Category 5e standard Ethernet cable.
- Easy integration – compatible with GigE Vision protocol.
- Long-length (100 meters+), field terminable, inexpensive cabling - reduces costs and enables easier integration in imaging systems compared with optic fibre cabling

1.4 Applications

- Raw material surface inspection
- Parcel and postal sorting
- High resolution document scanning
- Printing inspection
- Industrial Inspection

1.5 Models

Part Number	Definition	Max Speed	Details
EV71YC4CNT4005-BA0	4k x 5µm	50kHz	Delivered with a pair of Heat Sinks
EV71YC4CNT2010-BA0	2k x 10µm	100kHz	

2 Camera Performances

2.1 Camera Characterization

	Unit	Single Modes		Enhanced Modes	
		Typ.	Max	Typ.	Max
Dark Noise RMS	LSB	0.45	0.8	0.45	0.8
Dynamic Range	db	53	-	53	-
RMS Noise (3/4 Sat)	LSB	2.15	4	2.2	4
Full Well Capacity	e ⁻ (per color)	22000	-	22000	-
SNR (3/4 Sat)	dB	42	-	42	-
Peak Response (460/530/660nm)	LSB 8bits/ (nJ/cm ²)	4/5/6	-	8/10/12	-
Non Linearity	%	0,3	-	0,3	-
Without Flat Field Correction :					
FPN rms	LSB	0.15	0.5	0.15	0.5
FPN pk-pk	LSB	0.85	2	0.85	2
PRNU hf (3/4 Sat)	%	0.24	0,5	0.24	0,5
PRNU pk-pk (3/4 Sat)	%	1.7	3	1.25	3

- All LSB Values are in 8bits (RGB : 3x8bits) at nominal Gain

2.2 Image Sensor and colour modes

The ELiIXA+ Colour 4k/2k sensor is composed of two pairs of sensitive lines. The Colour version has been completed with RGB colour Filter and disposed as detailed beside.

Each pair of lines uses the same Analog to Digital Column converter (ADC Column). An appropriate (embedded) Time delay in the exposure between each line this allows to combine two successive exposures in order to double the sensitivity of a single line.

This Time Delay Exposure is used only in the Full Definition Enhanced mode (See Below).

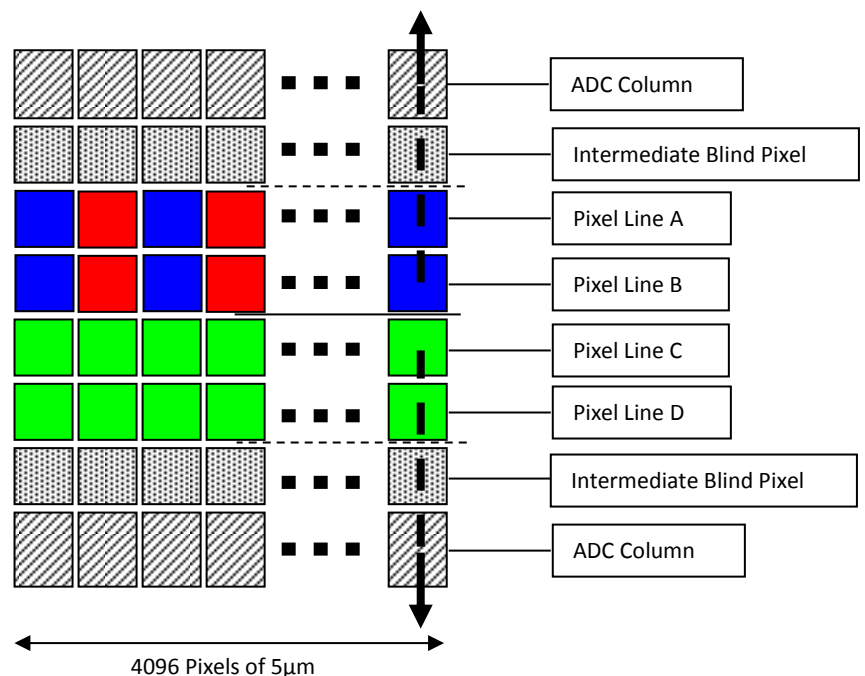

2.2.1 True Colour mode in 2k 10µm

True Colour Enhanced Mode (TCE)

10µm Pixels (R,G,B)

Twice less pixels than B/W

Requires x3/2 the data flow of B&W

- High Sensitivity True Colour mode: Equivalent to 6 x Pixels of 5µm (with their respective colour filters).
- “Full Exposure control” not needed in TC as the TDI is not active (only binning). The Exposure time can be control as for a single line mode.

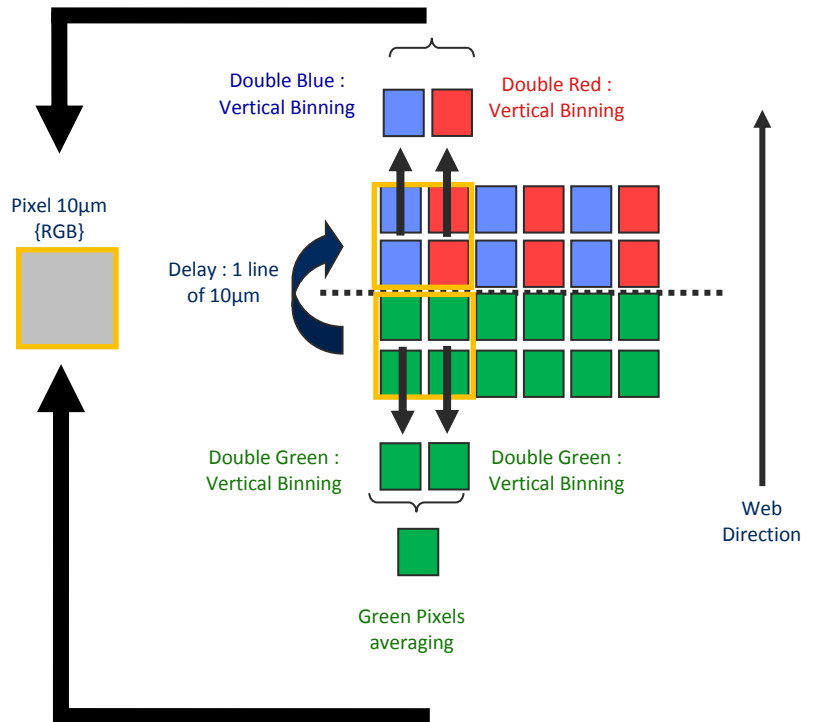

True Colour Single Mode (TCS)

10µm Pixels (R,G,B)

Twice less pixels than B/W

Requires x3/2 the data flow of B&W

- Sensitivity Half of the TCE mode: Equivalent to 3 x Pixels of 5µm (with their respective colour filters).
- “Full Exposure control” not needed in TC as the TDI is not active (only binning). The Exposure time can be control as for a single line mode.
- Not sensitive to the Scanning direction and the variation of the aspect ratio of the image.

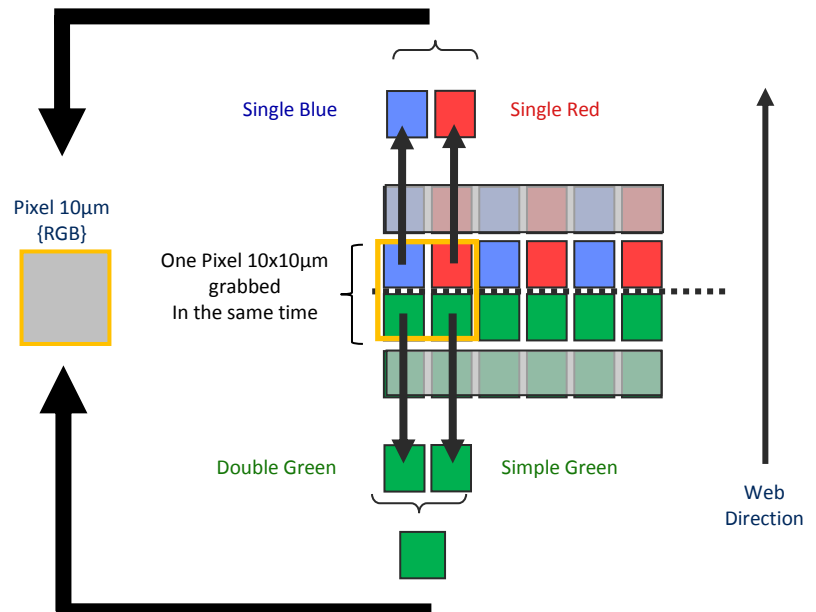

Column Interpolation Correction

This interpolation is used to compensate the colour error in the Red or the Blue in case of a vertical transition on the web : The Red or the blue value of each coloured pixel is corrected if the variation between two neighbour green pixels is significant.

$B_1' = \alpha_B \times B_1$ and α_B is the blue correction, calculated with the variation $(G_1 - G_2)$

$R_2' = \alpha_R \times R_2$ and α_R is the red correction, calculated with the variation $(G_1 - G_2)$

- This interpolation is available only for pixel size 10x10µm (True Colour only)
- It can be disabled by the customer. By default, it is enabled.

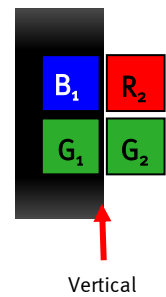

Line Interpolation Correction

This interpolation is used to compensate the colour error in the Red or the Blue in case of a horizontal transition on the web in the same "True Colour" pixel : A line is memorized and the Red or the blue value of each coloured pixel is corrected if the variation between two consecutive green values (previous to next line) is significant :

$B_1' = \alpha_B \times B_1$ and α_B is the blue correction, calculated with the variation $(G_1 - G'_1)$

$R_2' = \alpha_R \times R_2$ and α_R is the red correction, calculated with the variation $(G_2 - G'_2)$

- This interpolation is available only for pixel size 10x10µm (True Colour Single only)
- It can be enabled by the customer. By default, it is disabled
- This interpolation requires the Forward/Reverse indication sent to the camera for the memorized line.

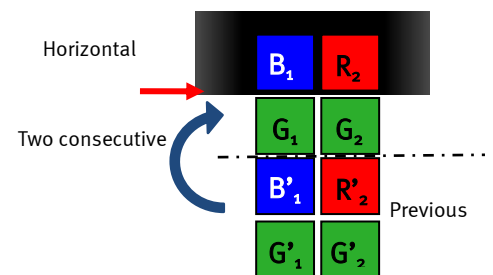

The Line Interpolation **has to be disabled** if the light is changing for each Line (typically for pulsed Light source with different spectrum) or for any reason the Green component of the light source changes significantly from one line to the next one.

Effects of the interpolation corrections

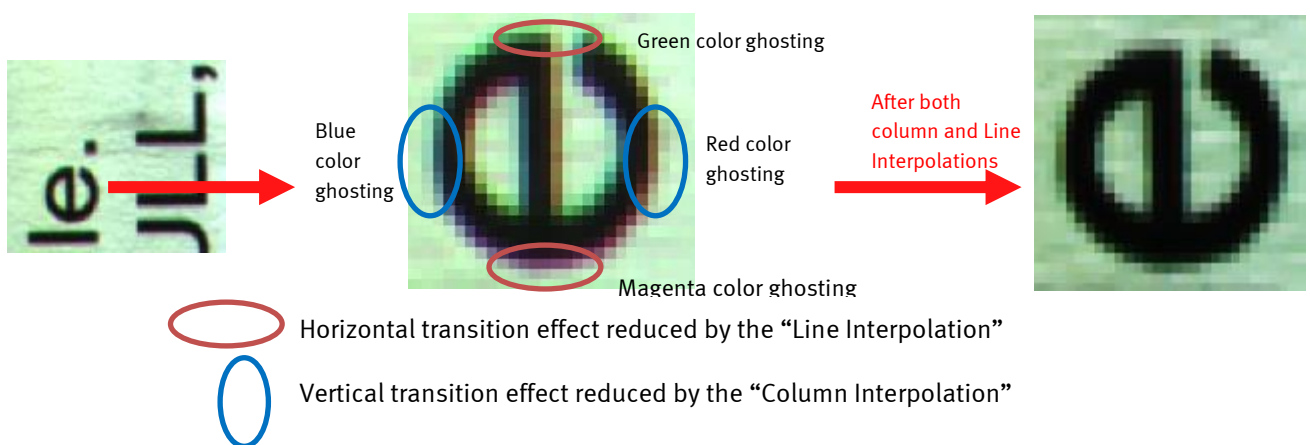

2.2.2 Full Definition Modes in 4k 5µm

Full Definition Single Mode (FDS)

5µm Pixels (R,G,B)

Same definition than B&W

Requires x3 the data flow of the B&W

- Sensitivity is half of the TC mode available : Equivalent to 3 x Pixels of 5µm (with their respective colour filters).
- “Full Exposure control” not needed in this mode as the Time Delay Exposure is not active. The Exposure time can be control as for a single line mode.

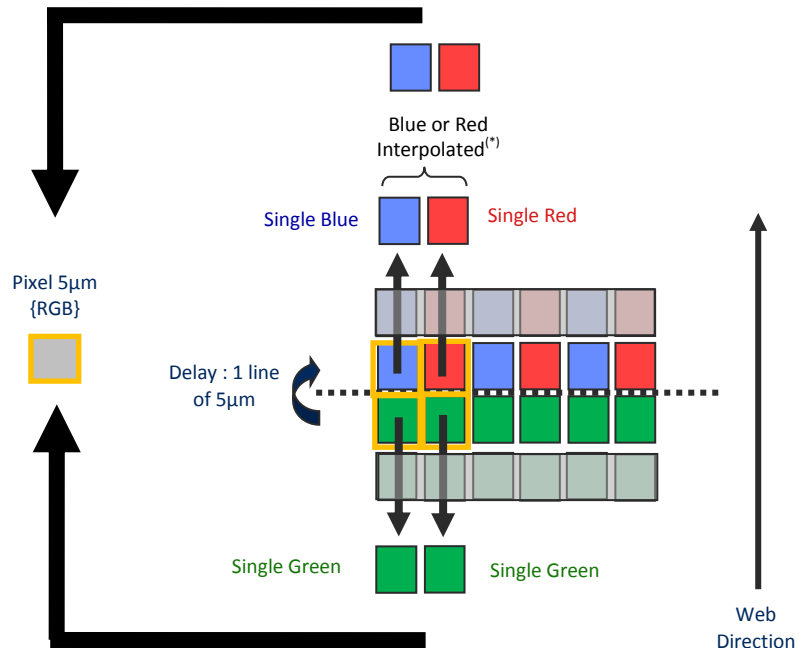

Full Definition Enhanced Mode (FDE)

5µm Pixels (R,G,B)

Same definition than B&W

Requires x3 the data flow of the B&W

- Sensitivity is the same as the TC mode available : Equivalent to 6 x Pixels of 5µm (with their respective colour filters).
- “Full Exposure control” is activated in this mode as the Time Delay Exposure is active.

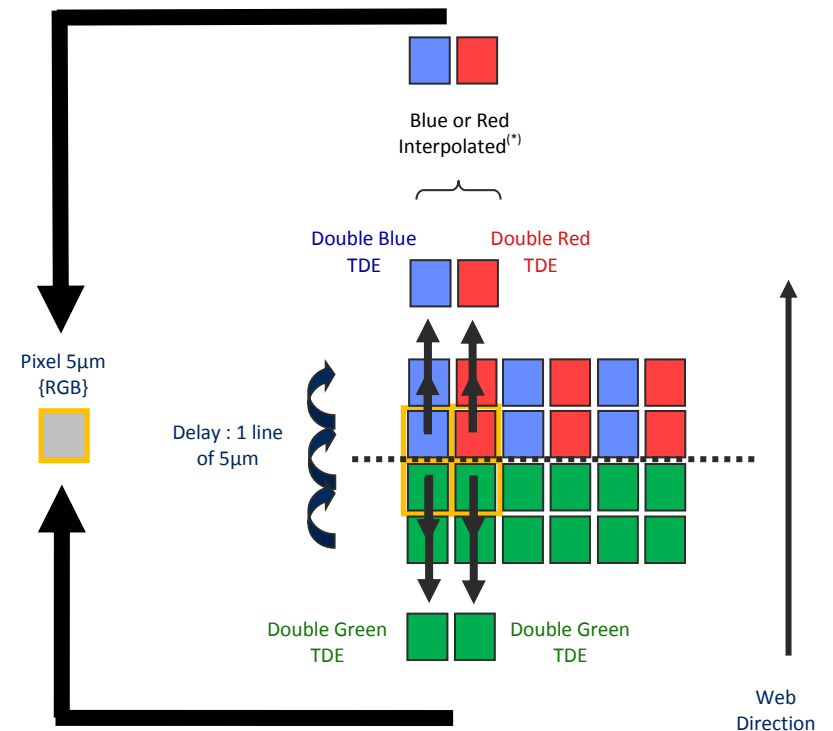

Color Interpolation in Full Definition modes.

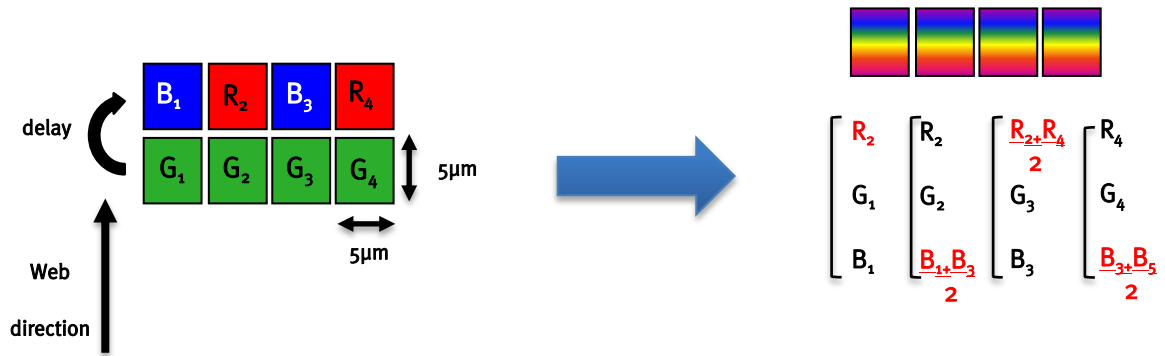

This colour mode (5µm) requires the indication of “Forward/Reverse” to the camera in order to manage the delay between the two coloured lines.

2.3 Response & QE curves

2.3.1 Quantum Efficiency

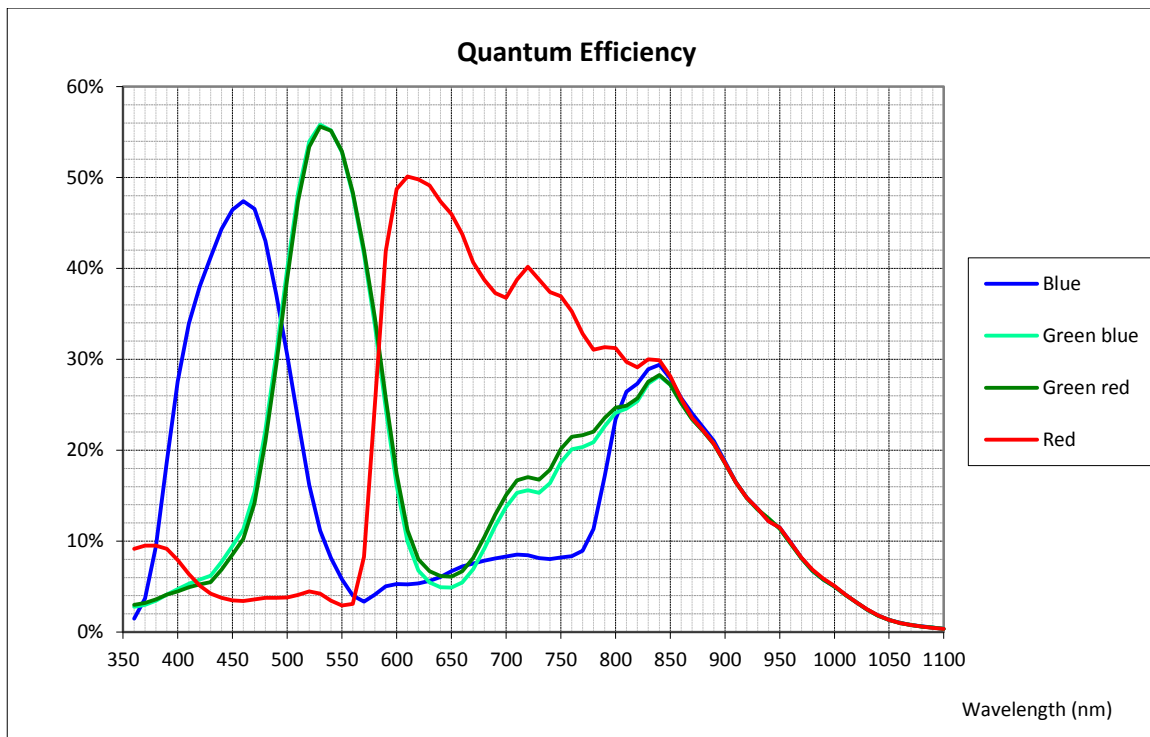

2.3.2 Spectral Response

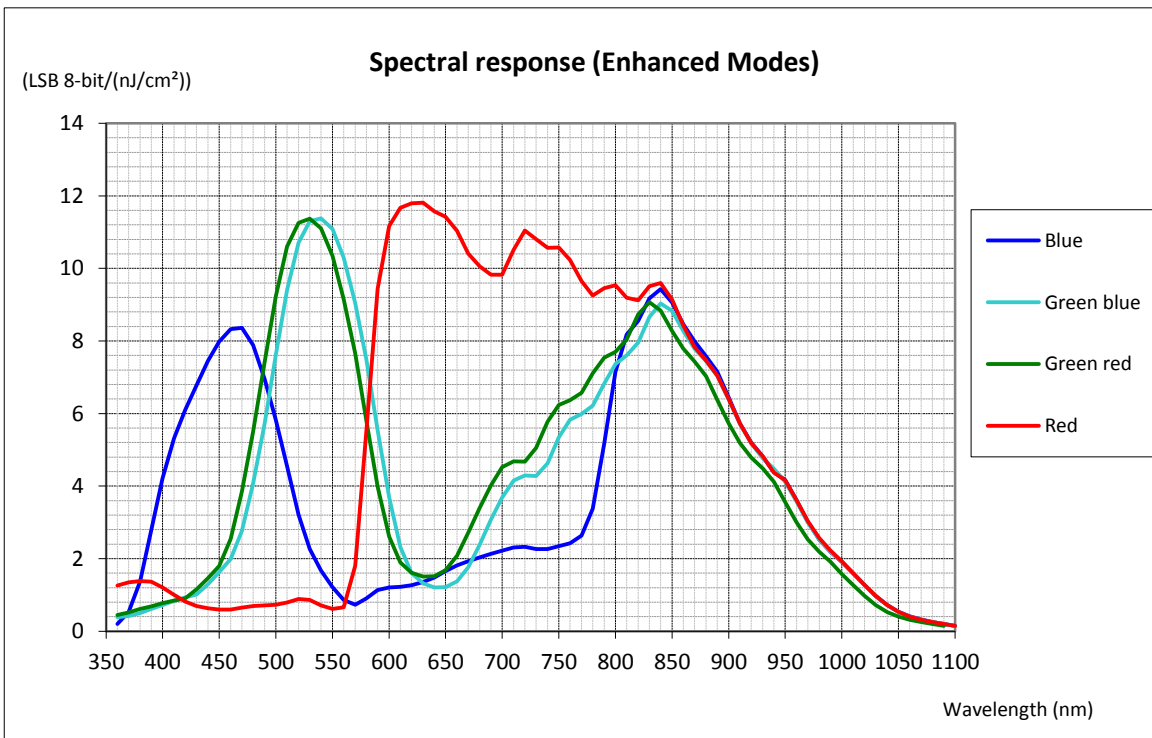
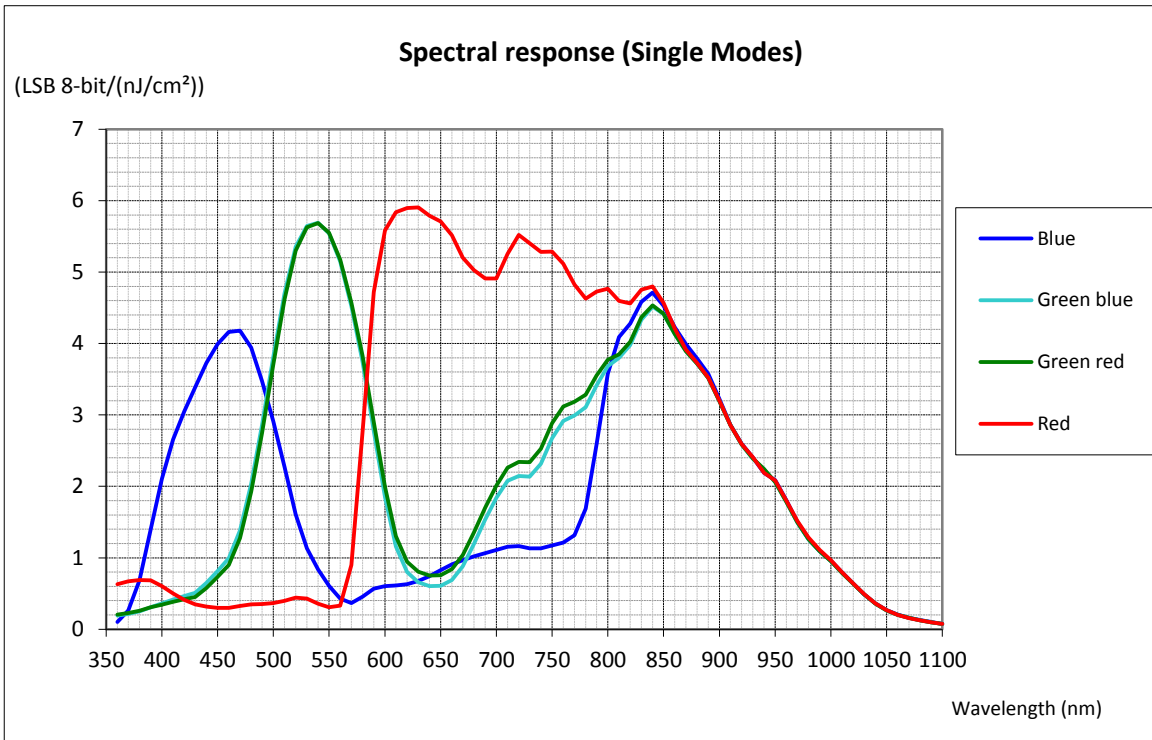

3 Camera Hardware Interface

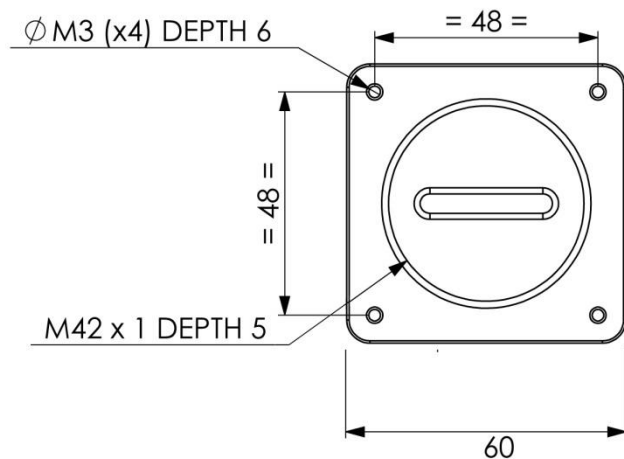
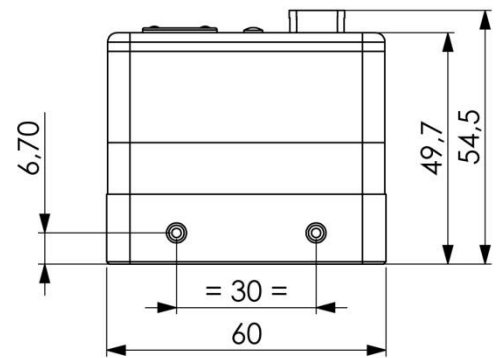
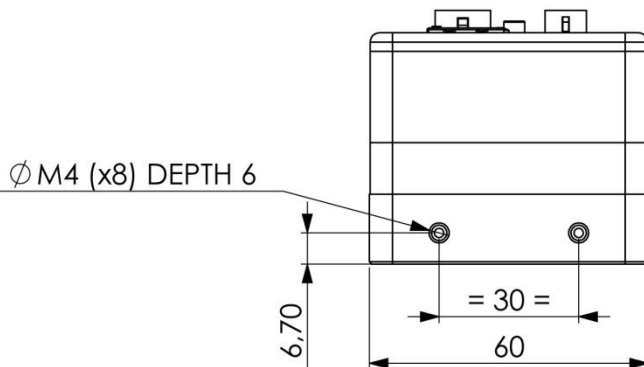
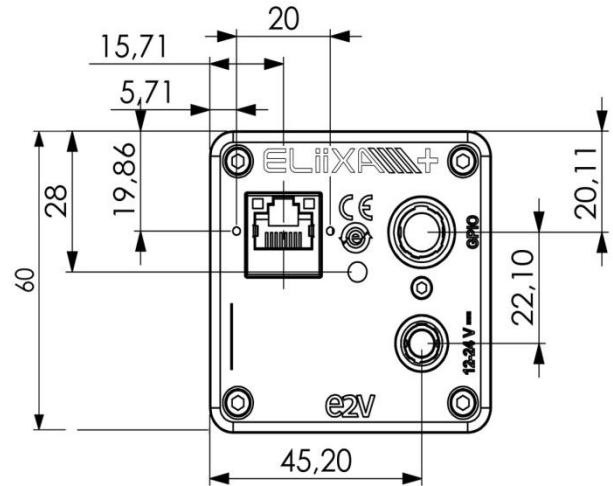
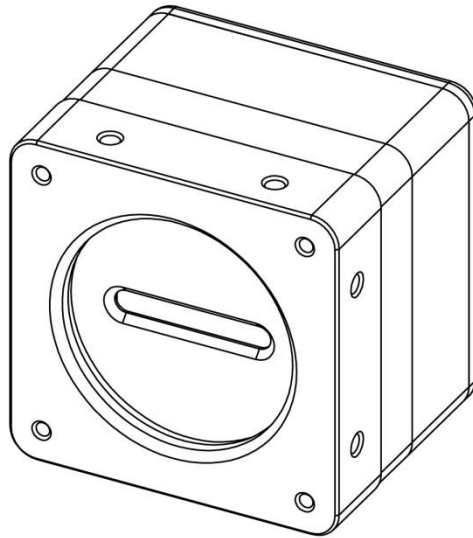

Sensor alignment	
Z = -10.3 mm	±100µm
X = 19.76 mm (4k 5µm)	±100 µm
X = 19.76 mm (2k 10µm)	
Y = 30 mm	±100 µm
Die flatness	50 µm
Rotation (X,Y plan)	±0.3°
Parallelism	50µm

3.1 Input/output Connectors and LED



3.2 Power Connector

Camera connector type: Hirose HR10A-7R-6PB (male)

Cable connector type: Hirose HR10A-7P-6S (female)

Signal	Pin	Signal	Pin
PWR	1	GND	4
PWR	2	GND	5
PWR	3	GND	6

Power supply from 12 to 24V
Power 11W max with an almost no inrush current peak

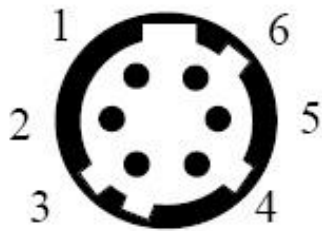

Camera side description

First 90ms after Power Up : The maximum p

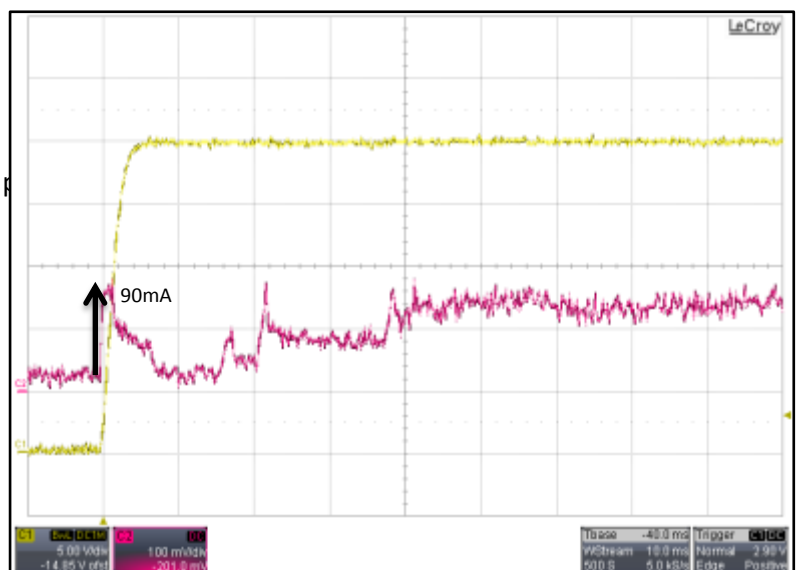

The complete Boot sequence :

- No real peak of Inrush current
- Several steps up to the nominal current (about 430mA under 24V)

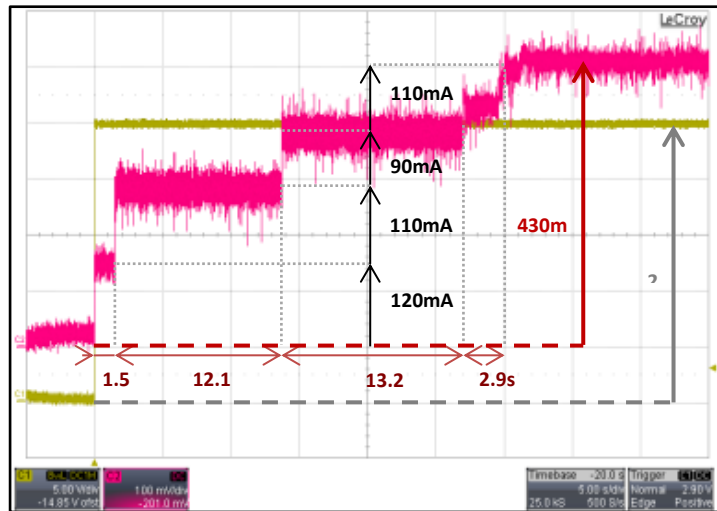

If the NIC Board (on PC Side) is not forced at 5Gb/s (no Auto-Negotiation or 10Gb/s) then a peak of 1,5A can be observed at the boot on the camera power Supply. The 10Gb/s connection is required only if you want achieve the real 5Gb/s (50kHz in 4k) otherwise you can force the connection at 5Gb/s : This could prevent the camera to complete a safe boot (depending on the Power provided)

3.2.1 Status LED Behaviour

After less than 2 seconds of power establishment, the LED first lights up in WHITE. Then after a Maximum of 40 seconds, the LED must turn in a following colour :

Colour and state	Meaning
Green and continuous	OK
Green and blinking slowly	Waiting for Ext Trig (Trig1 and/or Trig2)
Red and continuous	Camera out of order : Internal firmware error
Blue and continuous	Recovery (Upgrade mode) or Start boot sequence

3.3 GPIO Connector

Camera Connector type: Hirose HR10A-10R-12SB

Cable Connector type: Hirose HR10A-10R-12P

Cable type: cable immune from interference and with twisted pairs

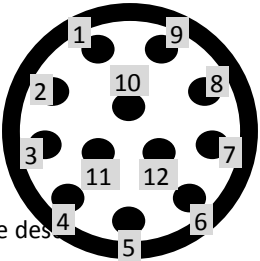
Camera side des	Signal		Pin	
	Signal	Pin	Signal	Pin
	Line 0+	1	Line 3+	7
	Line 0-	2	Line 4+	8
	Line 1+	3	Line 5+	9
	Line 1-	4	Line 6+	10
	Line 2+	5	GND	11
	Line 2-	6	GND	12

Lines 0, 1 and 2

The GPIO Connector allows the following connections :

- **Line 0, 1 or 2** : Dedicated inputs for Line Triggers and Frame Trigger. Differential (RS422 with or without termination) or TTL (Single End) in 3.3V, 5V, 12V or 24V.

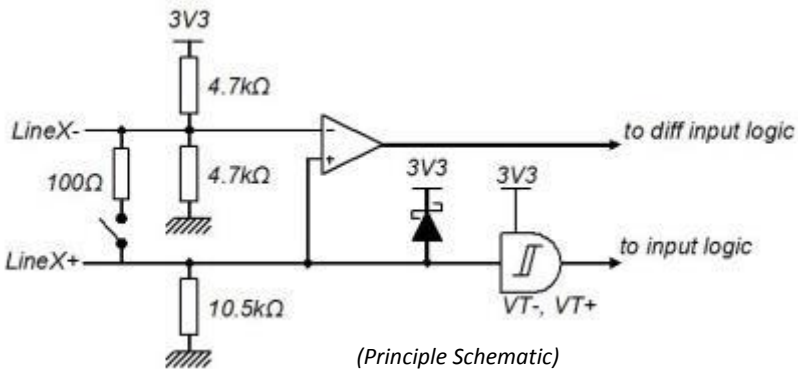

Input Thresholds	VT- Min	VT+ Max	Unit
24V	5.5	10.7	V
12V	2.1	5.5	V
3.3 / 5V	0.5	2	V

Lines 3, 4, 5 and 6

- **Line 3, 4, 5 and 6** : Configurable Inputs or Outputs in TTL only :
 - Input Configuration : Single End in 3.3V, 5V, 12V or 24V
 - Output configuration : Single End or Open Collector in 3.3V, 5V, or Camera power Supply

INPUT Configuration

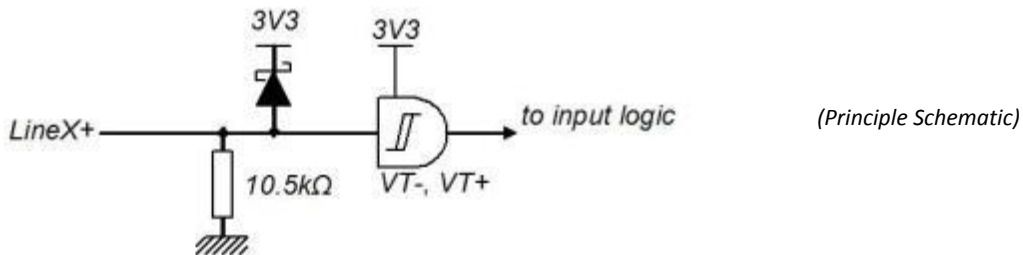

OUTPUT Configuration

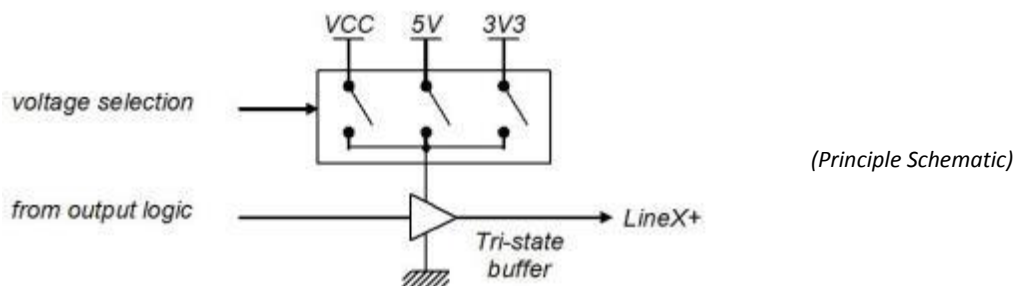

Output Lines have a limited current of 100mA : You have to make sure that each output is connected on sufficient resistance (depending on the output voltage) to avoid an over current which could damage the output circuit.

4 STANDARD CONFORMITY

The ELIIXA+ cameras have been tested using the following equipment:

- A shielded power supply cable
- A GigE cat 5E data transfer cable ref.

e2v recommends using the same configuration to ensure the compliance with the following standards.

4.1 CE Conformity

The ELIIXA+ cameras comply with the requirements of the EMC (European) directive 2004/108/EC (EN50081-2, EN 61000-6-2).

4.2 FCC Conformity

The ELIIXA+ cameras further comply with Part 15 of the FCC rules, which states that: Operation is subject to the following two conditions:

- This device may not cause harmful interference (EN55032), and
- This device must accept any interference received, including interference that may cause undesired operation (EN55024)

This equipment has been tested and found to comply with the limits for Class A digital device, pursuant to part 15 of the FCC rules. These limits are designed to provide reasonable protection against harmful interference when the equipment is operated in a commercial environment. This equipment generates, uses and can radiate radio frequency energy and, if not installed and used in accordance with the instruction manual, may cause harmful interference to radio communications. Operation of this equipment in a residential area is likely to cause harmful interference in which case the user will be required to correct the interference at his own expense.

Warning: Changes or modifications to this unit not expressly approved by the party responsible for compliance could void the user's authority to operate this equipment.

4.3 RoHS Conformity

ELIIXA+ cameras comply with the requirements of the RoHS directive 2011/65/EU.

5 Camera Interface : NBASE-T™

5.1 What is the NBASE-T™ Technology ?

NBASE-T™ technology defines a new type of Ethernet signaling that boosts the speed of installed based twisted-pair cabling well beyond the cable's designed limit of 1 Gigabit per second (Gbps) for distances up to 100 meters.

Capable of reaching 2.5 and 5 Gbps using the large installed base of Cat5e and Cat6 cabling, NBASE-T™ solutions enable users to accelerate their networks in the most cost-effective, least disruptive manner.

Flexible silicon solutions can auto-negotiate the optimal network speed, be it the new NBASE-T™ rates, slower 2.5 Gbps and 5 Gbps rates and even 10Gbps for very high speed networks.

To introduce these new cameras, e2v has partnered with PLEORA Technologies, the world's leading supplier of high-performance video interfaces, the first company from the machine vision industry to join the NBASE-T™ Alliance, a consortium collaborating on new technologies that extend the bandwidth capabilities of twisted-pair copper cabling using standard Ethernet technology.



Then all NBASE-T™ ELiXA+ are licensed for Pleora eBus SDK and PureGeV Software that you can download on Pleora website (<http://www.pleora.com/our-products/ebus-sdk>)



The ELiXA+ NBASE-T™ Camera is not compliant with a standard 1 Gbps NIC Board : You need a 5/10Gbps Board (as the N-420 PCIe that can be delivered in option).



The following recommendations have to be taken in account for the configuration of the Board in order to achieve optimal performances :

- If you don't need to reach the Highest speed (5Gbps), you can fix the Board speed connection to 5Gbps (instead of Auto-Negotiation) : This will avoid a significant peak of current of 1.5A at the Power Up.
- To reach the maximum throughput (5 Gbps which is equivalent to 50kHz in 4k pixels):
 - Update NIC driver (at least 4.4.405.152)
 - NIC board configuration:
 - > 10Gb/s connection
 - > Packet Size at 8192
 - > Enable Jumbo packet
 - > Number of RX Descriptors : 1000 (maximum)
 - > Number of TX Descriptor : 1000 (maximum)

6 Camera Interface Overview

6.1 Inputs, Outputs and Enhanced Features

- The Digital I/O Module allows the connection of 7 external Lines :
 - 3 dedicated inputs (Line 0, 1 and 2) that can generate 2 Line Triggers (LT1 and LT2) and one Frame Trigger (FT) that will be used as inputs in the Enhanced features Block.
 - 4 convertible generic Inputs / Outputs (Line 3, 4, 5 and 6) that can generate up to 4 additional Input Lines (L3, 4, 5 and 6) that will be used also in the Enhanced features Block or Used as Outputs.
 - A flexible in/Out block in RS422 or TTL with different detection levels (3.3v, 5v, 12v, 24v)
 - A Debounce and Inverter block that can filter and invert the internal Signals Inputs once affected to LT1, LT2, FT, L3, L4, L5 or L6.

- The Enhanced Feature block completes the treatment on internal signals to generate Triggers :
 - A delay dedicated to the Frame Trigger only (FT)
 - A Full Rotary Encoder management (Quadratic with or without reverse miscount) that use by default LT1 and LT2 as A/B Inputs. It can be bypassed to output by default LT1 as single Line Trigger input.
 - A Rescaler following the Rotary Encoder module (available also if Rotary Encoder is bypassed)
 - 2x Counters and 2x Timers

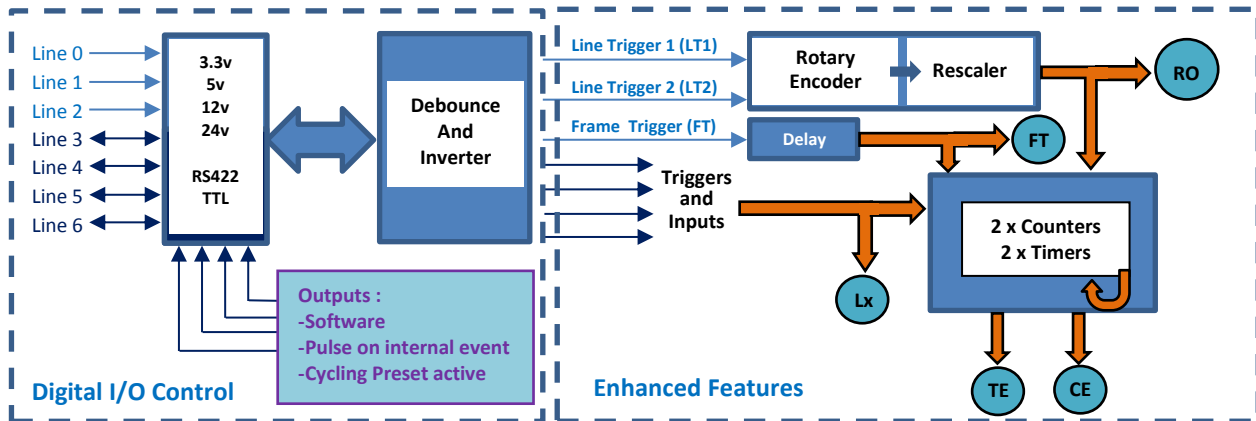

- The Internal Signals provided by the Digital I/O Block and the Enhance Feature block are :
 - LT1/2 : Line Trigger 1/2
 - RO : Rotary Encoder Output
 - FT : Frame Trigger (Signal Issued from the DigitalI/OControl Block)
 - Frame Valid (Signal issued from the Frame Valid GenICam Trigger)
 - Frame Start (Signal issued from the Frame Start GenICam Trigger)
 - FLO (Exposure Active in the Sensor)
 - Lx : Line Inputs (L3, L4, L5, L6)
 - TE1/2 : Timers End 1/2
 - CE1/2 : Counters End 1/2

- Then these Signals will be used to generate the 4 possible GenICam Triggers :
 - Line Start : With Exposure mode Off or Timed and a possible Delay before Exposure.
 - Exposure Active : With Exposure mode in TriggerWidth, linked to the Trigger signal level
 - Frame Start : The Frame Length is fixed and set by “Height” parameter.
 - Frame Active : For a variable Frame Length which depends on the Frame Trigger

- Some other Interesting Features :

- A cycling mode which allows looping over a sequence of up to 8 Steps the 4 Possible Presets of Parameters (Gain, Exposure Time and Delay, FFC, White Balance, Colour Correction Matrix ...)
- Up to 4x Region of Interests with separate FFC can be selected for Output
- Additional Metadata at the end of each Line : Current Exposure Time, Missed Trigger, Current Preset, TimeStamp, Line Counter, Timers and Counters values ...

7 Camera Commands

7.1 Device Control

GenCP address	GenICam Register	Size (Bytes)	R/W	Description
0x00011030	DeviceScanType	4	RO	AreaScan (0) or LineScan (1)
0x0048	DeviceVendorName	32	RO	e2v
0x0068	DeviceModelName	32	RO	NBASE_T_COLOUR
0x00A8	DeviceManufacturerInfo	48	RO	Camera Part Number : EV71C4CNTxxxx-BA0
0x0088	DeviceVersion	32	RO	Camera Firmware Version
0x00D8	DeviceSerialNumber	16	RO	Camera Serial Number : YYWWAxxxx
0x00E8	DeviceUserID	16	RW	Camera ID set by the User
0x11088	DeviceSFNCVersionMajor	4	RO	2
0x1108C	DeviceSFNCVersionMinor	4	RO	0
0x11090	DeviceSFNCVersionSubMinor	4	RO	0
-	DeviceTLVersionMajor	4	RO	2 (mapped on GevVersionMajor)
-	DeviceTLVersionMinor	4	RO	0 (mapped on GevVersionMinor)
-	DeviceLinkSelector	4	RO	1
-	DeviceLinkSpeed	4	RO	625000000
-	DeviceLinkHeartbeatTimeout	4	RW	(5s by default)
-	DeviceLinkCommandTimeout	4	RW	(1s by default)
0x0904	DeviceStreamChannelCount	4	RO	1
-	DeviceStreamChannelType	4	RO	Transmitter (0), Receiver (1)
-	DeviceStreamChannelEndianness	4	RW	Big (0), Little (1)
-	DeviceStreamChannelPacketSize	4	RW	-
0x0900	DeviceEventChannelCount	4	RO	1
-	DeviceCharacterSet	4	RO	ASCII(0), UTF8(1)
-	DeviceRegistersEndianness	4	RO	Big(0), Little(1)
0x4E058098	CameraTemperature	4	RO	Read temperature value of the Device Format : Q10.2 in degree Celsius (-511/512)
0x4E058078	ElectronicBoardID	32	RO	<i>Production info</i>
0x4E05809C	ElectronicBoardTestStatus	32	RO	<i>Production info</i>
0x4E058114	Reboot	4	WO	Command : Set to 1 to reboot the Camera
-	TimeStampReset	4	WO	Command to Reset the TimeStamp
-	TimestampLatch	4	WO	Command to latch the TimeStamp with Custom Value
-	TimestampLatchValue	32	RW	Value to latch the TimeStamp on Command
0x4E060608	ManufacturerIndex	8	RO	Index of production set in Factory
0x4E058110	Status	4	RO	Camera Status : Bit0 to 7 : <i>Reserved</i> Bit8 : Overflow occurs during FFC calibration Bit9 : Underflow occurs during FFC calibration Bit10 : Calibration Error Bit11 : Scan Direction (Forward : 0, Reverse : 1) Bit12 : <i>Reserved</i> Bit14 : Initialization error Bit13 : <i>Reserved</i> Bit15 : Hardware error detected during init
0x4E060644	MissedTriggerCount	4	RO	Missed Triggers Internal Counter

7.2 Image Format Control

This section includes all the settings relative to the Image Format and size.

7.2.1 Image Format

- **Height** : Set the Height of the Image, but also the Buffer's Heights in the Application. From 1 to 16383
- **Test Image Selector** : Test Patterns are defined in Appendix A
- **Reverse Reading** : Reverse output the line in the "X" Direction.
- **Sensor Mode** : Depends on the camera Sensor version : Full Definition for 4k and True Color for 2k.
- **Scan Direction** : Defines the if the Standard web direction is forward or Reverse versus the Mounting of the camera in the System. If Set on External, it is defined by the **Scan Direction Source** Signal (0:Forward, 1:Reverse) :

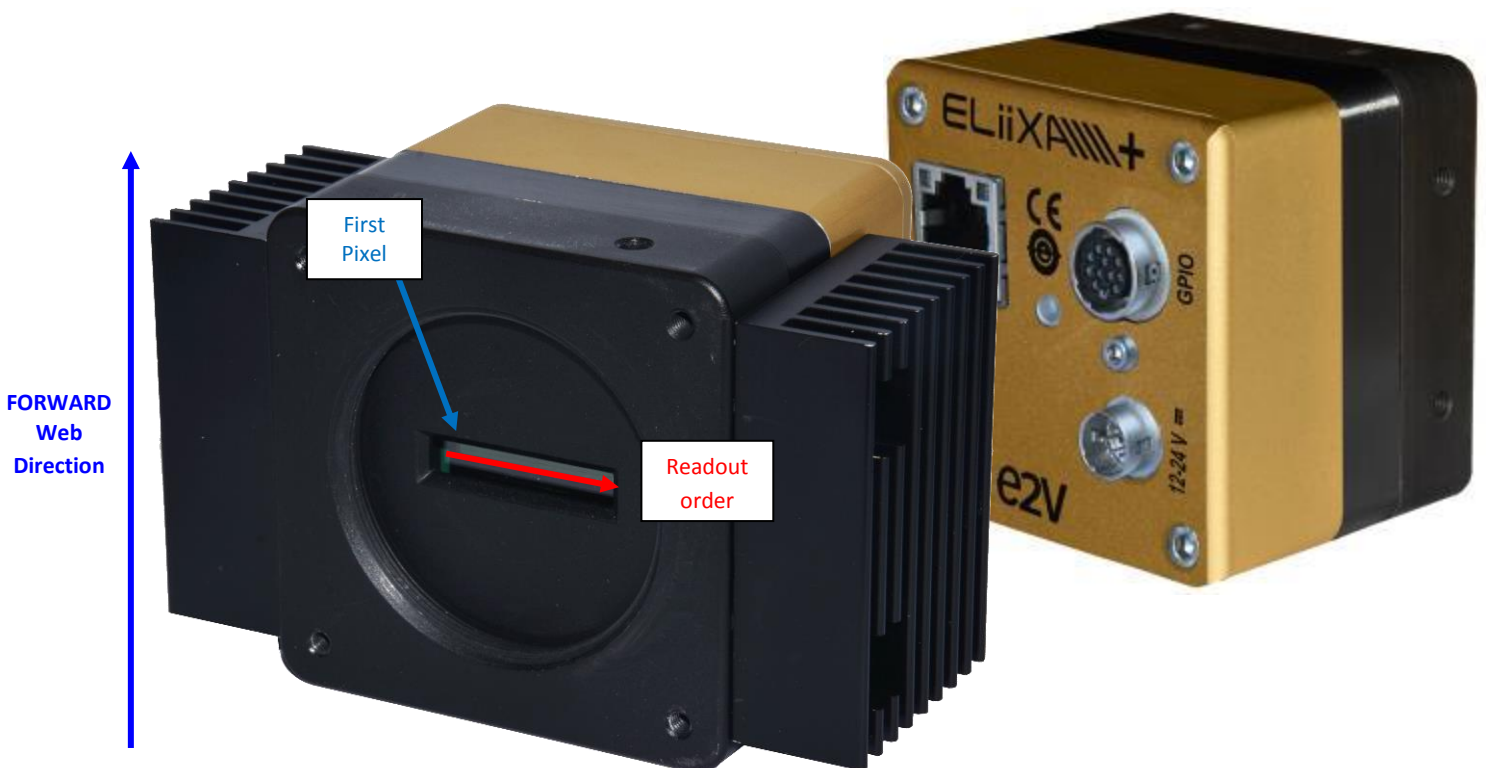

The Scan direction information is available and useful only for the 4k version as green and Blue/Red Lines information are grabbed separately and then the grabbing direction makes sense.

7.2.2 Meta Data

When enabled, Meta Data are added at the End of Each Line for a total of 24 Bytes (Equivalent of 8 RGB Pixels). In the table below :

M0/M1/M2 are the R/G/B components of the First Pixel

...

M21/M22/M23 are the R/G/B components of the 8th Pixel

Pixel n°	Component	Data	Name	Details
1	R = M0	[7:0]	Exposure Time	Value on 2 Bytes. Multiple of 100ns from 0 to 6553,5µs
	G = M1	[15:8]		
	B = M2	[23:16]	Missed Trigger	Bit2 (D18) set to 1. Reset by Register
2	R = M3	[31:24]	Current Cycling Preset	Bit(1:0) : Value of the cycling Preset in Use
	G = M4	[39:32]	Line Counter Value	Line Number (Counter). Reset by register. Integer value on 4 Bytes : 0 to 2 ³² -1
	B = M5	[47:40]		
3	R = M6	[55:48]		
	G = M7	[63:56]	Counter 1 Value	16 LSB of the Counter 1 Value
	B = M8	[71:64]		
4	R = M9	[79:72]	Counter 2 Value	16 LSB of the Counter 2 Value
	G = M10	[87:80]		
	B = M11	[95:88]		
5	R = M12	[103:96]	Timer 1 Value	16 LSB of the Timer 1 Value
	G = M13	[111:104]		
	B = M14	[119:112]	Timer 2 Value	16 LSB of the Timer 2 Value
6	R = M15	[127:120]		
	G = M16	[135:128]	TimeStamp Value	Universal Time counter in milliseconds. Reset by Register. Value from 0 to 2 ⁶⁴ -1
	B = M17	[143:136]		
7	R = M18	[154:144]		
	G = M19	[159:152]		
	B = M20	[167:160]		
8	R = M21	[175:168]	TimeStamp Value	Universal Time counter in milliseconds. Reset by Register. Value from 0 to 2 ⁶⁴ -1
	G = M22	[183:176]		
	B = M23	[191:184]		

7.2.3 Regions of Interest

Up to 4 Regions of Interest can be set :

- No Overlap is possible between the different ROI : Start and width defined for each ROI.
- Each ROI will perform its own Flat Field Correction (Max reference taken in the ROI).
Example with 3 ROI on a “Film Scanning” Image :

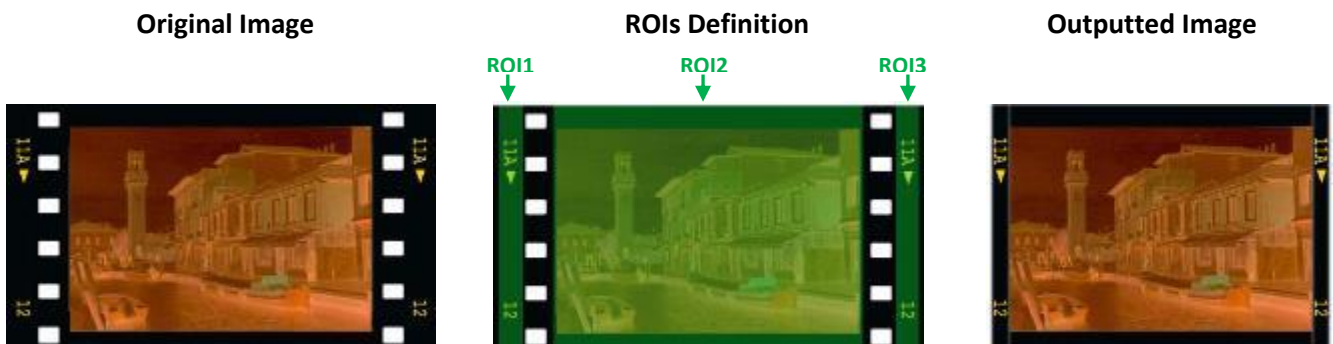

GenCP address	GenICam Register	Size (Bytes)	R/W	Description
0x12500	SensorWidth	4	RO	Active Pixels number of the Sensor
0x12500	Width	4	RO	Total Pixels number outputted including MetaData
0x12510	Height	4	RW	Set the Height of the image (1 to 16383)
0x12540	PixelFormat	4	RO	RGB8
-	PixelSize	4	RO	Bpp24(9) : 24bits RGB Pixel
-	PixelColorFilter	4	RO	None(0)
0x4E058074	TestImageSelector	4	RW	0 : "Off" (Sensor image) 1 : "GreyHorizontalRamp" 2 : "whitePattern" 3 : "GrayPattern" 4 : "BlackPattern" 5 : "GreyVerticalRampMoving"
0x4E058118	ReverseReading	4	RW	0 : disable 1 : enable
0x4E058068	SensorMode	4	RW	Depending the model of the camera 0 : Full Definition Single (4k Model) 1 : True Color Single (2k Model) 2 : Full definition Enhance (4k Model) 3 : True Color Enhance (2k Model)
0x4E05806C	InputSource	4	RO	"Cmos Sensor Processing Chain ON"
0x4E058070	ScanDirection	4	RW	Set/Get Scan Direction (forward or reverse) 0: Forward 1: Reverse 2: Externally controlled o External Signal=0: Forward o External Signal =1: Reverse
0x4E058528	ScanDirectionSource	4	RW	Source for the External control of the Scan Direction : 0 : Line Trigger 1 (LT1) 1 : Line Trigger 2 (LT2) 2 : Frame Trigger (FT) 3 : L3 4 : L4 5 : L5 6 : L6
0x4E058398	MetaDataMode	4	RW	Meta Data Added at the end of each Line : 0 : disable 1 : enable
Regions of Interest				
0x4E0582CC	ROI_Number	4	RW	Set the number of ROI : 0 : No ROI. Default output is the full Sensor Width 1 to 4 : 1 to 4 ROI with no possible Overlap
-	ROISelector			ROI1 to ROI4
0x4E0582D4	ROI1_Start	4	RW	Set the Pixel Start of ROI1 (0 to SensorWidth-1)
0x4E0582D0	ROI1_Width	4	RW	Set the Pixel Width of ROI1 (0 to SensorWidth-1)
0x4E0582E4	ROI2_Start	4	RW	Set the Pixel Start of ROI2 (0 to SensorWidth-1)
0x4E0582D8	ROI2_Width	4	RW	Set the Pixel Width of ROI2 (0 to SensorWidth-1)
0x4E0582E8	ROI3_Start	4	RW	Set the Pixel Start of ROI3 (0 to SensorWidth-1)
0x4E0582DC	ROI3_Width	4	RW	Set the Pixel Width of ROI3 (0 to SensorWidth-1)
0x4E0582EC	ROI4_Start	4	RW	Set the Pixel Start of ROI4 (0 to SensorWidth-1)
0x4E0582E0	ROI4_Width	4	RW	Set the Pixel Width of ROI4 (0 to SensorWidth-1)

7.3 Transport Layer Control

These are the standard and required parameters for the Ethernet Transport Layer.

GenCP address	GenICam Register	Size (Bytes)	R/W	Description
0x200134F8	PayLoadSize	4	RO	Payload Size calculated from : PixelFormat x Width x Height
GigE Vision				
0x0968	GevPhysicalLinkConfiguration	4	RW	SingleLink
0x0004	GevCurrentPhysicalLinkConfiguration	4	RO	SingleLink
0x0014	GevSupportedOptionSelector	4	RW	<i>257 Options Listed ...</i>
0x0014	GevSupportedOption	4	RO	Indicates if the selected Option is supported : 0 : False 1 : True
0x0014	GevInterfaceSelector	4	RW	Selects which logical link to control
0x0014	GevMACAddress	4	RO	MAC address of the logical link
0x0014	GevPAUSEFrameReception	4	RW	Controls whether incoming PAUSE Frames are handled on the given logical link : 0: Off 1: On
0x0014	GevCurrentIPConfigurationLLA	4	RW	Enables the Link Local Address IP configuration scheme on the given logical link : 0: Off 1: On
0x0014	GevCurrentIPConfigurationDHCP	4	RW	Enables the DHCP IP configuration on the given logical link : 0: Off 1: On
0x0014	GevCurrentIPConfigurationPersistentIP	4	RW	Enables the PersistentIP configuration scheme on the given logical link : 0: Off 1: On
0x0024	GevCurrentIPAddress	4	RO	Current IP Address
0x0034	GevCurrentSubnetMask	4	RO	Current SubNet Mask
0x0044	GevCurrentDefaultGateway	4	RO	Current Default Getaway
0xA030	GevIPConfigurationStatus	4	RO	Report The IP Configuration Status : 0: None 1 : Persistent IP 2 : DHCP 3 : LLA 4 : Force IP
0x064C	GevPersistentIPAddress	4	RW	Persistent IP Address
0x065C	GevPersistentSubnetMask	4	RW	Persistent SubNet Mask
0x066C	GevPersistentDefaultGateway	4	RW	Persistent Default Getaway
-	GevTimestampTickFrequency	4	RO	
-	GevIEEE1588	4	RW	0: Off 1: On
-	GevIEEE1588ClockAccuracy	4	RW	Accuracy of IEEE 1588 Clock : 0: Within 25ns 1 : Within 100ns 2 : Within 250ns 3 : Within 1µs 4 : Within 2.5µs 5 : Within 10µs

				6 : Within 25µs 7 : Within 100µs 8 : Within 250µs 9 : Within 1ms 10 : Within 2.5ms 11 : Within 10ms 12 : Within 25ms 13 : Within 100ms 14 : Within 250ms 15 : Within 1s 16 : Within 10s 17 : Greater than 10s 18 : Alternate PT Profile 19 : <i>Unknown</i> 20 : <i>Reserved</i>
0x096C	GevIEEE1588Status	4	RO	Status of IEEE 1588 Clock : 0: Initializing 1 : Faulty 2 : Disabled 3 : Listening 4 : Pre Master 5 : Master 6 : Passive 7 : Uncalibrated 8 : Slave
-	GevGVCPExtendedStatusCodesSelector	4	RW	Version 1_1
-	GevGVCPExtendedStatusCodes	4	RW	Enables the generation of extended status codes : 0: False 1 : On
-	GevGVCPPendingAck	4	RW	Enables the generation of PENDING_ACK : 0: False 1 : True
0x0960	GevGVSPExtendedIDMode	4	RW	Enables the extended IDs mode : 0: Off 1 : True
0x0A00	GevCCP	4	RW	Controls the device access privilege of an application : 0: Open Access 1 : Exclusive Access 2: Control Access
0x0A04	GevPrimaryApplicationSocket	4	RO	UDP source port of the primary application
0x0A14	GevPrimaryApplicationIPAddress	4	RO	Address of the primary application
0x0B00	GevMCPHostPort	4	RW	Port to which the device must send messages
0x0B10	GevMCDA	4	RW	Destination IP address for the message channel
0x0B14	GevMCTT	4	RW	Transmission timeout value in milliseconds
0x0B18	GevMCRC	4	RW	Number of retransmissions allowed when a message channel message times out
0x0B1C	GevMCSP	4	RO	Indicates the source port for the message channel
-	GevStreamChannelSelector		WO	Selects the stream channel to control
0x0D24	GevSCCFGUnconditionalStreaming	4	RW	Forces the Stream even if the Channel is closed : 0: False 1 : True
0x0D24	GevSCCFGExtendedChunkData	4	RW	Enables cameras to use the extended chunk data payload type for this stream channel : 0: False 1 : True
0x0D00	GevSCPIInterfaceIndex	4	RW	Index of the logical link to use

0x0D00	GevSCPHostPort	4	RW	Controls the port of the selected channel to which a GVSP transmitter must send data stream
0x0D04	GevSCPSFireTestPacket	4	RW	Sends a test packet 0: Off 1: On
0x0D04	GevSCPSDoNotFragment	4	RW	Used by the application to prevent IP fragmentation of packets on the stream channel : 0: Off 1: On
0x0D08	GevSCPD	4	RW	Delay (in GEV timestamp counter unit) to insert between each packet for this stream channel
0x0D18	GevSCDA	4	RW	Destination IP address of the selected stream channel to which a GVSP transmitter must send data stream
0x0D1C	GevSCSP	4	RO	Indicates the source port of the stream channel
0x19010	GevStreamThroughputLimit	4	RW	Limits the peak bit rate in Mbps to be streamed out on the selected stream channel.

7.4 Acquisition Control

7.4.1 GenICam Triggers

Four GenICam Triggers can be configured :

- Line Start Trigger : Start the Line on an Edge variation of the Source
- Exposure Active Trigger : Exposure active on a certain Level of the Source
- Frame Start Trigger : Start the Frame on an Edge variation of the Source
- Frame Active Trigger : Frame active on a certain Level of the Source

Each Trigger has these 5 following parameters :

- Trigger Mode : Activates the Trigger. Only one Line and Frame Trigger activated in the same time.
- Trigger Source : Defines the Signal which is the Source of the Trigger (see table below)
- Trigger activation : Defines how the Source activate the Trigger (on edge for Line Start and Frame Start or level for Exposure Active and Frame Active)
- TriggerMaskSource : Defines the signal that can be set to enable/disable the Trigger
- TriggerMaskActivation : Defines on which level the TriggerMaskSource is activated.

All the following External / Internal Signals are used for the Trigger Sources or Masks :

Signal	Value	Trigger Sources				Trigger Masks			
		Line Start	Exp. Active	Frame Start	Fr. Active	Line Start	Exp. Active	Frame Start	Fr. Active
Off	0	-	-	-	-	√	√	√	√
Line Trigger 1	1	√	√	-	-	-	-	-	-
Line Trigger 2	2	√	√	-	-	-	-	-	-
Frame Trigger	3	-	-	√	√	-	-	-	-
FLO (Exposure Active)	4	-	-	-	-	√	√	√	√
Counter 1 End	5	√	√	√	√	√	√	√	√
Counter 2 End	6	√	√	√	√	√	√	√	√
Timer 1 End	7	√	√	√	√	√	√	√	√
Timer 2 End	8	√	√	√	√	√	√	√	√
L3	9	-	-	-	-	√	√	√	√
L4	10	-	-	-	-	√	√	√	√
L5	11	-	-	-	-	√	√	√	√
L6	12	-	-	-	-	√	√	√	√
Frame Valid	13	-	-	-	-	√	√	√	√
Acquisition Active	14	-	-	-	-	√	√	√	√
Software	15	-	-	√	√	√	√	√	√
Rotary Enc. Output	16	√	√	-	-	-	-	-	-

GenCP address	GenICam Register	Size (Bytes)	R/W	Description
0x13100	AcquisitionMode	4	RW	0: Continuous 1: Single Frame 2: Multi Frame 3: Single Frame Recording 4: Single Frame Readout
0x13110	AcquisitionStart	4	WO	Command : Not readable
0x13120	AcquisitionStop	4	WO	Command : Not readable
0x20013438	AcquisitionFrameCount	4	RW	Number of Frame to Acquire in "Multi Frame" Acquisition Mode : from 1 to 255
0x4E0581D4	ExposureTime	4	RW	Exposure Time for Preset 1 and default : From 1 to 65535 by Step of 0.1µs
0x4E05843C	LinePeriod	4	RW	Line Period (Internal Trigger Modes Only)
0x4E0581D8	LinePeriodMin	4	RO	Minimum Line Period possible
0x4E058358	ExposureDelay	4	RW	Exposure Delay for Preset 1 and default. From 0 to 65535 by Step of 0.1µs
0x4E0581BC	ExposureTime_PR2	4	RW	Exposure Time for Preset 2. From 1 to 65535 by Step of 0.1µs
0x4E058384	ExposureDelay_PR2	4	RW	Exposure Delay for Preset 2. From 0 to 65535 by Step of 0.1µs
0x4E0581C0	ExposureTime_PR3	4	RW	Exposure Time for Preset 3. From 1 to 65535 by Step of 0.1µs
0x4E058388	ExposureDelay_PR3	4	RW	Exposure Delay for Preset 3. From 0 to 65535 by Step of 0.1µs
0x4E0581C4	ExposureTime_PR4	4	RW	Exposure Time for Preset 4. From 1 to 65535 by Step of 0.1µs
0x4E05838C	ExposureDelay_PR4	4	RW	Exposure Delay for Preset 4. From 0 to 65535 by Step of 0.1µs
0x4E058520	LineTriggerTimeout	4	RW	TimeOut to consider the Line Trigger as missing (in ms)
Triggers				
0x4E05851C	ExposureMode	4	RW	0: Off 1: Timed 2: Trigger Width
0x4E058494	FrameTriggerSoftware	4	RW	Control the Frame Trigger (if Software enabled)
	TriggerSelector			0: Line Start, 1: Exposure Active, 2: Frame Start, 3: Frame Active
0x4E05849C	TriggerMode_LineStart	4	RW	Validation of the Line Trigger Start (disabled if the Exposure Active Trigger is enabled): 0: Off 1: On
0x4E058340	TriggerSource_LineStart	4	RW	Source for the Line Start Trigger: 1: Line Trigger 1 2: Line Trigger 2 5: Counter 1 End 6: Counter 2 End 7: Timer 1 End 8: Timer 2 End 16: Rotary Encoder Output
0x4E058350	TriggerActivation_LineStart	4	RW	Activation of Line Start Trigger : 0: Rising Edge 1: Falling Edge
0x4E06063C	TriggerMaskActivation_LineStart	4	RW	Activation of Trigger Mask for Line Start Trigger : 3: Level High 4: Level Low
0x4E060634	TriggerMaskSource_LineStart	4	RW	Source for the Trigger Mask for Line Start Trigger :

				0 : Off (The Trigger Mask is disabled) 4 : FLO (Exposure Active in the Sensor) 5 : Counter 1 End 6 : Counter 2 End 7 : Timer 1 End 8 : Timer 2 End 9 : L3 10 : L4 11 : L5 12 : L6 13 : Frame Valid 14 : Acquisition Active
0x4E060610	TriggerMode_ExposureActive	4	RW	Validation of the Exposure Active Trigger (disabled if the Line Start Trigger is enabled): 0 : Off 1 : On
0x4E060618	TriggerSource_ExposureActive	4	RW	Source for the Exposure Active Trigger : 1 : Line Trigger 1 2 : Line Trigger 2 5 : Counter 1 End 6 : Counter 2 End 7 : Timer 1 End 8 : Timer 2 End 16 : Rotary Encoder Output
0x4E060614	TriggerActivation_ExposureActive	4	RW	Activation of Exposure Active Trigger : 3 : Level High 4 : Level Low
0x4E060628	TriggerMaskActivation_ExposureActive	4	RW	Activation of Trigger Mask for Exposure Active Trigger : 3 : Level High 4 : Level Low
0x4E060624	TriggerMaskSource_ExposureActive	4	RW	Source for the Trigger Mask for Exposure Active Trigger : 0 : Off (The Trigger Mask is disabled) 4 : FLO (Exposure Active in the Sensor) 5 : Counter 1 End 6 : Counter 2 End 7 : Timer 1 End 8 : Timer 2 End 9 : L3 10 : L4 11 : L5 12 : L6 13 : Frame Valid 14 : Acquisition Active
0x4E0584A0	TriggerMode_FrameStart	4	RW	Validation of the Frame Start Trigger (disabled if the Frame Trigger Active is enabled) 0 : Off 1 : On
0x4E058344	TriggerSource_FrameStart	4	RW	Source for the Frame Start Trigger : 3 : Frame Trigger 5 : Counter 1 End 6 : Counter 2 End 7 : Timer 1 End 8 : Timer 2 End 15 : Software
0x4E058354	TriggerActivation_FrameStart	4	RW	Activation of the Frame Start Trigger on the Edge : 0 : Rising Edge 1 : Falling Edge
0x4E060640	TriggerMaskActivation_FrameStart	4	RW	Activation of Trigger Mask for Frame Start Trigger : 3 : Level High 4 : Level Low
0x4E060638	TriggerMaskSource_FrameStart	4	RW	Source for the Trigger Mask for Frame Start Trigger : 0 : Off 4 : FLO (Exposure Active in the Sensor)

				5 : Counter 1 End 6 : Counter 2 End 7 : Timer 1 End 8 : Timer 2 End 9 : Line 3 10 : Line 4 11 : Line 5 12 : Line 6 13 : Frame Valid 14 : Acquisition Active
0x4E058498	TriggerMode_FrameActive	4	RW	Validation of the Frame Active Trigger (disabled if the Frame Trigger Start is enabled) 0 : Off 1 : On
0x4E058348	TriggerSource_FrameActive	4	RW	Source for the Frame Trigger Active : 3 : Frame Trigger 5 : Counter 1 End 6 : Counter 2 End 7 : Timer 1 End 8 : Timer 2 End 15 : Software
0x4E05834C	TriggerActivation_FrameActive	4	RW	Activation of the Frame Active on the level : 3 : Level High 4 : Level Low
0x4E060630	TriggerMaskActivation_FrameActive	4	RW	Activation of Trigger Mask for Frame Active Trigger : 3 : Level High 4 : Level Low
0x4E06062C	TriggerMaskSource_FrameActive	4	RW	Source for the Trigger Mask for Frame Active Trigger : 0 : Off 4 : FLO (Exposure Active in the Sensor) 5 : Counter 1 End 6 : Counter 2 End 7 : Timer 1 End 8 : Timer 2 End 9 : L3 10 : L4 11 : L5 12 : L6 13 : Frame Valid 14 : Acquisition Active

7.4.2 Cycling Preset modes and configuration

The Cycling Preset mode is the possibility for the camera to switch at least for each line between 4x sets of pre-defined parameters including :

- Exposure Time and Exposure Delay
- Flat Field Correction
- Gain (Amplification Gain)
- White Balance Gains
- RGB Colour Correction Matrix

The Cycling Preset mode configuration allows up to 8 different steps for switching between this choice of 4 sets of parameters and thus with the arising of different possible events (Line Input, Line Trigger, Frame Trigger, end of Counter and/or Timer ...) :

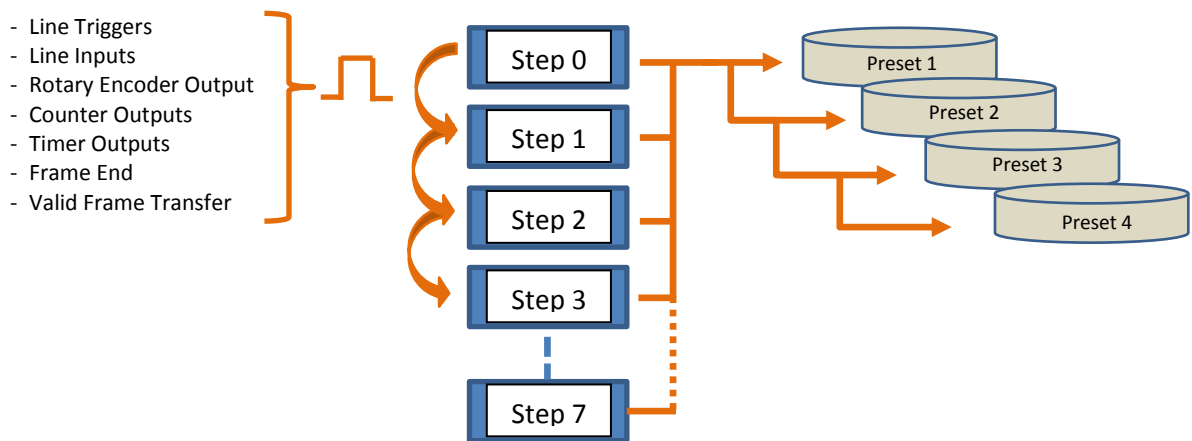

If the Cycling mode is disabled or the number of configuration used (CyclingPresetCount) set to 1 or if the number of Repeater (CyclingPresetRepeaterNumber) is set to 1, then all these configuration are equivalent to the use of one single Preset which is the default one : **Preset 1**.

GenCP address	GenICam Register	Size (Bytes)	R/W	Description
0x4E0581DC	CyclingPresetMode	4	RW	Activation of the Cycling Preset Mode : 0 : Off 1 : On
-	CyclingPresetSelector	4	RW	Selects the Cycling Preset to save the automatic FFC Calibrations : 1 : Preset 1 2 : Preset 2 4 : Preset 3 8 : Preset 4 15 : All Presets
0x4E0581E4	CyclingPresetSource	4	RW	Signal Source for the Changing of Preset : 1 : Line Trigger 1 2 : Line Trigger 2 5 : Counter 1 End 6 : Counter 2 End 7 : Timer 1 End 8 : Timer 2 End 9 : L3 10 : L4 11 : L5 12 : L6 13 : Frame Valid 16 : Rotary Encoder
0x4E0581E0	CyclingPresetCount	4	RW	Number of Configuration setting used (From 2 to 4) :

				2 : Preset 1 and 2 are used 3 : Preset 1, 2 and 3 are used 4 : Preset 1, 2, 3 and 4 are used
0x4E058210	CyclingPresetEdge	4	RW	Activation Edge for the next repeater: 0 : Falling Edge 1 : Rising Edge
0x4E0581E8	CyclingPresetSynchronization	4	RW	Restart Cycling Sequence from Repeater 0 at : 0 : Next Line 1 : Next Frame 2 : Software (Use "Manual Change")
0x4E05820C	CyclingPresetRepeaterNumber	4	RW	Number of Repeater in the Cycling loop : from 1 to 8
0x4E0581F8	CyclingPresetRepeater0	4	RW	Choice of the Preset for the Repeater 0 : 0 : Preset 1 1 : Preset 2 2 : Preset 3 (if CyclingPresetCount > 2) 3 : Preset 4 (if CyclingPresetCount =4)
0x4E0581EC	CyclingPresetRepeater1	4	RW	Choice of the Preset for the Repeater 1 : 0 : Preset 1 1 : Preset 2 2 : Preset 3 (if CyclingPresetCount > 2) 3 : Preset 4 (if CyclingPresetCount =4)
0x4E0581F0	CyclingPresetRepeater2	4	RW	Choice of the Preset for the Repeater 2 : 0 : Preset 1 1 : Preset 2 2 : Preset 3 (if CyclingPresetCount > 2) 3 : Preset 4 (if CyclingPresetCount =4)
0x4E0581F4	CyclingPresetRepeater3	4	RW	Choice of the Preset for the Repeater 3 : 0 : Preset 1 1 : Preset 2 2 : Preset 3 (if CyclingPresetCount > 2) 3 : Preset 4 (if CyclingPresetCount =4)
0x4E0581FC	CyclingPresetRepeater4	4	RW	Choice of the Preset for the Repeater 4 : 0 : Preset 1 1 : Preset 2 2 : Preset 3 3 : Preset 4
0x4E058200	CyclingPresetRepeater5	4	RW	Choice of the Preset for the Repeater 5 : 0 : Preset 1 1 : Preset 2 2 : Preset 3 (if CyclingPresetCount > 2) 3 : Preset 4 (if CyclingPresetCount =4)
0x4E058204	CyclingPresetRepeater6	4	RW	Choice of the Preset for the Repeater 6 : 0 : Preset 1 1 : Preset 2 2 : Preset 3 3 : Preset 4
0x4E058208	CyclingPresetRepeater7	4	RW	Choice of the Preset for the Repeater 7 : 0 : Preset 1 1 : Preset 2 2 : Preset 3 (if CyclingPresetCount > 2) 3 : Preset 4 (if CyclingPresetCount =4)
0x4E058490	CyclingPresetManualChange	4	RO	Command to change of Preset Choice of the Preset for the Repeater : 0 : Preset 1 1 : Preset 2 2 : Preset 3 (if CyclingPresetCount > 2) 3 : Preset 4 (if CyclingPresetCount =4)

7.4.3 Full Exposure Control Mode (4k Full Definition Enhanced only)



The Full Exposure Control

In Full Definition Enhanced Sensor Mode, the Sensor is working as a double TDI (Time Integration Delay) : The two Top Pixels and the two bottom Pixels are working together in TDI with a delay between their exposure and outputting by the same Memory node and ADC. The summation of the pixels is done in the “charge domain” before the Digital Conversion.

This is the case for the ELIIXA+ 4k in Full Definition Enhanced Mode only

In TDI, control of the exposure is not possible: Only the full Exposure during the Line Period is possible. In order to allow the User to control the exposure in this Sensor mode (Synchronization Modes 1 and 3, described in the Acquisition control chapter), The ELIIXA+ Camera implement a “Full Exposure Control Mode” :

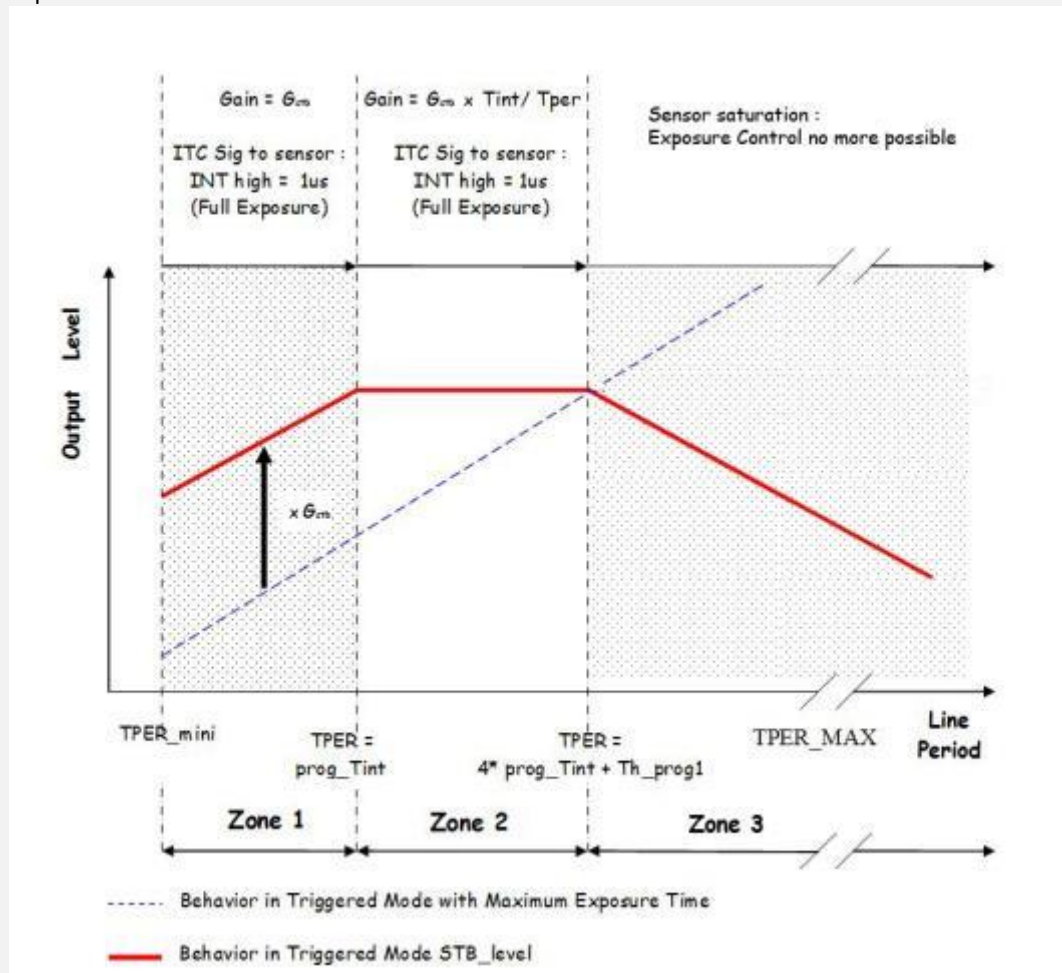

When the User selects a synchronization mode which requires the control of the exposure, the camera enters a specific mode:

The Line Period (measured) is $Tper$, its minimum value is $TPer_{mini}$ ($10\mu s$ on this camera) and the exposure time set by the User is $Prog_Tint$.

Zone 1 : If $Tper < Prog_Tint$

Not relevant. $Prog_Tint$ has to be smaller than $Tper$. **The Camera can't be use in that area**

Zone 2 : If $Tper < 4 \times \text{Max}(TPer_{mini}, Prog_Tint) + 10\mu s$

The Sensor works in Full Exposure during the whole Line Period (LP) and the gain applied on the output is variable (max x 4), set by User = G_{stb}

The Output is multiplied by the following Gain = $G_{stb} \times Prog_Tint / Tper$

Zone 3 : If $T_{per} \geq 4 \times \text{Max}(T_{Per}_{\text{mini}}, \text{Prog_Tint}) + 10\mu\text{s}$

The risk is the sensor saturates then the calculation above is no more valid : after showing an incorrect white balance, the image level will decrease down to 0 as the Line Period is increasing.

=> **The Camera can't be use in that area**

Gain for the “Full Exposure Control Mode” (See “Gain & Offset” Section below : *StabilizedGain*)

G_{stb} : The User Can set this Gain with a value up to x4 (Gain Section). The value recommended is the one which allows to cover the variation of the line period : 10% of variation requires a Gain at least of x1.2 (+/- 10%).

By default this value is set at x4.

**Trigger too Slow : Line Trigger Timeout**

By default, the trigger is considered too slow after 1000ms of missing Incoming Trigger.

This limit can be tuned now by the User. This tuning is particularly important when the camera is in **Full Definition Enhanced** (4k) with the **Exposure control active** : In this mode (Full Exposure Control) the incoming Line Period is delayed from one line to be reproduced in the camera after an exact measurement of the Line Period. If the trigger stops for a period of time below the limit, this will be considered as a “long time Line” and not a stop : Then the next line will be delayed from the same value with the risk to lose new incoming triggers.

The Line Trigger Timeout limit has to be set at a value which is considered in the Application as the minimum value for a real stop in the incoming trigger.

7.5 Digital I/O Control

This Digital I/O Module allows to setup and transformed the 7 I/O Lines of the I/O Connector in useful internal signals :

- Line 0, 1 and 2 are preferred inputs (only inputs) to set the three internal Signals : Line Trigger 1 and 2 (LT1, LT2) and Frame Trigger (FT)
- Line 3, 4, 5 and 6 can be configured in additional inputs (for the generation of L3, L4, L5 and L6 internal Signals) as well as in dedicated Outputs

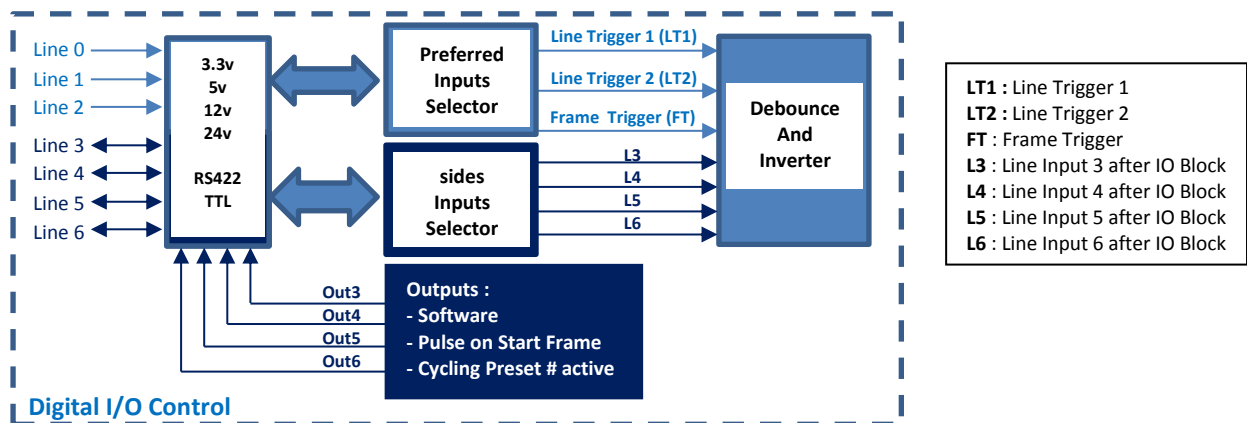

GenCP address	GenICam Register	Size (Bytes)	R/W	Description
Line Mode				
0x4E058268	LineMode_L0	4	RO	0 : Input only
0x4E05826C	LineMode_L1	4	RO	0 : Input only
0x4E058270	LineMode_L2	4	RO	0 : Input only
0x4E058274	LineMode_L3	4	RW	Set the line mode : 0 : Input 1 : Output
0x4E058278	LineMode_L4	4	RW	Set the line mode : 0 : Input 1 : Output
0x4E05827C	LineMode_L5	4	RW	Set the line mode : 0 : Input 1 : Output
0x4E058280	LineMode_L6	4	RW	Set the line mode : 0 : Input 1 : Output
Line Status				
0x4E0582F0	LineStatusInvisible	4	RO	Value of each I/O Line :
-	Bit 0	-	-	Status Line 0
-	Bit 1	-	-	Status Line 1
-	Bit 2	-	-	Status Line 2
-	Bit 3	-	-	Status Line 3
-	Bit 4	-	-	Status Line 4
-	Bit 5	-	-	Status Line 5
-	Bit 6	-	-	Status Line 6

GenCP address	GenICam Register	Size (Bytes)	R/W	Description
Input Lines				
Internal Signals Source				
0x4E0582F4	IOSource_LT1	4	RW	Select the Source for Line Trigger 1 (LT1) : <ul style="list-style-type: none"> • Line0 • Line1 • Line2
0x4E0582F8	IOSource_LT2	4	RW	Select the Source for Line Trigger 2 (LT2) : <ul style="list-style-type: none"> • Line0 • Line1 • Line2
0x4E0582FC	IOSource_FT	4	RW	Select the Source for Frame Trigger (FT) : <ul style="list-style-type: none"> • Line0 • Line1 • Line2
0x4E0584D8	IOSource_L3	4	RW	Select the Source for L3 (when set as input) : <ul style="list-style-type: none"> • Line3 • Line4 • Line5 • Line6
0x4E0584DC	IOSource_L4	4	RW	Select the Source for L4 (when set as input) : <ul style="list-style-type: none"> • Line3 • Line4 • Line5 • Line6
0x4E0584E0	IOSource_L5	4	RW	Select the Source for L5 (when set as input) : <ul style="list-style-type: none"> • Line3 • Line4 • Line5 • Line6
0x4E0584E4	IOSource_L6	4	RW	Select the Source for L6 (when set as input) : <ul style="list-style-type: none"> • Line3 • Line4 • Line5 • Line6
Line Debouncer				
0x4E05830C	DebouncerPeriod_LT1	4	RW	Set the Debounce time for Line Trigger 1 Input : 0 : disabled 1-65536 : Debounce filter time in in μ s
0x4E058310	DebouncerPeriod_LT2	4	RW	Set the Debounce time for Line Trigger 1 Input : 0 : disabled 1-65536 : Debounce filter time in in μ s
0x4E058314	DebouncerPeriod_FT	4	RW	Set the Debounce time for Frame Trigger Input : 0 : disabled 1-65536 : Debounce filter time in in μ s
0x4E058504	DebouncerPeriod_L3	4	RW	Set the Debounce time for L3 when set as Input : 0 : disabled 1-65536 : Debounce filter time in in μ s
0x4E058508	DebouncerPeriod_L4	4	RW	Set the Debounce time for L4 when set as Input : 0 : disabled 1-65536 : Debounce filter time in in μ s
0x4E05850C	DebouncerPeriod_L5	4	RW	Set the Debounce time for L5 when set as Input : 0 : disabled 1-65536 : Debounce filter time in in μ s
0x4E058510	DebouncerPeriod_L6	4	RW	Set the Debounce time for L6 when set as Input : 0 : disabled 1-65536 : Debounce filter time in in μ s

Line Inverter				
0x4E0584E8	LineInverter_LT1	4	RW	Invert the Line Trigger 1 Signal : 0 : Off 1 : On
0x4E0584EC	LineInverter_LT2	4	RW	Invert the Line Trigger 2 Signal : 0 : Off 1 : On
0x4E0584F0	LineInverter_FT	4	RW	Invert the Line Frame Trigger Signal : 0 : Off 1 : On
0x4E0584F4	LineInverter_L3	4	RW	Invert the L3 Signal (when set as input) : 0 : Off 1 : On
0x4E0584F8	LineInverter_L4	4	RW	Invert the L4 Signal (when set as input) : 0 : Off 1 : On
0x4E0584FC	LineInverter_L5	4	RW	Invert the L5 Signal (when set as input) : 0 : Off 1 : On
0x4E058500	LineInverter_L6	4	RW	Invert the L6 Signal (when set as input) : 0 : Off 1 : On

GenCP address	GenICam Register	Size (Bytes)	R/W	Description
Line Detection				
0x4E0582A0	LineDetectionLevel_L0	4	RW	Set the detection Level of the Line 0 : 0 : 3.3V 1 : 5V 2 : 12V 3 : 24V
0x4E0582A4	LineDetectionLevel_L1	4	RW	Set the detection Level of the Line 1 : 0 : 3.3V 1 : 5V 2 : 12V 3 : 24V
0x4E0582A8	LineDetectionLevel_L2	4	RW	Set the detection Level of the Line 2 : 0 : 3.3V 1 : 5V 2 : 12V 3 : 24V
0x4E0582AC	LineDetectionLevel_L3	4	RW	Set the detection Level of the Line 3 when set as input : 0 : 3.3V 1 : 5V 2 : 12V 3 : 24V
0x4E0582B0	LineDetectionLevel_L4	4	RW	Set the detection Level of the Line 4 when set as input : 0 : 3.3V 1 : 5V 2 : 12V 3 : 24V
0x4E0582B4	LineDetectionLevel_L5	4	RW	Set the detection Level of the Line 5 when set as input : 0 : 3.3V 1 : 5V 2 : 12V 3 : 24V
0x4E0582B8	LineDetectionLevel_L6	4	RW	Set the detection Level of the Line 6 when set as input : 0 : 3.3V 1 : 5V 2 : 12V 3 : 24V
Line Format				
0x4E058284	LineFormat_L0	4	RW	Set the Format of the Line 0 : 0 : Single End 1 : RS422 Without Termination 2 : RS422 With Termination
0x4E058288	LineFormat_L1	4	RW	Set the Format of the Line 1 : 0 : Single End 1 : RS422 Without Termination 2 : RS422 With Termination
0x4E05828C	LineFormat_L2	4	RW	Set the Format of the Line 2 : 0 : Single End 1 : RS422 Without Termination 2 : RS422 With Termination
0x4E058290	LineFormat_L3	4	RW	Set the Format of the Line 3 when set as input : 0 : Single End 1 : RS422 Without Termination 2 : RS422 With Termination
0x4E058294	LineFormat_L4	4	RW	Set the Format of the Line 4 when set as input : 0 : Single End 1 : RS422 Without Termination 2 : RS422 With Termination
0x4E058298	LineFormat_L5	4	RW	Set the Format of the Line 5 when set as input : 0 : Single End 1 : RS422 Without Termination 2 : RS422 With Termination
0x4E05829C	LineFormat_L6	4	RW	Set the Format of the Line 6 when set as input : 0 : Single End 1 : RS422 Without Termination 2 : RS422 With Termination

GenCP address	GenICam Register	Size (Bytes)	R/W	Description
Output Lines				
Line Output Level				
0x4E0582BC	LineOutputLevel_L3	4	RW	Set Line 3 Output Level: 0 : 3.3V 1 : 5V 2 : Power (defined by the Voltage supplied to the Camera)
0x4E0582C0	LineOutputLevel_L4	4	RW	Set Line 4 Output Level: 0 : 3.3V 1 : 5V 2 : Power (defined by the Voltage supplied to the Camera)
0x4E0582C4	LineOutputLevel_L5	4	RW	Set Line 5 Output Level: 0 : 3.3V 1 : 5V 2 : Power (defined by the Voltage supplied to the Camera)
0x4E0582C8	LineOutputLevel_L6	4	RW	Set Line 6 Output Level: 0 : 3.3V 1 : 5V 2 : Power (defined by the Voltage supplied to the Camera)
Activation				
0x4E058360	OutLineSource_Line3	4	RW	Set the Source of Line 3 when set as Output : 0 : Software Controlled 1 : Pulse on Start Frame 2 : Cycling Preset 1 active 3 : Cycling Preset 2 active 4 : Cycling Preset 3 active 5 : Cycling Preset 4 active
0x4E058364	OutLineSource_Line4	4	RW	Set the Source of Line 4 when set as Output : 0 : Software Controlled 1 : Pulse on Start Frame 2 : Cycling Preset 1 active 3 : Cycling Preset 2 active 4 : Cycling Preset 3 active 5 : Cycling Preset 4 active
0x4E058368	OutLineSource_Line5	4	RW	Set the Source of Line 5 when set as Output : 0 : Software Controlled 1 : Pulse on Start Frame 2 : Cycling Preset 1 active 3 : Cycling Preset 2 active 4 : Cycling Preset 3 active 5 : Cycling Preset 4 active
0x4E05836C	OutLineSource_Line6	4	RW	Set the Source of Line 6 when set as Output : 0 : Software Controlled 1 : Pulse on Start Frame 2 : Cycling Preset 1 active 3 : Cycling Preset 2 active 4 : Cycling Preset 3 active 5 : Cycling Preset 4 active
Software Control				
0x4E058370	SoftCtrl_Line3	4	RW	Value for Line 3 Output when controlled by Software
0x4E058374	SoftCtrl_Line4	4	RW	Value for Line 4 Output when controlled by Software
0x4E058378	SoftCtrl_Line5	4	RW	Value for Line 5 Output when controlled by Software
0x4E05837C	SoftCtrl_Line6	4	RW	Value for Line 6 Output when controlled by Software

7.6 Enhanced Features Control

7.6.1 Rotary Encoder, Rescaler and Frame Delay

The Embedded Rotary Encoder is managed by the two inputs Lines :

- LT1 taken as “A” quadrature input
- LT2 taken as “B” quadrature input

The Encoder takes in account the Forward/Reverse indication given to the camera (by software or external input) to determine the forward or Reverse position of the A and B quadrature inputs. Its “Forward/Reverse” outputs is just an indication of its working mode as soon as it is not disabled but has no action on the camera scanning direction.

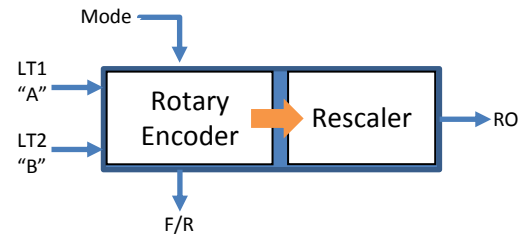

The Output of the Rotary Encoder enters a Rescaler (Multiplier / Divider) that can be also bypassed (neutral).

The Rotary encoder has two working modes :

- Quadratic without miscount : The Encoder is sending only forward lines. Any reverse line is not sent and not counted.
- Quadratic with miscount : The Encoder is sending only forward lines but reverse lines are miscount in an internal counter. The Encoder will restart sending Line triggers as soon as each reverse Line miscounted has been recounted forward.

The Rotary Encoder can be bypassed. Then the “B” input is disabled and the Line Trigger 1 (LT1) connected on input “A” is passing through the Rotary encoder to enter the Rescaler

The Rotary encoder can’t be used by changing the camera operation (Forward/Reverse) “on the fly” as some sensor modes require some reset and some time to change the scanning direction.

GenCP address	GenICam Register	Size (Bytes)	R/W	Description
Rotary Encoder - Rescaler				
0x4E058320	RotaryEncoderOutputMode	4	RW	Disable or Enable the Rotary Encoder : 0 : Rotary Encoder Disabled 1 : One Way Only Count Mode 2 : Back Miscount Mode
0x4E058324	RescalerMultiplier	4	RW	Multiplier Value for Rescaler from 0 to 65535
0x4E058328	RescalerDivider	4	RW	Divider Value for Rescaler from 1 to 65535
0x4E05832C	RotaryEncoderDirection	4	RW	Set the Forward Direction of The Rotary Encoder: 0 : ClockWise 1 : AntiClockWise
0x4E058338	RescalerGranularity	4	RW	Granularity for the Rescaler : 0 : 10 ns 1 : 40 ns 2 : 160 ns 3 : 2560 ns
0x4E05833C	RescalerAverage	4	RW	Number of Last Triggers to Average : 0 : 1 (Averaging disabled) 1 : 2 2 : 4 3 : 8 4 : 16

				5 : 32 6 : 64 7 : 128
0x4E058334	RescalerEnable	4	RW	Enables the Rescaler : 0 : Disabled 1 : Enabled
Frame Trigger Delay Control				
0x4E058318	FrameTriggerDelaySource	4	RW	Number of Last Triggers to Average : 0 : Time Base (μs) 1 : Time Base (ms) 2 : LT1 Rising Edge 3 : LT1 Falling Edge 4 : RO Rising Edge 5 : RO Falling Edge
0x4E05831C	FrameTriggerDelay	4	RW	

7.6.2 Counters & Timers

All the input Signals (Event/Trigger, Reset and Lock) of both Timers and Counters are given in the table below :

Signal	Value	Counter Sources			Timer Sources		
		Event	Reset	Lock	Trigger	Reset	Lock
Off	0	-	✓	✓	-	✓	✓
Line Trigger 1	1	✓	✓	✓	✓	✓	✓
Line Trigger 2	2	✓	✓	✓	✓	✓	✓
Frame Trigger	3	✓	✓	✓	✓	✓	✓
FLO (Exposure Active)	4	✓	-	✓	-	-	✓
Counter 1 End	5	✓	✓	✓	✓	✓	✓
Counter 2 End	6	✓	✓	✓	✓	✓	✓
Timer 1 End	7	✓	✓	✓	✓	✓	✓
Timer 2 End	8	✓	✓	✓	✓	✓	✓
L3	9	✓	✓	✓	✓	✓	✓
L4	10	✓	✓	✓	✓	✓	✓
L5	11	✓	✓	✓	✓	✓	✓
L6	12	✓	✓	✓	✓	✓	✓
Frame Valid	13	✓	✓	✓	✓	✓	✓
Acquisition Active	14	-	✓	✓	-	✓	✓
Software	15	-	✓	✓	-	✓	✓
Rotary Enc. Output	16	✓	-	✓	✓	-	✓

Counter Description

The Counter counts the Event Source Edges.

The counter Duration is set and when the counted value reaches the duration, the Output of the counter rises to 1. If the reset input of the counter is not set (Off), the counter resets immediately : The end count value is set in the "Value at Reset", the output is reset and Counter restarts counting on the same event.

The Reset input can be set on an external source and also can maintain the reset of the counter (on level)

As soon as the Reset input is set but not active, the counter counts. If it

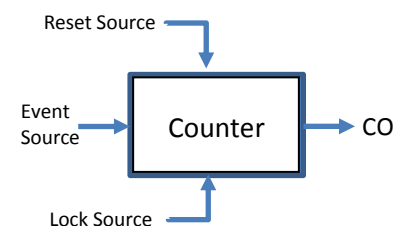

reaches the duration before any reset, the output rises to 1 and the counter carries on counting. Then if the Reset arises, the “Value at Reset” is set with the current value (even higher than the duration), the output is set to 0 and the counter can restart counting on the same even as soon as the reset input switches down to 0.

If the Reset arises before the counter has reached the duration, the “Value at Reset” is set with the current value (even lower than the duration), the output is set to 0 and the counter can restart counting on the same even as soon as the reset input switches down to 0.

The Counter can also be locked by an external source : As soon as the lock input is active, the counter value doesn’t increment on an Event Source edge but can be reset if the reset signal arises.

Timer Description

The Timer starts on its Trigger Source Edge

The Timer Duration is set and when this value is reached, the Timer output rises to 1. If the Reset source is not set (Off) then the Timer resets immediately : The output is reset and Timer restarts after the same event edge.

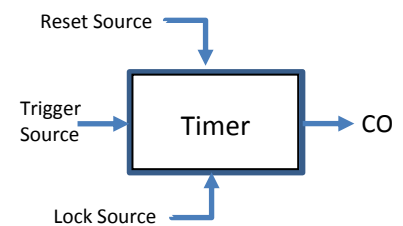

As soon as the Reset input is set but not active, the timer Output remains to 1.

When the Reset arises, the output is set to 0 and the Timer can restart as soon as the reset input switches down to 0. If the reset arises before the end of the Timer duration, the Timer is reset without switching to 1 and can restart as soon as the reset input switches down to 0.

The Timer can also be locked by an external source : As soon as the lock input is active, the Timer stops at its current timing value and can be reset if the reset signal arises. The Timer restarts from its current timing position when the reset input is released.

GenCP address	GenICam Register	Size (Bytes)	R/W	Description
Counter 1				
0x4E05839C	Counter1EventSource	4	RW	Event Source to be counted : 1 : Line Trigger 1 2 : Line Trigger 2 3 : Frame Trigger 4 : FLO (Exposure Active in the Sensor) 6 : Counter 2 End 7 : Timer 1 End 8 : Timer 2 End 9 : L3 10 : L4 11 : L5 12 : L6 13 : Frame Valid 16 : Rotary Encoder Output
0x4E0583A4	Counter1EventActivation	4	RW	Set the Counter 1 Source Activation mode : 0 : Rising Edge 1 : Falling Edge 2 : Any Edge
0x4E0583AC	Counter1ResetSource	4	RW	Set the Source for the Counter 1 Reset : 0 : Off 1 : Line Trigger 1 2 : Line Trigger 2

				3 : Frame Trigger 6 : Counter 2 End 7 : Timer 1 End 8 : Timer 2 End 9 : L3 10 : L4 11 : L5 12 : L6 13 : Frame Valid 14 : Acquisition Active 15 : Software (Use Counter1Software register)
0x4E0583B4	E2v_Counter1ResetActivation	4	RW	Set the Counter 1 Reset Activation mode : 0 : Rising Edge 1 : Falling Edge 2 : Any Edge 3 : Level High 4 : Level Low
0x4E06067C	Counter1LockSource	4	RW	Set the Source for the Counter 1 Lock : 0 : Off 1 : Line Trigger 1 2 : Line Trigger 2 3 : Frame Trigger 4 : FLO (Exposure Active in the Sensor) 6 : Counter 2 End 7 : Timer 1 End 8 : Timer 2 End 9 : L3 10 : L4 11 : L5 12 : L6 13 : Frame Valid 14 : Acquisition Active 15 : Software (Use Counter1LockSoftware register) 16 : Rotary Encoder Output
0x4E060688	Counter1LockActivation	4	RW	Set the Counter 1 Lock Activation mode : 3 : Level High 4 : Level Low
0x4E060690	Counter1LockSoftware	4	RW	Software Register to Lock Counter 1
0x4E0583BC	Counter1Reset	4	RW	Reset command
0x4E0583CC	Counter1ValueAtReset	4	WO	Counter 1 Value at Reset
0x4E0583C4	e2v_Counter1Value	4	RO	Current counter 1 Value
0x4E0583D4	E2v_Counter1Duration	4	RW	Counter 1 duration set by user
0x4E0584A4	Counter1Enable	4	RW	Counter 1 Enable : 0 : Off 1 : On
0x4E0584D0	Counter1Software	4	RW	Software command to Reset Counter1 by Software
Counter 2				
0x4E0583A0	Counter2EventSource	4	RW	Event Source to be counted : 1 : Line Trigger 1 2 : Line Trigger 2 3 : Frame Trigger 4 : FLO (Exposure Active in the Sensor) 5 : Counter 2 End 7 : Timer 1 End 8 : Timer 2 End 9 : L3 10 : L4 11 : L5 12 : L6 13 : Frame Valid 16 : Rotary Encoder Output
0x4E0583A8	Counter2EventActivation	4	RW	Set the Counter 2 Source Activation mode :

				0 : Rising Edge 1 : Falling Edge 2 : Any Edge
0x4E0583B0	Counter2ResetSource	4	RW	Set the Source for the Counter 2 Reset : 0 : Off 1 : Line Trigger 1 2 : Line Trigger 2 3 : Frame Trigger 5 : Counter 2 End 7 : Timer 1 End 8 : Timer 2 End 9 : L3 10 : L4 11 : L5 12: L6 13 : Frame Valid 14 : Acquisition Active 15 : Software (Use Counter2Software register)
0x4E0583B8	Counter2ResetActivation	4	RW	Set the Counter 2 Reset Activation mode : 0 : Rising Edge 1 : Falling Edge 2 : Any Edge 3 : Level High 4 : Level Low
0x4E060680	Counter2LockSource	4	RW	Set the Source for the Counter 2 Lock : 0 : Off 1 : Line Trigger 1 2 : Line Trigger 2 3 : Frame Trigger 4 : FLO (Exposure Active in the Sensor) 6 : Counter 2 End 7 : Timer 1 End 8 : Timer 2 End 9 : L3 10 : L4 11 : L5 12: L6 13 : Frame Valid 14 : Acquisition Active 15 : Software (Use Counter2LockSoftware register) 16 : Rotary Encoder Output
0x4E06068C	Counter2LockActivation	4	RW	Set the Counter 2 Lock Activation mode : 3 : Level High 4 : Level Low
0x4E060694	Counter2LockSoftware	4	RW	Software Register to Lock Counter 2
0x4E0583C0	Counter2Reset	4	RW	Reset command
0x4E0583D0	Counter2ValueAtReset	4	RW	Counter 2 Value at Reset
0x4E0583C8	e2v_Counter2Value	4	RW	Current counter 2 Value
0x4E0583D8	E2v_Counter2Duration	4	RW	Counter 2 duration set by user
0x4E0584A8	Counter2Enable	4	RW	Counter 2 Enable : 0 : Off 1 : On
0x4E0584D4	Counter2Software	4	RW	Software command for a Reset Source set to Software

GenCP address	GenICam Register	Size (Bytes)	R/W	Description
Timer 1				
0x4E0583DC	Timer1TrigSource	4	RW	Event Source to Start the Timer 1 : 1 : Line Trigger 1 2 : Line Trigger 2 3 : Frame Trigger 5 : Counter 1 End 6 : Counter 2 End 8 : Timer 2 End 9 : L3 10 : L4 11 : L5 12 : L6 13 : Frame Valid 16 : Rotary Encoder Output
0x4E0583E4	Timer1Activation	4	RW	Set the Timer 1 Source Activation mode : 0 : Rising Edge 1 : Falling Edge 2 : Any Edge 3 : Level High 4 : Level Low
0x4E0583EC	Timer1Duration	4	RW	Duration of the Timer 1 set by User (in μ s)
0x4E0583FC	Timer1Value	4	RW	Current Timer 1 Value (in μ s)
0x4E058404	Timer1Status	4	RO	Timer 1 Status : 0 : Timer Idle 1 : Wait for Trigger 2 : Timer Active 3 : Timer completed
0x4E0584AC	Timer1Enable	4	RW	Timer 1 Enable : 0 : Off 1 : On
0x4E0584B8	Timer1ResetSource	4	RW	Set the Source for the Timer 1 Reset : 0 : Off 1 : Line Trigger 1 2 : Line Trigger 2 3 : Frame Trigger 5 : Counter 1 End 6 : Counter 2 End 8 : Timer 2 End 9 : L3 10 : L4 11 : L5 12 : L6 13 : Frame Valid 14 : Acquisition Active 15 : Software (Use Timer1Reset register)
0x4E0584C4	Timer1ResetActivation	4	RW	Set the Timer 1 Reset Activation mode : 0 : Rising Edge 1 : Falling Edge 3 : Level High 4 : Level Low
0x4E058514	Timer1Reset	4	RW	Software command for a Reset Source set to Software
0x4E060658	Timer1LockSource	4	RW	Set the Source for the Timer 1 Lock : 0 : Off 1 : Line Trigger 1 2 : Line Trigger 2 3 : Frame Trigger 4 : FLO (Exposure Active in the Sensor) 6 : Counter 2 End 7 : Timer 1 End

				9 : L3 10 : L4 11 : L5 12 : L6 13 : Frame Valid 14 : Acquisition Active 15 : Software (Use Timer1LockSoftware register) 16 : Rotary Encoder Output
0x4E06065C	Timer1LockActivation	4	RW	Set the Timer 1 Lock Activation mode : 3 : Level High 4 : Level Low
0x4E060670	Timer1LockSoftware	4	RW	Software Register to Lock Timer 1
Timer 2				
0x4E0583E0	Timer2TrigSource	4	RW	Event Source to Start the Timer 2 : 1 : Line Trigger 1 2 : Line Trigger 2 3 : Frame Trigger 5 : Counter 1 End 6 : Counter 2 End 7 : Timer 2 End 9 : L3 10 : L4 11 : L5 12 : L6 13 : Frame Valid 16 : Rotary Encoder Output
0x4E0583E8	Timer2Activation	4	RW	Set the Timer 2 Source Activation mode : 0 : Rising Edge 1 : Falling Edge 2 : Any Edge 3 : Level High 4 : Level Low
0x4E0583F0	Timer2Duration	4	RW	Duration of the Timer 2 set by User (in μ s)
0x4E058400	Timer2Value	4	RW	Current Timer 2 Value (in μ s)
0x4E058408	Timer2Status	4	RO	Timer 2 Status : 0 : Timer Idle 1 : Wait for Trigger 2 : Timer Active 3 : Timer completed
0x4E0584B0	Timer2Enable	4	RW	Timer 2 Enable : 0 : Off 1 : On
0x4E0584BC	Timer2ResetSource	4	RW	Set the Source for the Timer 2 Reset : 0 : Off 1 : Line Trigger 1 2 : Line Trigger 2 3 : Frame Trigger 5 : Counter 1 End 6 : Counter 2 End 7 : Timer 2 End 9 : L3 10 : L4 11 : L5 12 : L6 13 : Frame Valid 14 : Acquisition Active 15 : Software (Use Timer2Reset register)
0x4E0584C8	Timer2ResetActivation	4	RW	Set the Timer 2 Reset Activation mode : 0 : Rising Edge 1 : Falling Edge 2 : Any Edge 3 : Level High 4 : Level Low

0x4E058518	Timer2Reset	4	RW	Software command for a Reset Source set to Software
0x4E060660	Timer2LockSource	4	RW	Set the Source for the Timer 2 Lock : 0 : Off 1 : Line Trigger 1 2 : Line Trigger 2 3 : Frame Trigger 4 : FLO (Exposure Active in the Sensor) 6 : Counter 2 End 8 : Timer 2 End 9 : L3 10 : L4 11 : L5 12 : L6 13 : Frame Valid 14 : Acquisition Active 15 : Software (Use Timer2LockSoftware register) 16 : Rotary Encoder Output
0x4E060664	Timer2LockActivation	4	RW	Set the Timer 2 Lock Activation mode : 3 : Level High 4 : Level Low
0x4E060674	Timer2LockSoftware	4	RW	Software Register to Lock Timer 2

7.7 Gain Control

This section includes only the two main gains which have a global action on the whole sensor line :

- The Pre-Amplification Gain (considered as the only Analog Gain as it takes place in the sensor during the ADC conversion) and which is detailed below. The value proposed are : x1, x2, x4, x8
- The Amplification Gain : Adjustment gain or fine digital gain up to 8dB to compensate between each value of the Pre-Amplification Gain. It is implemented as following : $(1 + \text{Gain}/4096)$ with "Gain" between 0 to 6193.

There are 4 of these gains available : One gain per Cycling Preset. This is the only global Gain that can be switched as quickly to be available the next line.

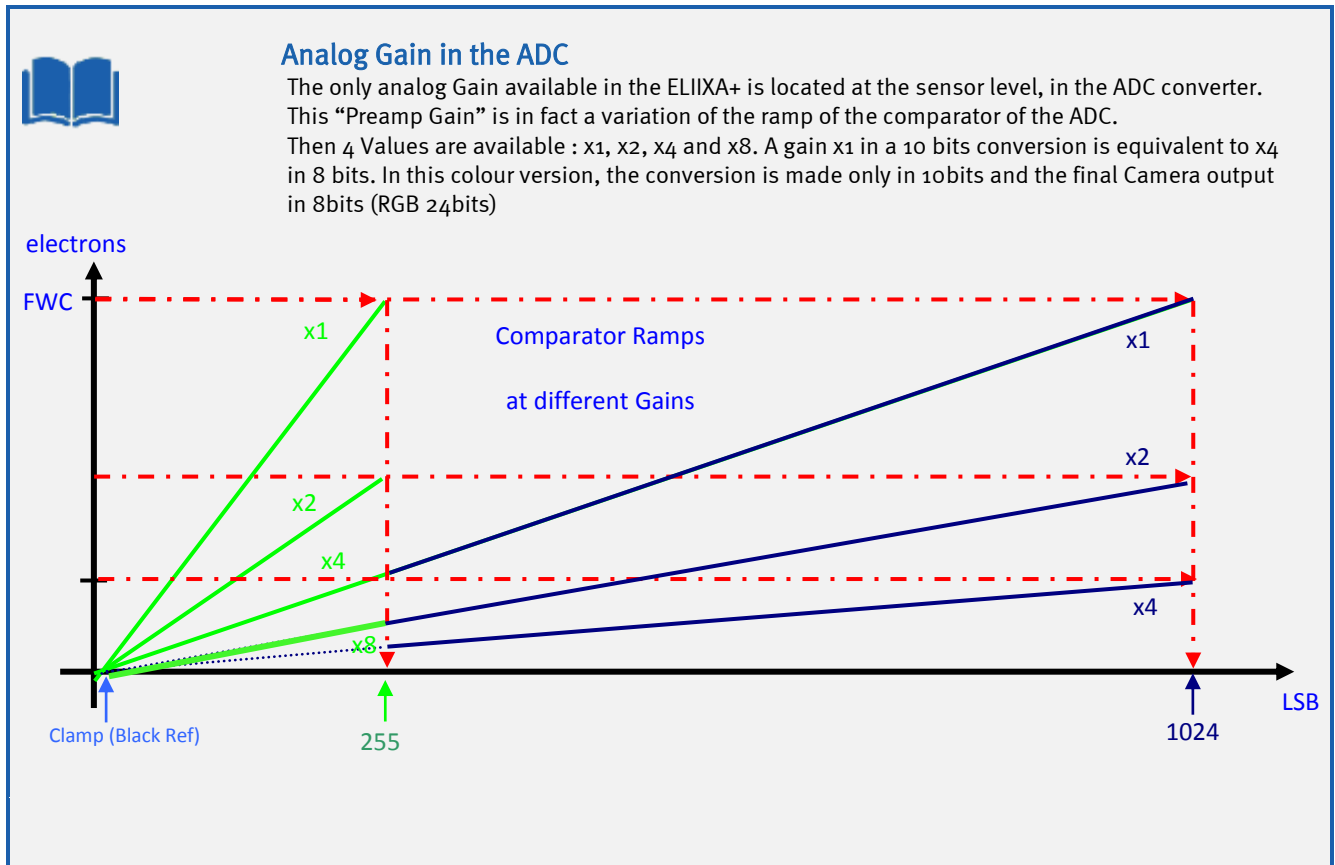
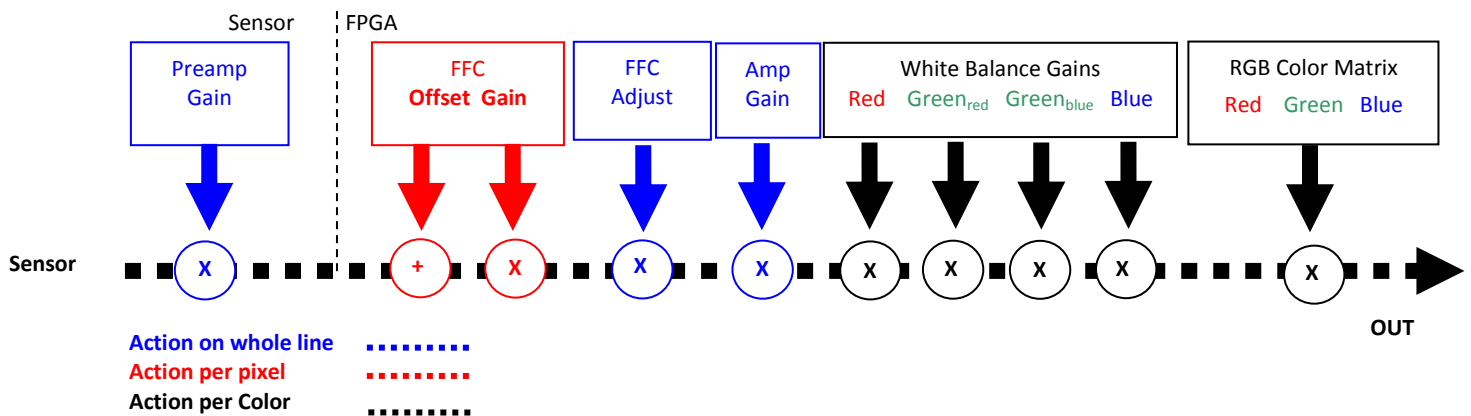

GenCP address	GenICam command	Size	R/W	Description
0x4E05803C	PreampGain	4	RW	Pre-amplifier gain to: 0 : x1 1 : x2 2 : x4 3 : x8 :
0x4E058028	GainAll_PR1	4	RW	Preset 1 (Cycling Mode) and default Digital gain from 0dB (0) to +8dB (6193) : $(1 + \langle \text{Val} \rangle / 4096)$
0x4E05802C	GainAll_PR2	4	RW	Preset 2 (Cycling Mode) Digital gain from 0dB (0) to +8dB (6193) : $(1 + \langle \text{Val} \rangle / 4096)$
0x4E058030	GainAll_PR3	4	RW	Preset 3 (Cycling Mode) Digital gain from 0dB (0) to +8dB (6193) : $(1 + \langle \text{Val} \rangle / 4096)$
0x4E058034	GainAll_PR4	4	RW	Preset 4 (Cycling Mode) Digital gain from 0dB (0) to +8dB (6193) : $(1 + \langle \text{Val} \rangle / 4096)$
0x4E0585CC	StabilizedGain	4	RW	STB Gain when sensor mode is set to 4S Mode with Integration Time Controlled $\langle \text{val} \rangle$: from 0 (x1) to 49152 (x4) $(1 + \text{val} / 16384)$



The Gain x8 has to be used with precaution : An FFC User Calibration could be required when using this level of Gain.

7.8 Flat Field Correction Control

7.8.1 FFC Calibration and Bank/Preset Saving



How is performed the Flat Field Correction ?

What is the Flat Field correction (FFC) ?

The Flat Field Correction is a digital correction on each pixel which allows :

- To correct the Pixel PRNU (Pixel Response Non Uniformity) and DSNU (Dark Signal Non Uniformity)
- To Correct the shading due to the lens
- To correct the Light source non uniformity

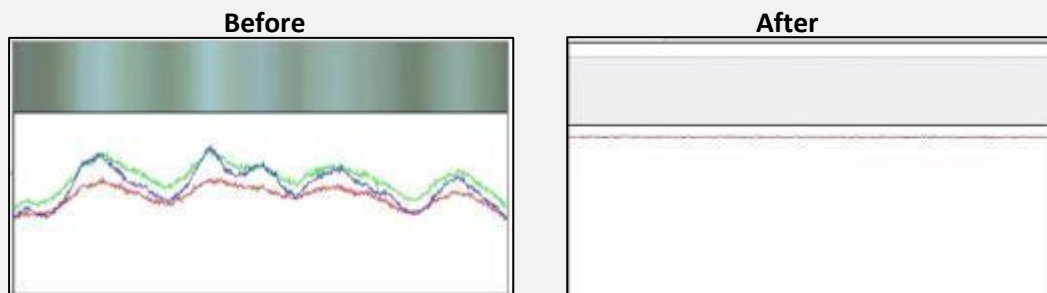

How is calculated / Applied the FFC ?

The FFC is a digital correction on the pixel level for both Gain and Offset.

Each Pixel is corrected with :

- An Offset on 10 bits (Signed Int S9.1). They cover a dynamic of $\pm 256\text{LSB}$ in 12bits with a resolution of $1/2\text{ LSB}$ 12bits. Offset : the MSB is the sign, the rest of 9bits is from 0 .. 256 with precision of $1/2$
- A Gain on 14 bits (Unsigned Int U1.13) with a max gain value of **x4.999**

The calculation of the new pixel value is : $P' = (P + \text{Off}).(1 + \text{Gain}/1024)$. Gain : 0 to 4095

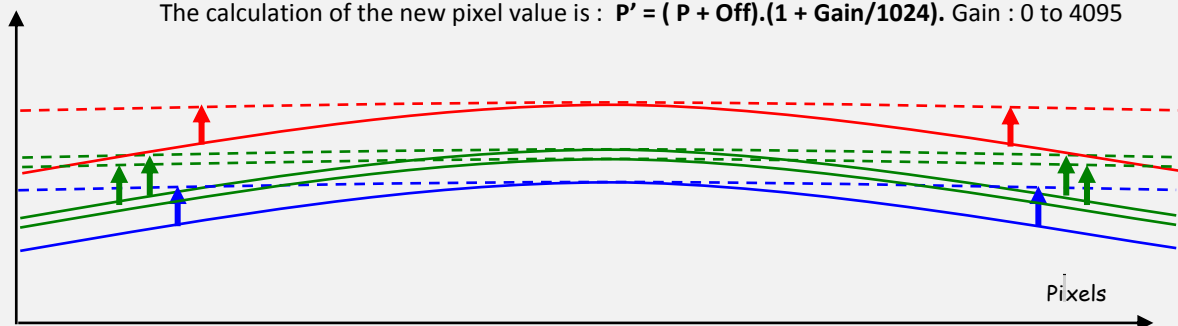

Standard FFC computed on the max of the line for each color (Green_{Blue} and Green_{Red} are treated separately). Then the White Balance will overlay the colors



How to perform the Flat Field Correction ?

Don't forget first to setup the Cycling Preset Selector (Acquisition Control / Cycling Preset) in order to select in which Preset (1, 2, 3, 4 or All) you'll save the result of your FFC once calculated.
If the Cycling Preset Mode is not activated, by default it will be saved in Preset 1.

FPN/DSNU Calibration

- > Cover the lens
- > Launch the FPN Calibration : Grab and calculation is performed in few seconds

PRNU Calibration

The User must propose a white/grey uniform target to the Camera;
The Gain/Light conditions must give a non-saturated image in any Line.
The Camera must be set in the final conditions of Light/ Gain and in the final position in the System.
If required, set a user target for the FFC adjust and enable it.

- > White uniform (moving) target. Use The FFC Low Band Filter if the Target can't move.
This will remove the defects of the target itself
- > Launch the FFC
- > Enable the FFC
- > You can save the FFC result (both FPN+PRNU in the same time) in one of the 4 x FFC User Banks.
- > The user target and Gain are saved with the associated FFC in the same memory.
- > Remove the FFC Low Band filter (set to 0) if used during the Process.

Advices

The ELIXA+ Cameras have 4 x FFC Banks to save 4 x different FFC calibrations. You can use this feature if your system needs some different conditions of lightning and/or Gain because of the inspection of different objects : You can perform one FFC to be associated with one condition of Gain/setting of the Camera (4 Max) and recall one of the four global settings (Camera Configuration + FFC + Line Quarters Balance) when required.

If you intend to use several settings of Light, then several FFC, you need to enable the cycling Preset Mode and save your FFC, no more in the different Banks but in the 4x different Presets available and thus can be done in the same User Bank.



Some Warnings can be issued from the PRNU/FPN Calibration Process as "pixel Overflow" of "Pixel Underflow" because some pixels have been detected as too high or too low in the source image to be corrected efficiently.

The Calculation result will be proposed anyway as it's just a warning message.

The Status Register is the changed and displayed in CommCam "Status" section :
Register status is detailed chap §7.2.

7.8.2 PRNU Low Frequency Filter for FFC

The FFC Low Band Filter allows an easier make in use of the FFC (PRNU Part) : You can use a non-moving paper and you can filter the defects of these paper before the FFC calculation in order to not take them in account. The command “LowFilterWidth” sets the intervals (+/-) around each pixel for the average calculation. Each pixel is then compared to the average on the interval around it and replaced by this average if the difference is too high. With a filter value set at “X”, the calculation interval will be [-X , +X] around the pixel position.

A large interval value allows filtering big defects on the paper but finally the setting of this interval depends also on the magnification in the system.



The FFC Low band filter is just an help to make in use the FFC (PRNU part) more easily : This can be done with a non-moving white paper as its defaults will be filtered in order to not being taken in account in the PRNU Correction.
Don't forget to reset the filter (to “0”) after usage.

GenCP address	GenICam command	Size	R/W	Description
0x4E058448	FFCEnable	4	RW	Enable the FFC : 0 : Disable : 1 : Enable
0x4E058488	FPNReset	4	WO	Reset DSNU coefficients (Offsets) for corresponding cycling Preset (set value to 0 for neutral value) : Bit 0 =1 : Reset DSNU Preset 1 Bit 1 =1 : Reset DSNU Preset 2 Bit 2 =1 : Reset DSNU Preset 3 Bit 3 =1 : Reset DSNU Preset 4
0x4E05848C	PRNUReset	4	WO	Reset PRNU coefficients (Gains) for corresponding cycling Preset (set value to 0 for neutral value) : Bit 0 =1 : Reset PRNU Preset 1 Bit 1 =1 : Reset PRNU Preset 2 Bit 2 =1 : Reset PRNU Preset 3 Bit 3 =1 : Reset PRNU Preset 4
0x4E058444	FPNCalibrationCtrl	4	WO	Start DSNU calibration : Bit 0 : Start DSNU Preset 1 Bit 1 : Start DSNU Preset 2 Bit 2 : Start DSNU Preset 3 Bit 3 : Start DSNU Preset 4
0x4E058440	FPNCalibrationAbort	4	WO	Set to 1 to abort DSNU calibration
0x4E058450	PRNUCalibrationCtrl	4	WO	Start PRNU calibration : Bit 0 : Start PRNU Preset 1 Bit 1 : Start PRNU Preset 2 Bit 2 : Start PRNU Preset 3 Bit 3 : Start PRNU Preset 4
0x4E058454	PRNUCalibrationAbort	4	WO	Set to 1 to abort PRNU calibration
0x4E05844C	LowFilterWidth	4	RW	Width of the low filter for PRNU calculation : 0 is for a disabled filter. 1 to 63 for a Filter Interval of [-<val> , +<Val>]

GenCP address	GenICam command	Size	R/W	Description
FFC Memory Zone Manual Management				
0x10000	FPNCoefficientsAccess (1)	4096 x 2	RW	Access to DSNU coeff for Preset 1 (2 Bytes each) Format S9.1: -256 (512) to -1 (1023), 0 (0) to 255.5 (511) step 0.5.
0x20000	FPNCoefficientsAccess (2)	4096 x 2	RW	Access to DSNU coeff for Preset 2 (2 Bytes each) Format S9.1: -256 (512) to -1 (1023), 0 (0) to 255.5 (511) step 0.5
0x30000	FPNCoefficientsAccess (3)	4096 x 2	RW	Access to DSNU coeff for Preset 3 (2 Bytes each) Format S9.1: -256 (512) to -1 (1023), 0 (0) to 255.5 (511) step 0.5
0x40000	FPNCoefficientsAccess (4)	4096 x 2	RW	Access to DSNU coeff for Preset 4 (2 Bytes each) Format S9.1: -256 (512) to -1 (1023), 0 (0) to 255.5 (511) step 0.5
0x50000	PRNUCoefficientsAccess(1)	4096 x 2	RW	Access to PRNU coeff for Preset 1 (2 Bytes each) Format U1.13: 1 (0) to x4.999023 (4095) = 1 + <val>/1024
0x60000	PRNUCoefficientsAccess(2)	4096 x 2	RW	Access to PRNU coeff for Preset 2 (2 Bytes each) Format U1.13: 1 (0) to x4.999023 (4095) = 1 + <val>/1024
0x70000	PRNUCoefficientsAccess(3)	4096 x 2	RW	Access to PRNU coeff for Preset 3 (2 Bytes each) Format U1.13: 1 (0) to x4.999023 (4095) = 1 + <val>/1024
0x80000	PRNUCoefficientsAccess(4)	4096 x 2	RW	Access to PRNU coeff for Preset 4 (2 Bytes each) Format U1.13: 1 (0) to x4.999023 (4095) = 1 + <val>/1024

7.9 Color Management Control

This section deals with the Colour settings (White Balance and Colour Matrix and Colour Interpolation corrections for the True Colour Modes)

For each of the 4x Presets there are :

- One set of White Balance Gains : Red, Green(Red), Green(Blue), Blue
- One Colour Correction Matrix.

7.9.1 White Balance

The White balance can be calculated on a specific User-defined Region of Interest (Start/Width) : This allows the User to select an area where the target is always uniform grey.

The Automatic White Balance calculates the average value for each colour on the dedicated Region of Interest. Then, a Gain is calculated for each colour to reach the highest value (which Gain will be x1).

The Automatic white balance can be computed permanently by setting and enabling the WhiteBalanceAdjustTarget : a permanent calculation will be done on the WhiteBalanceROI

At this level, there is a differentiation for the Green Pixels facing a Blue or a Red Pixel : They are assigned with a different Gain Value.

7.9.2 RGB Color Matrix

This RGB Color Matrix allows a fine adjustment of the RGB colors to the Light source used.

$$\begin{pmatrix} R' & G' & B' \end{pmatrix} = \begin{pmatrix} C_{RR} & C_{RG} & C_{RB} \\ C_{GR} & C_{GG} & C_{GB} \\ C_{BR} & C_{BG} & C_{BB} \end{pmatrix} \times \begin{pmatrix} R \\ G \\ B \end{pmatrix}$$

Each (RGB) Color Triplet becomes a Linear combination of each color :

$$R' = C_{RR} \cdot R + C_{RG} \cdot G + C_{RB} \cdot B$$

$$G' = C_{GR} \cdot R + C_{GG} \cdot G + C_{GB} \cdot B$$

$$B' = C_{BR} \cdot R + C_{BG} \cdot G + C_{BB} \cdot B$$

An Example of fine adjustment with white LEDs :

Before



After



GenCP address	GenICam Command	Size	R/W	Description
0x4E058044	WhiteBalanceEnable	4	RW	Enable the White Balance : 0 : Disable 1 : Enable
0x4E05804C	WhiteBalanceAbort	4	WO	Abort the White Balance Process 1 : Abort
0x4E058048	WhiteBalanceCalibration	4	RW	Start the White Balance Process (Write command) : 1 : Start Readout White Balance Status (Read Command) : 0 : Terminated 1 : Active
0x4E058060	ColumnInterpolationEnable	4	RW	Enable the Colum Interpolation Correction : 0 : Disable 1 : Enable
0x4E058064	LineInterpolationEnable	4	RW	Enable the Line Interpolation Correction : 0 : Disable 1 : Enable
0x4E0605F8	WhiteBalanceAdjustEnable	4	RW	Enable the Automatic and permanent WB on the ROI: 0 : Disable 1 : Enable
0x4E0605F4	WhiteBalanceAdjustTarget	4	RW	<val> : Target to be reach during a white balance calibration from 0 to 255 (default 200)
0x4E058434	WhiteBalanceROIStart	4	RW	Start of the ROI for White Balance Calculation : Value from 0 to SensorWidth - 4
0x4E058438	WhiteBalanceROIWidth	4	RW	Width of the ROI for White Balance Calculation : Value from 4 to SensorWidth – WhiteBalanceROIStart Must be multiple of 4
0x4E058048	PresetWhiteBalanceSelector	4	RW	Selects the Cycling Preset to save the automatic White Balance Calibration : 1: Preset 1 2 : Preset 2 4: Preset 3 8 : Preset 4 15: All Presets
Preset 1				
White Balance				
0x4E0580C8	DigitalRed_PR1	4	RW	Gain Red for White Balance Preset 1 <val> from 0 to 1548 (8dB) Gain = 1 + <val>/1024
0x4E0580CC	DigitalBlue_PR1	4	RW	Gain Blue for White Balance Preset 1 <val> from 0 to 1548 (8dB) Gain = 1 + <val>/1024
0x4E058050	DigitalGreenR_PR1	4	RW	Gain Green(Red) for White Balance Preset 1 <val> from 0 to 1548 (8dB) Gain = 1 + <val>/1024
0x4E0580C4	DigitalGreenB_PR1	4	RW	Gain Green(Blue) for White Balance Preset 1 <val> from 0 to 1548 (8dB) Gain = 1 + <val>/1024
Color Matrix				
0x4E05812C	ColorMatrixGainRed_Red_PR1	4	RW	Gain Red(Red) for color matrix Preset 1 <val> S3.6 from x(-4) (-256) to x3.98 (255) Gain = <val>/64
0x4E05813C	ColorMatrixGainRed_Green_PR1	4	RW	Gain Red(Green) for color matrix Preset 1 <val> S3.6 from x(-4) (-256) to x3.98 (255) Gain = <val>/64
0x4E05814C	ColorMatrixGainRed_Blue_PR1	4	RW	Gain Red(Blue) for color matrix Preset 1 <val> S3.6 from x(-4) (-256) to x3.98 (255) Gain = <val>/64

GenCP address	GenICam Command	Size	R/W	Description
0x4E05815C	ColorMatrixGainGreen_Red_PR1	4	RW	Gain Green(Red) for color matrix Preset 1 <val> S3.6 from x(-4) (-256) to x3.98 (255) Gain = <val>/64
0x4E05816C	ColorMatrixGainGreen_Green_PR1	4	RW	Gain Green(Green) for color matrix Preset 1 <val> S3.6 from x(-4) (-256) to x3.98 (255) Gain = <val>/64
0x4E05817C	ColorMatrixGainGreen_Blue_PR1	4	RW	Gain Green(Blue) for color matrix Preset 1 <val> S3.6 from x(-4) (-256) to x3.98 (255) Gain = <val>/64
0x4E05818C	ColorMatrixGainBlue_Red_PR1	4	RW	Gain Blue(Red) for color matrix Preset 1 <val> S3.6 from x(-4) (-256) to x3.98 (255) Gain = <val>/64
0x4E05819C	ColorMatrixGainBlue_Green_PR1	4	RW	Gain Blue(Green) for color matrix Preset 1 <val> S3.6 from x(-4) (-256) to x3.98 (255) Gain = <val>/64
0x4E0581AC	ColorMatrixGainBlue_Blue_PR1	4	RW	Gain Blue(Blue) for color matrix Preset 1 <val> S3.6 from x(-4) (-256) to x3.98 (255) Gain = <val>/64
Preset 2				
White Balance				
0x4E0580F4	DigitalGreenB_PR2	4	RW	Gain Red for White Balance Preset 2 <val> from 0 to 1548 (8dB) Gain = 1 + <val>/1024
0x4E0580E8	DigitalGreenR_PR2	4	RW	Gain Blue for White Balance Preset 2 <val> from 0 to 1548 (8dB) Gain = 1 + <val>/1024
0x4E0580DC	DigitalBlue_PR2	4	RW	Gain Green(Red) for White Balance Preset 2 <val> from 0 to 1548 (8dB) Gain = 1 + <val>/1024
0x4E0580D0	DigitalRed_PR2	4	RW	Gain Green(Blue) for White Balance Preset 2 <val> from 0 to 1548 (8dB) Gain = 1 + <val>/1024
Color Matrix				
0x4E0581B0	ColorMatrixGainBlue_Blue_PR2	4	RW	Gain Red(Red) for color matrix Preset 2 <val> S3.6 from x(-4) (-256) to x3.98 (255) Gain = <val>/64
0x4E0581A0	ColorMatrixGainBlue_Green_PR2	4	RW	Gain Red(Green) for color matrix Preset 2 <val> S3.6 from x(-4) (-256) to x3.98 (255) Gain = <val>/64
0x4E058190	ColorMatrixGainBlue_Red_PR2	4	RW	Gain Red(Blue) for color matrix Preset 2 <val> S3.6 from x(-4) (-256) to x3.98 (255) Gain = <val>/64
0x4E058180	ColorMatrixGainGreen_Blue_PR2	4	RW	Gain Green(Red) for color matrix Preset 2 <val> S3.6 from x(-4) (-256) to x3.98 (255) Gain = <val>/64
0x4E058170	ColorMatrixGainGreen_Green_PR2	4	RW	Gain Green(Green) for color matrix Preset 2 <val> S3.6 from x(-4) (-256) to x3.98 (255) Gain = <val>/64
0x4E058160	ColorMatrixGainGreen_Red_PR2	4	RW	Gain Green(Blue) for color matrix Preset 2 <val> S3.6 from x(-4) (-256) to x3.98 (255) Gain = <val>/64
0x4E058150	ColorMatrixGainRed_Blue_PR2	4	RW	Gain Blue(Red) for color matrix Preset 2 <val> S3.6 from x(-4) (-256) to x3.98 (255) Gain = <val>/64
0x4E058140	ColorMatrixGainRed_Green_PR2	4	RW	Gain Blue(Green) for color matrix Preset 2 <val> S3.6 from x(-4) (-256) to x3.98 (255) Gain = <val>/64
0x4E058134	ColorMatrixGainRed_Red_PR2	4	RW	Gain Blue(Blue) for color matrix Preset 2 <val> S3.6 from x(-4) (-256) to x3.98 (255)

GenCP address	GenICam Command	Size	R/W	Description
				Gain = <val>/64
Preset 3				
White Balance				
0x4E0580F8	DigitalGreenB_PR3	4	RW	Gain Red for White Balance Preset 3 <val> from 0 to 1548 (8dB) Gain = 1 + <val>/1024
0x4E0580EC	DigitalGreenR_PR3	4	RW	Gain Blue for White Balance Preset 3 <val> from 0 to 1548 (8dB) Gain = 1 + <val>/1024
0x4E0580E0	DigitalBlue_PR3	4	RW	Gain Green(Red) for White Balance Preset 3 <val> from 0 to 1548 (8dB) Gain = 1 + <val>/1024
0x4E0580D4	DigitalRed_PR3	4	RW	Gain Green(Blue) for White Balance Preset 3 <val> from 0 to 1548 (8dB) Gain = 1 + <val>/1024
Color Matrix				
0x4E0581B4	ColorMatrixGainBlue_Blue_PR3	4	RW	Gain Red(Red) for color matrix Preset 3 <val> S3.6 from x(-4) (-256) to x3.98 (255) Gain = <val>/64
0x4E0581A4	ColorMatrixGainBlue_Green_PR3	4	RW	Gain Red(Green) for color matrix Preset 3 <val> S3.6 from x(-4) (-256) to x3.98 (255) Gain = <val>/64
0x4E058194	ColorMatrixGainBlue_Red_PR3	4	RW	Gain Red(Blue) for color matrix Preset 3 <val> S3.6 from x(-4) (-256) to x3.98 (255) Gain = <val>/64
0x4E058184	ColorMatrixGainGreen_Blue_PR3	4	RW	Gain Green(Red) for color matrix Preset 3 <val> S3.6 from x(-4) (-256) to x3.98 (255) Gain = <val>/64
0x4E058174	ColorMatrixGainGreen_Green_PR3	4	RW	Gain Green(Green) for color matrix Preset 3 <val> S3.6 from x(-4) (-256) to x3.98 (255) Gain = <val>/64
0x4E058164	ColorMatrixGainGreen_Red_PR3	4	RW	Gain Green(Blue) for color matrix Preset 3 <val> S3.6 from x(-4) (-256) to x3.98 (255) Gain = <val>/64
0x4E058154	ColorMatrixGainRed_Blue_PR3	4	RW	Gain Blue(Red) for color matrix Preset 3 <val> S3.6 from x(-4) (-256) to x3.98 (255) Gain = <val>/64
0x4E058144	ColorMatrixGainRed_Green_PR3	4	RW	Gain Blue(Green) for color matrix Preset 3 <val> S3.6 from x(-4) (-256) to x3.98 (255) Gain = <val>/64
0x4E058130	ColorMatrixGainRed_Red_PR3	4	RW	Gain Blue(Blue) for color matrix Preset 3 <val> S3.6 from x(-4) (-256) to x3.98 (255) Gain = <val>/64
Preset 4				
White Balance				
0x4E0580FC	DigitalGreenB_PR4	4	RW	Gain Red for White Balance Preset 4 <val> from 0 to 1548 (8dB) Gain = 1 + <val>/1024
0x4E0580F0	DigitalGreenR_PR4	4	RW	Gain Blue for White Balance Preset 4 <val> from 0 to 1548 (8dB) Gain = 1 + <val>/1024
0x4E0580E4	DigitalBlue_PR4	4	RW	Gain Green(Red) for White Balance Preset 4 <val> from 0 to 1548 (8dB) Gain = 1 + <val>/1024
0x4E0580D8	DigitalRed_PR4	4	RW	Gain Green(Blue) for White Balance Preset 4 <val> from 0 to 1548 (8dB) Gain = 1 + <val>/1024

GenCP address	GenICam Command	Size	R/W	Description
Color Matrix				
0x4E0581B8	ColorMatrixGainBlue_Blue_PR4	4	RW	Gain Red(Red) for color matrix Preset 4 <val> S3.6 from x(-4) (-256) to x3.98 (255) Gain = <val>/64
0x4E0581A8	ColorMatrixGainBlue_Green_PR4	4	RW	Gain Red(Green) for color matrix Preset 4 <val> S3.6 from x(-4) (-256) to x3.98 (255) Gain = <val>/64
0x4E058198	ColorMatrixGainBlue_Red_PR4	4	RW	Gain Red(Blue) for color matrix Preset 4 <val> S3.6 from x(-4) (-256) to x3.98 (255) Gain = <val>/64
0x4E058188	ColorMatrixGainGreen_Blue_PR4	4	RW	Gain Green(Red) for color matrix Preset 4 <val> S3.6 from x(-4) (-256) to x3.98 (255) Gain = <val>/64
0x4E058178	ColorMatrixGainGreen_Green_PR4	4	RW	Gain Green(Green) for color matrix Preset 4 <val> S3.6 from x(-4) (-256) to x3.98 (255) Gain = <val>/64
0x4E058168	ColorMatrixGainGreen_Red_PR4	4	RW	Gain Green(Blue) for color matrix Preset 4 <val> S3.6 from x(-4) (-256) to x3.98 (255) Gain = <val>/64
0x4E058158	ColorMatrixGainRed_Blue_PR4	4	RW	Gain Blue(Red) for color matrix Preset 4 <val> S3.6 from x(-4) (-256) to x3.98 (255) Gain = <val>/64
0x4E058148	ColorMatrixGainRed_Green_PR4	4	RW	Gain Blue(Green) for color matrix Preset 4 <val> S3.6 from x(-4) (-256) to x3.98 (255) Gain = <val>/64
0x4E058138	ColorMatrixGainRed_Red_PR4	4	RW	Gain Blue(Blue) for color matrix Preset 4 <val> S3.6 from x(-4) (-256) to x3.98 (255) Gain = <val>/64

7.10 Device Access Control

Set the Privilege access of the Camera (only Integrator ↔ User)

GenCP address	GeniCam Command	Size	R/W	Description
0x4E0580BC	CameraPrivilegeLevel	4	RO	Display the current Privilege Level : 0 : Factory Mode 1 : Integrator Mode 2 : User Mode
0x4E0580C0	ChangePrivilegeLevel	4	RW	Set the Privilege Level : 1 : Set back Factory => Integrator 2 : Set back Integrator => User Setting back User => Integrator requires a code (ask to support)

7.11 Save and Restore

The Camera Parameters are divided in 3 different categories to be saved in Memory :

- **Flat Field Correction** : All the results of FFC Calibration (DSNU + PRNU). FFC Enable or FFC Filter width are saved in Camera Configuration bank (below)
- **Colour** : White balance Gains, Interpolation Corrections, Colour Correction Matrix and WB ROI. The Enable Switches (WB and CCM) are saved in Camera Configuration bank (below)
- **Camera Configuration** : All the other parameters including Image Format, Acquisition, GPIO, ... and enable switches for FFC, White Balance and Colour Correction Matrix.

There are 4 User Banks for each category (5 for Camera Configuration with the Integrator Bank) and One Factory (Default) Bank (Bank 0)

Each Bank of each category includes the differentiated parameters of the 4 x Presets for the Cycling Mode : Saving in one User bank implies to save Common parameters as well as all the 4 Presets in the same time.

Then for the differentiated parameters, there are 16 different possibilities (4 (User Bank) x 4 (Preset) :

- Exposure Time
- Exposure Delay
- Amplification Gain
- FFC (DSNU & PRNU)
- White balance Gains (Red, Green(Red), Green(Blue) and Blue
- Colour Correction Matrix

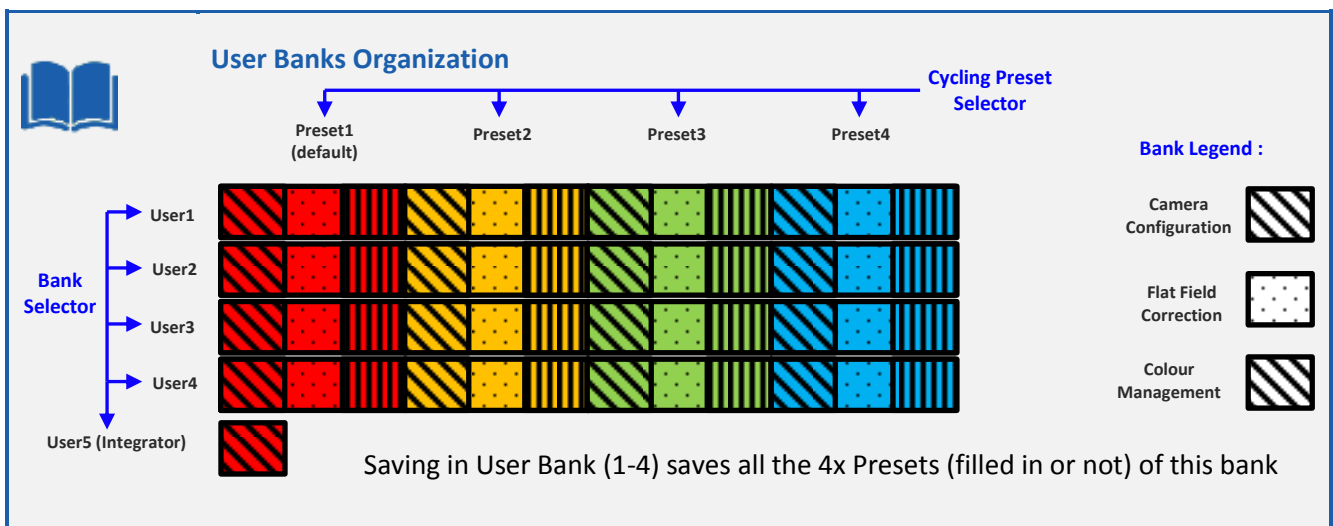

GenCP address	GenCam Command	Size	R/W	Description
Flat Field Correction				
0x4E058480	UserFFCBankRestore	4	RW	Restore FFC User Bank : 0 : Default (Factory) 1 – 4 : User Banks
0x4E05847C	UserFFCBankSave	4	RW	Save FFC User Bank : 1 – 4 : User Banks
0x4E058484	CurrentFFCBank	4	RO	Get the Current FFC Bank in Use : 0 : Default (Factory) 1 – 4 : User Banks
Colour Settings				
0x4E05842C	ColorBankRestore	4	RW	Restore Colour User Bank : 0 : Default (Factory) 1 – 4 : User Banks
0x4E058428	ColorBankSave	4	RW	Save Colour User Bank : 1 – 4 : User Banks
0x4E058430	CurrentColorBank	4	RO	Get the Current Colour Bank in Use : 0 : Default (Factory) 1 – 4 : User Banks
Camera Configuration				
0x4E05841C	UserBankRestore	4	RW	Restore Configuration User Bank : 0 : Default (Factory) 1 – 4 : User Banks 5 : Integrator
0x4E058418	UserBankSave	4	RW	Save Configuration User Bank : 1 – 4 : User Banks 5 : Integrator (Only if Privilege Mode is Integrator = 1)
0x4E058420	CurrentUserBank	4	RO	Get the Current Configuration Bank in Use : 0 : Default (Factory) 1 – 4 : User Banks 5 : Integrator

APPENDIX

Appendix A. Pattern Tests

A.1 Test Pattern 1: Vertical wave

The Test pattern 1 is a vertical moving wave : each new line will increment of 1 grey level in regards with the previous one : level reaches 255 before switching down to 0

A.2 Test Pattern 2: Fixed Horizontal Ramps

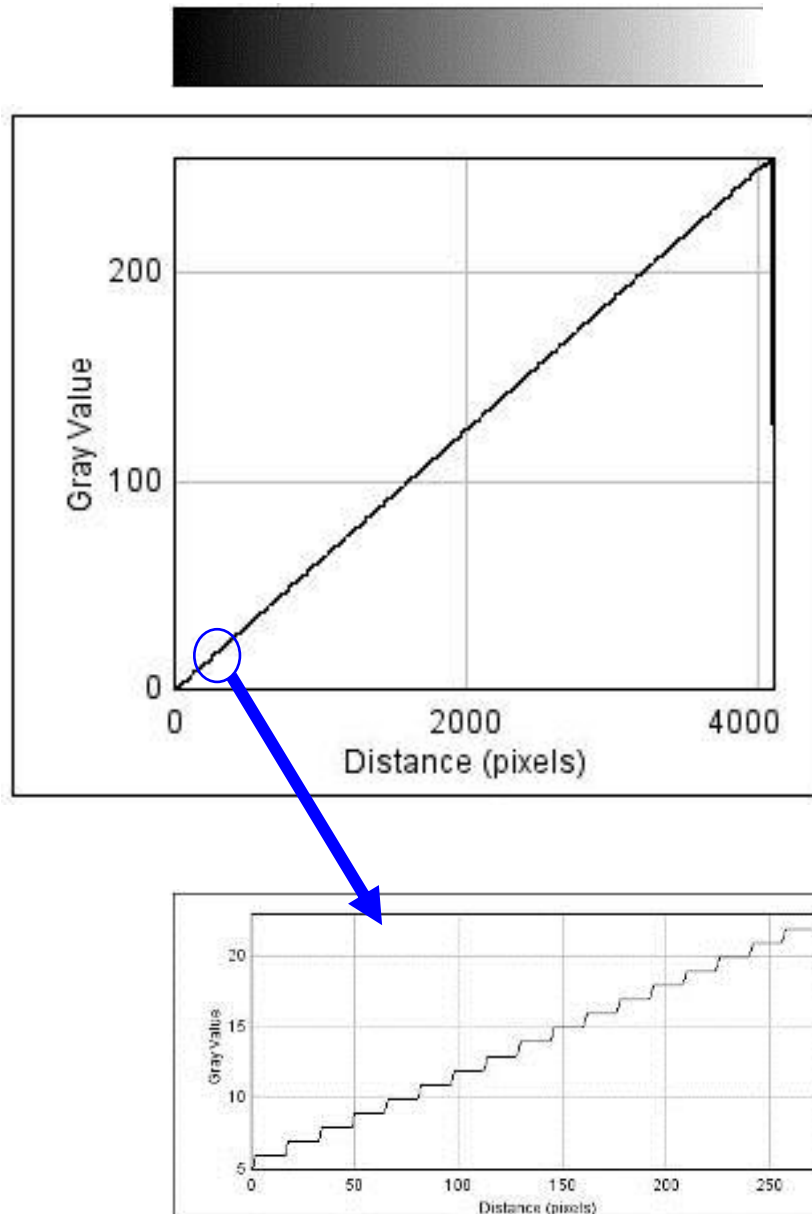

Starting at 0, an increment of 1 LSB is made every 16 pixels. When it reaches 255, turns back to 0 and starts again.

Appendix B. Timing Diagrams

B.1 Synchronization modes with variable Exposure Time

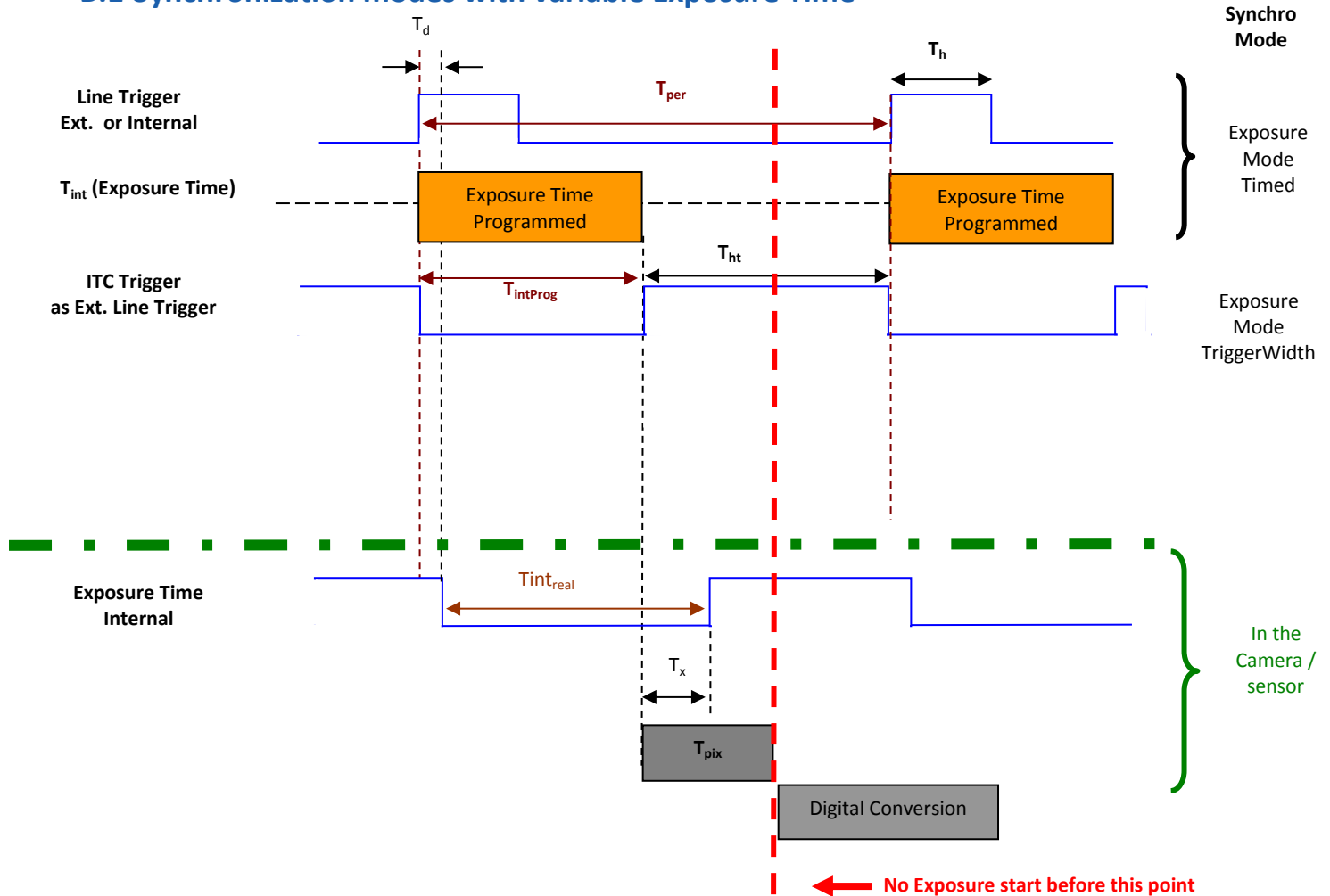

T_{pix} : Timing Pixel. During this uncompressible period, the pixel and its black reference are read out to the Digital converter. During the first half of this timing pixel (read out of the black reference), we can consider that the exposure is still active.

Digital Conversion : During the conversion, the analog Gain is applied by the gradient of the counting ramp (see next chapter : Gain & Offset). The conversion time depends is **6 μ s** (in 8bits per color/Pixel)

This conversion is done in masked time, eventually during the next exposure period.

T_d : Delay between the Start exposure required and the real start of the exposure.



If T_{per} is the Line Period (internal or external coming from the Trigger line), in order to respect this line Period, the Exposure Time as to be set by respecting : $T_{int} + T_{pix} \leq T_{per}$
 Then, the real exposure time is : $T_{int_{real}} = T_{int} + T_x - T_d$
 In the same way, The high level period of the Trig signal in sync=3 mode, $T_{ht} \geq T_{pix}$
 For a Line Period of $LinePer$, the maximum exposure time possible without reduction of line rate is : $T_{int_{max}} = T_{per} - T_{pix}$ (T_{pix} is defined above) but the effective Exposure Time will be about $T_{int_{real}} = T_{int} + T_x - T_d$

B.2 Synchronization modes with Fixed Exposure Time

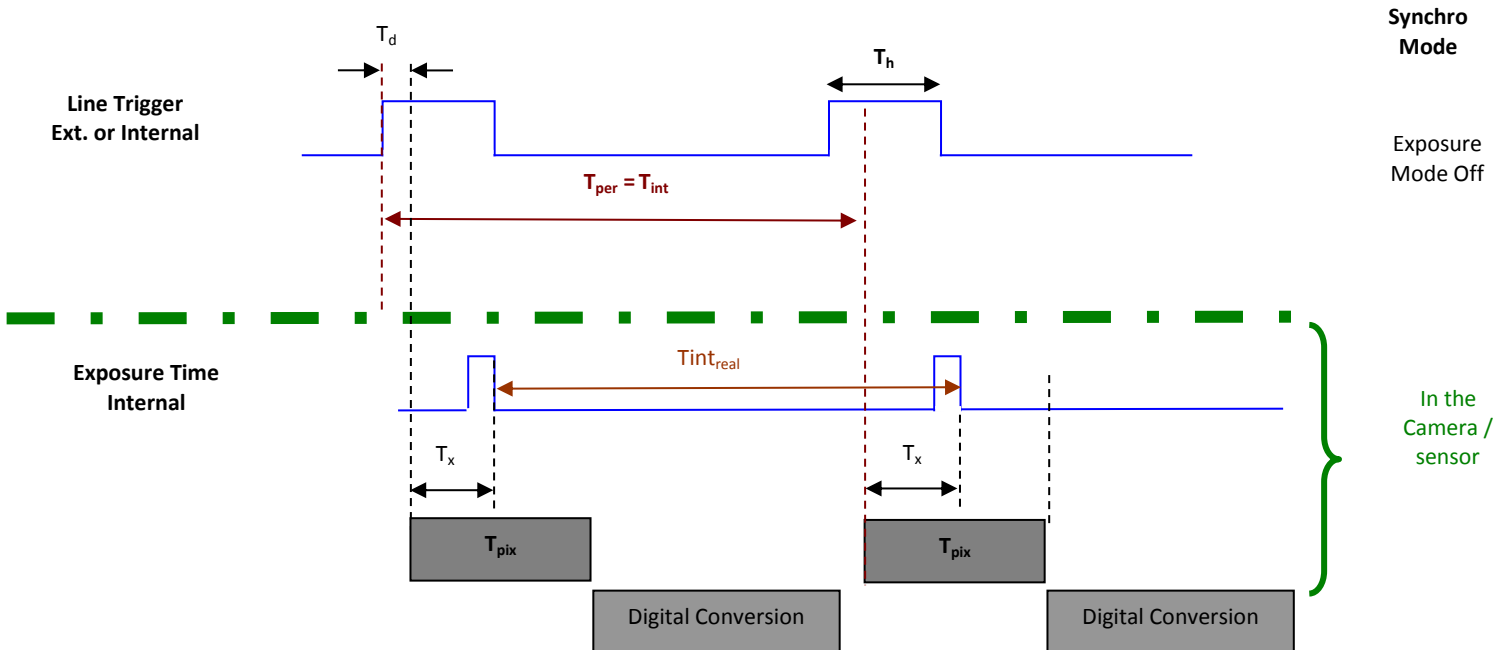

In these modes, the rising edge of the Trigger (internal or External) starts the readout process (T_{pix}) of the previous integration. The Real exposure time ($T_{int_{real}}$) is finally equal to the Line Period (T_{per}) even if it's delayed from ($T_x + T_d$) from the rising edge of the incoming Line Trigger.

B.3 Timing Values

Label	Min	Unit
T_{pix}	2.7	μs
T_x	1.62	μs
T_h	0,120	μs
T_{ht}	T_{pix}	μsec
T_d	0.7	μs

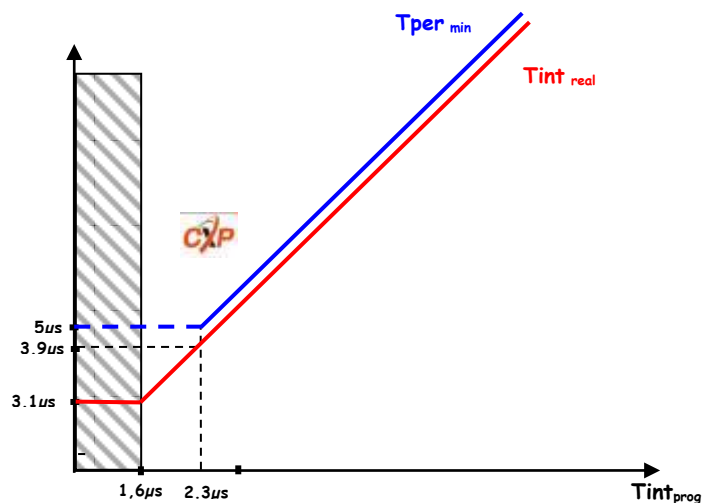

Appendix C. Accessories

C.1 F-Mount



F Mount: (Part number EV50-MOUNT-F)

Drawing for the additional part (except Nikon BR3) :

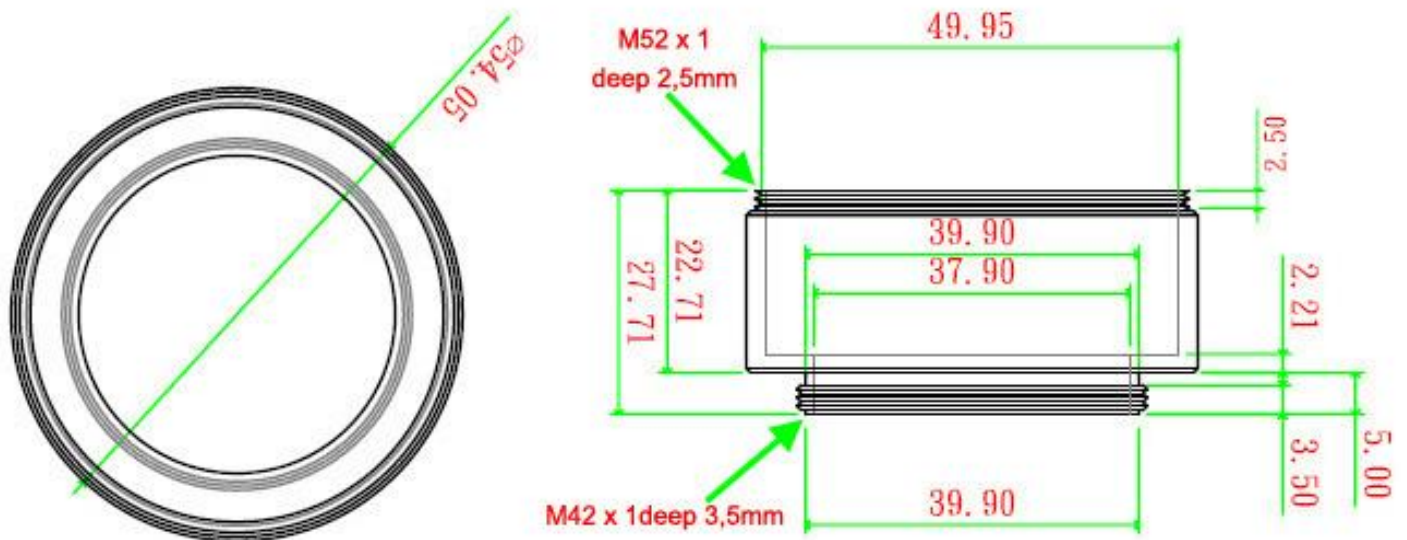

C.2 C-Mount



C Mount : (Part number EV71-C-MOUNT)

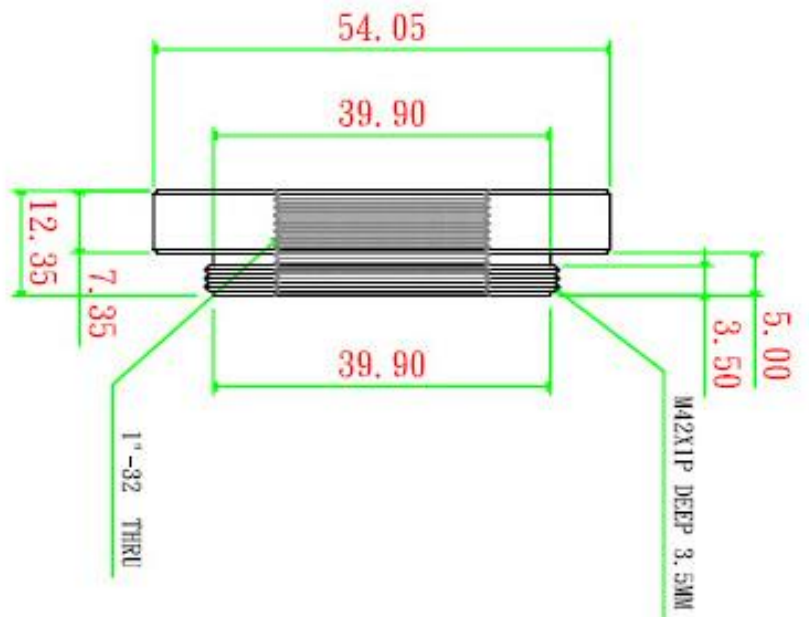
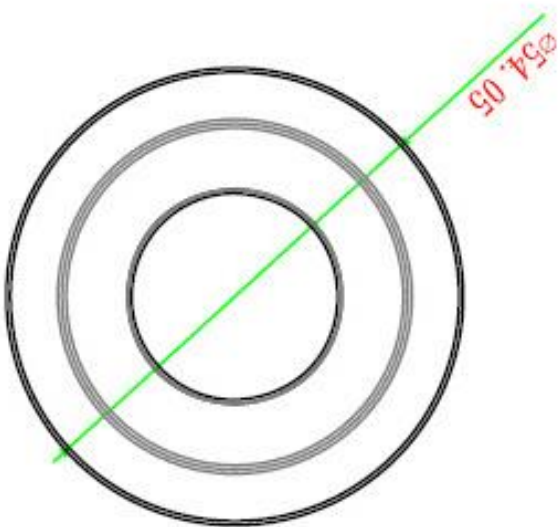

C.3 Set of Heatsinks

The ELIIXA+ NBASE-T Cameras are already delivered with 2 Heat Sinks, but if necessary, additional heat sinks are available (set of 2) and they can be fixed on any side of the front face :

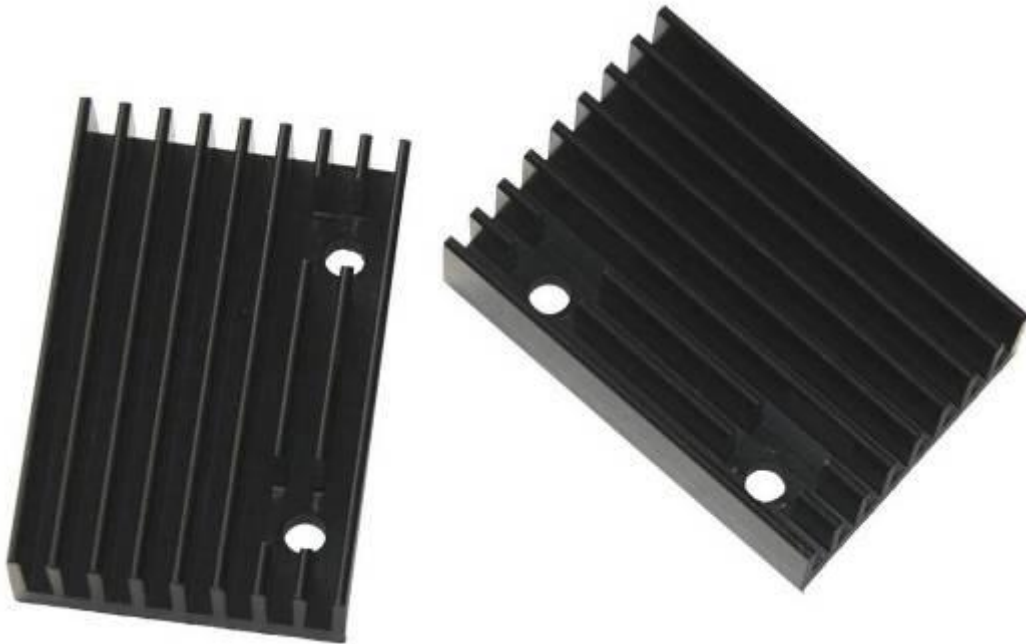

Set of 2 x Heat Sinks : Part number AT71KFPVIVA-CAA

The Camera has been designed to dissipates the maximum of the internal heat through its front face : The packaging of the sensor is larger to increase the surface in contact with the front face and then improves the dissipation. The first part (black) of the rear housing is also important for the Heat dissipation as it's in contact with the FPGA and is used to dissipate its temperature.

In the system, the camera has to be fixed by its front face with the largest contact possible with a metallic part. Without any specific cooling system, a simple air flow around the camera will improve roughly the dissipation.

Appendix D. Network Connection

2x Kits including NBase-T Board and cables (power + Trigger) are available :

D.1 Single Network Board + Cables (GPIO + Power) Kit

This kit includes :

- One Single NBase-T (5/10GigE) board (N480)
- One set of 2 cables (GPIO + Power supply).

Part number : **EVOA0000-ONTCKA0-U**

Contact the Customer Service for more information



D.2 Dual Network Board + Cables (GPIO + Power) Kit

This kit includes :

- One Dual NBase-T (5/10GigE) board (N440)
- 2 sets of 2 cables (GPIO + Power supply).

Part number : **EVOA0000-ONTCKA1-U**

Contact the Customer Service for more information



D.3 Ethernet Cable

The Ethernet cable required is Cat5E at the minimum up to 50m. Cat 6 or even 6A is required for a connection up to 100m.

	2.5G Base-T	5G Base-T
Installed Cat 5e	✓	Extend. Freq.
Installed Cat 6	✓	✓
Installed Cat 6A	✓	✓

0 to 50m cable	Cat 5e	Cat 6	Cat 6A
2.5G Nbase-T			Assured
5G Base-T Assured			Assured

50 to 75m cable	Cat 5e	Cat 6	Cat 6A
2.5G Nbase-T			Assured
5G Base-T Assured			Assured

75 to 100m cable	Cat 5e	Cat 6	Cat 6A
2.5G Nbase-T			Assured
5G Base-T Assured			Assured

ASLNR Risk	High	Medium	Low

D.4 PureGev Application and eBus Package

The ELIIXA+ NBase-T Camera is licensed for the PLEORA eBus Application/Driver and SDK Package : You can download it from the Pleora Website : www.pleora.com

D.5 Driver Configuration and Inter-Operability

The Pleora Driver is recommended for highest performances.

The Camera can also be connected to the following Software (tested) solutions :

- DALSA-Teledyne SAPERA
- Matrox MIL
- National Instruments IMAQ

Appendix E. Revision History

Manual Revision	Comments / Details	Firmware version	PureGev and eBus Package
Rev A	Preliminary release	1.0.0	3.1.7
Rev B	New GPIO Parameters	1.1.1	4.x and 5.x
Rev C	Bug Fix For PacketSize Nogociation with Matrox MIL Trigger Presets Removed Mechanical Positioning Tolerances	1.1.3	"
Rev D	Timing Pixel for iCMos2 Updated Min/Max Input Thresholds Electro Optical values checked with Production Board Kits description in Appendix Change of RX Descriptor recommended value to 1000	1.1.8	"
Rev E	"PreampGain" instead of "PreAmpGain" WhitebalanceAdjust Target and enable	1.1.8	-