

# VX series

## User Manual

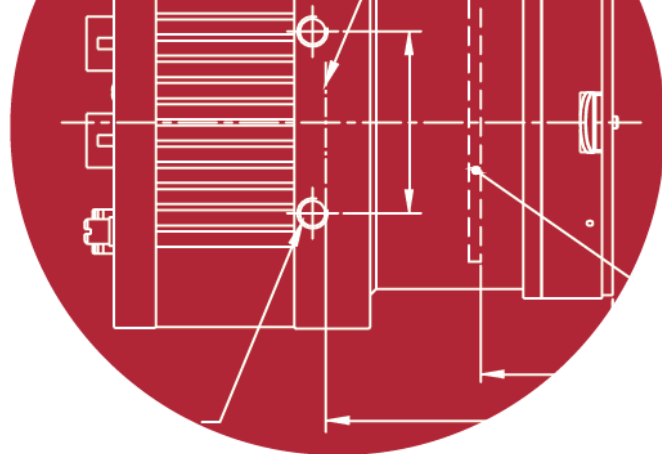

English

VX-25MG

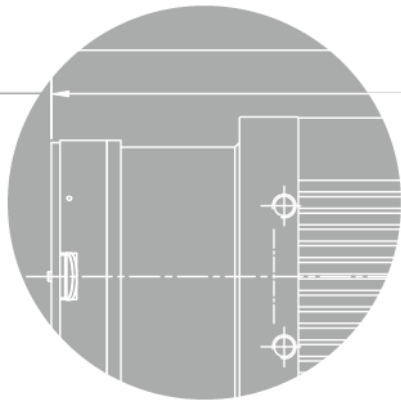

**VIEWWORKS**  
Imaging Expert

**Revision History**

Version	Date	Description
1.0	2017-09-15	Initial Release
1.1	2018-02-23	Corrected the error on the mating connector specifications for Control I/O

# Contents

<b>1</b>	<b>Precautions</b> .....	<b>6</b>
<b>2</b>	<b>Warranty</b> .....	<b>7</b>
<b>3</b>	<b>Compliance &amp; Certifications</b> .....	<b>7</b>
3.1	FCC Compliance .....	7
3.2	CE: DoC .....	7
3.3	KC .....	7
<b>4</b>	<b>Package Components</b> .....	<b>8</b>
<b>5</b>	<b>Product Specifications</b> .....	<b>9</b>
5.1	Model .....	9
5.2	Specifications .....	10
5.3	Camera Block Diagram .....	11
5.4	Spectral Response .....	12
5.5	Mechanical Specification .....	13
<b>6</b>	<b>Installation</b> .....	<b>15</b>
6.1	Mount Plate .....	15
6.2	Precaution to Center the Image Sensor .....	16
6.3	Precaution about Blurring Compared to Center .....	16
6.4	Installing Vieworks Imaging Solution .....	16
<b>7</b>	<b>Camera Interface</b> .....	<b>17</b>
7.1	General Description .....	17
7.2	RJ-45 Jack .....	18
7.3	Control Receptacle .....	19
7.4	Power Input Receptacle .....	20
7.5	Trigger Input Circuit .....	21
7.6	Strobe Output Circuit .....	22
<b>8</b>	<b>Acquisition Control</b> .....	<b>23</b>
8.1	Overview .....	23
8.2	Acquisition Start/Stop Commands and Acquisition Mode .....	26
8.3	Exposure Start Trigger .....	27
8.3.1	Trigger Mode .....	27
8.3.2	Using a Software Trigger Signal .....	30
8.3.3	Using an External Trigger Signal .....	31

8.4	Setting the Exposure Time .....	34
8.4.1	Exposure Auto .....	35
8.5	Overlapping Exposure with Sensor Readout .....	36
8.6	Maximum Allowed Frame Rate .....	39
8.6.1	Increasing the Maximum Allowed Frame Rate .....	40
<b>9</b>	<b>Camera Features .....</b>	<b>41</b>
9.1	Image Region of Interest .....	41
9.2	Binning .....	44
9.3	Exposure Control .....	46
9.3.1	Aperture Control .....	46
9.3.2	Exposure Auto, Gain Auto and Aperture Auto .....	47
9.4	Pixel Format .....	51
9.5	Stream Hold .....	53
9.6	Inter-Packet Delay .....	54
9.7	Data ROI .....	55
9.8	Focus Auto .....	57
9.9	Gain and Black Level .....	58
9.9.1	Digital Domain .....	58
9.10	Defective Pixel Correction .....	59
9.10.1	Correction Method .....	59
9.10.2	Correction Method in Binning Mode .....	60
9.11	Flat Field Correction .....	61
9.12	Temperature Monitor .....	64
9.13	Status LED .....	64
9.14	Test Image .....	65
9.15	Digital IO Control .....	67
9.15.1	Debounce .....	69
9.16	Device User ID .....	69
9.17	Device Reset .....	70
9.18	User Set Control .....	70
9.19	Field Upgrade .....	70
<b>10</b>	<b>Troubleshooting .....</b>	<b>71</b>

---

<b>Appendix A</b>	<b>Defective Pixel Map Download.....</b>	<b>72</b>
<b>Appendix B</b>	<b>Field Upgrade.....</b>	<b>74</b>
B.1	MCU.....	74
B.2	FPGA.....	76
B.3	XML.....	77

# 1 Precautions

## General



- Do not drop, disassemble, repair or alter the device. Doing so may damage the camera electronics and cause an electric shock.
- Do not let children touch the device without supervision.
- Stop using the device and contact the nearest dealer or manufacturer for technical assistance if liquid such as water, drinks or chemicals gets into the device.
- Do not touch the device with wet hands. Doing so may cause an electric shock.
- Make sure that the temperature of the camera does not exceed the temperature range specified in [5.2 Specifications](#). Otherwise the device may be damaged by extreme temperatures.

## Installation and Maintenance



- Do not install in dusty or dirty areas - or near an air conditioner or heater to reduce the risk of damage to the device.
- Avoid installing and operating in an extreme environment where vibration, heat, humidity, dust, strong magnetic fields, explosive/corrosive mists or gases are present.
- Do not apply excessive vibration and shock to the device. This may damage the device.
- Avoid direct exposure to a high intensity light source. This may damage the image sensor.
- Do not install the device under unstable lighting conditions. Severe lighting change will affect the quality of the image produced by the device.
- Do not use solvents or thinners to clean the surface of the device. This can damage the surface finish.

## Power Supply



- Applying incorrect power can damage the camera. If the voltage applied to the camera is greater or less than the camera's nominal voltage, the camera may be damaged or operate erratically. Please refer to [5.2 Specifications](#) for the camera's nominal voltage.
  - ※ Vieworks Co., Ltd. does NOT provide power supplies with the devices.
- Make sure the power is turned off before connecting the power cord to the camera. Otherwise, damage to the camera may result.

## 2 Warranty

Do not open the housing of the camera. The warranty becomes void if the housing is opened.

For information about the warranty, please contact your local dealer or factory representative.

## 3 Compliance & Certifications

### 3.1 FCC Compliance

This equipment has been tested and found to comply with the limits for a Class A digital device, pursuant to part 15 of the FCC Rules. These limits are designed to provide reasonable protection against harmful interference when the equipment is operated in a commercial environment. This equipment generates, uses, and can radiate radio frequency energy and, if not installed and used in accordance with the instruction manual, may cause harmful interference to radio communications. Operation of this equipment in a residential area is likely to cause harmful interference in which case the user will be required to correct the interference at his own expenses.

### 3.2 CE: DoC

EMC Directive 2014/30/EU

EN 55032:2012 (Class A), EN 55024:2010

Class A

### 3.3 KC

#### KCC Statement

Type	Description
<b>Class A</b> (Broadcasting Communication Device for Office Use)	This device obtained EMC registration for office use (Class A), and may be used in places other than home. Sellers and/or users need to take note of this.

## 4 Package Components

### Package Components



VX-25MG with F-mount

VX-25MG with Canon-EF Adapter



Mount Plate (Optional)



M3 Set Screws for Tilt Adjustment (Provided only with F-mount camera)

Interface for Canon-EF adapter (except Canon-EF adapter) option is also available upon request.



- You can adjust the tilt using the M3 set screws, however it is not recommended since it is adjusted as factory default settings.
- If the tilt settings need to be adjusted inevitably, please contact your local dealer or factory representative for technical support.



## 5 Product Specifications

### 5.1 Model

VX series cameras are made for Aerial Imaging and High-end Surveillance applications which require the highest attention to detail. The VX-25MG-5, a new member of the VX series, uses the industrial proven 5,120 × 5,120 CMOS imaging sensor technology and performs as fast as 5 fps with 25 megapixel resolution. This camera provides not only auto exposure, gain and aperture controls but also auto focus and Canon-EF adapter control.

#### Main Features

- 25 Megapixel Resolution (ON Semiconductor CMOS)
- Auto Exposure, Auto Gain, Auto Aperture Controls
- Auto Focus
- Canon-EF adapter Control for Canon EF lens (Optional)
- Stream Hold
- Inter-Packet Delay
- Field Upgradable Firmware
- Pixel Defect Correction

## 5.2 Specifications

Technical specifications of the VX-25MG camera are as follows.

Specification	VX-25MG-5
Active Image (H × V)	5120 × 5120
Sensor Type	ON Semiconductor VITA-25K
Pixel Size	4.5 μm × 4.5 μm
Sensor Output	32 CH LVDS
Video Output	8 bits
Output Format	Mono8
Camera Interface	Gigabit Ethernet
Electronic Shutter	Global Shutter
Max. Frame Rate at Full Resolution	4.7 fps / 25 fps(Burst Mode)
Shutter Speed	1/1,000,000 ~ 60 sec (1 μs step)
Partial Scan (Max. Speed)	13,888 fps at 1 Lines
Binning	×1, ×2 (Horizontal and Vertical Independent)
Black Level	Adjustable (0 ~ 16 LSB, 16 steps)
Digital Gain	×1 ~ ×4 (1/128 step)
Exposure Mode	Timed Exposure, Trigger Width Exposure
External Trigger	3.3 V ~ 24.0 V, 10 mA, Asynchronous, optically isolated
Software Trigger	Asynchronous, Programmable via Camera API
Dynamic Range	54 dB
Camera Image Memory	2 Gb
Lens Mount	F-mount or Interface for Canon-EF adapter
Power	10 ~ 36 V DC, Typ. 7.5 W
Environmental	Operating: -50°C ~ 80°C Storage: -50°C ~ 90°C
Vibration / Shock	10G (20 ~ 200 Hz) XYZ / 70G 10 ms
Mechanical (W × H × L)	68 mm × 68 mm × 80 mm, 420 g (with F-mount) 68 mm × 68 mm × 77 mm, 578 g (with Canon-EF adapter)

**Table 5.1 Specifications of the VX-25MG**

### 5.3 Camera Block Diagram

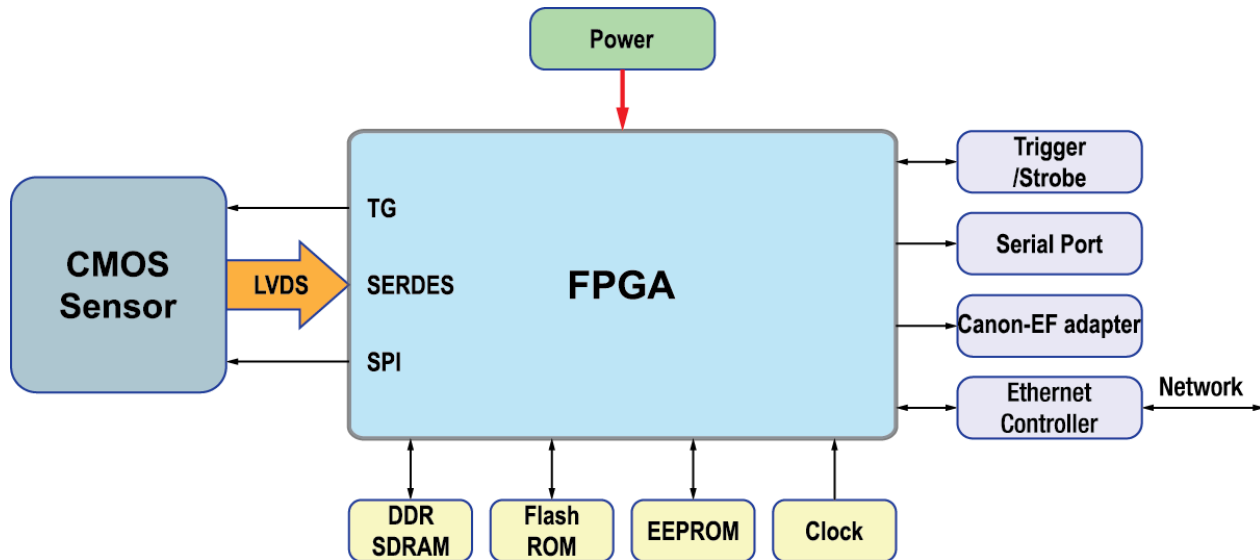

Figure 5.1 Camera Block Diagram

All controls and data processing of the VX-25MG camera are carried out in one FPGA chip. The FPGA generally consists of a 32 bit RISC Microprocessor and Processing & Control Logic. The Microprocessor receives commands from the user through the Gigabit Ethernet interface and then processes them. The Processing & Control Logic processes the image data received from the CMOS sensor and then transmits data through the Gigabit Ethernet interface. And also, the Processing & Control Logic controls the trigger input and output signal which are sensitive to time. Furthermore, a Flash memory for operating the Microprocessor and a DDR2 for used as a frame buffer to process images are installed outside FPGA.

## 5.4 Spectral Response

The following graphs show the spectral response of the VX-25MG monochrome camera.

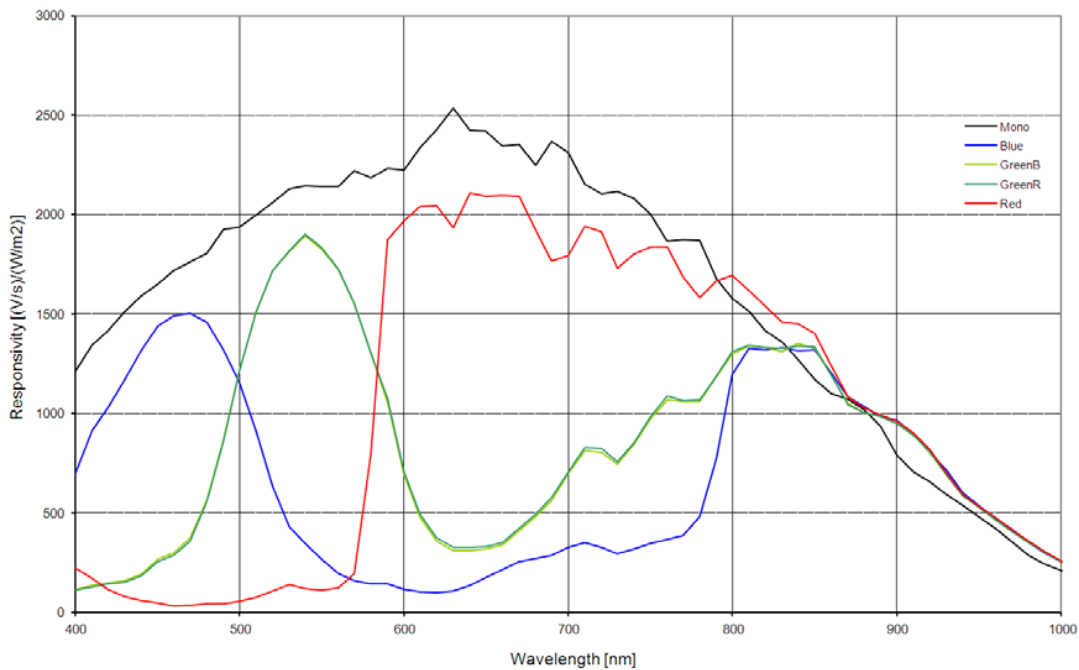
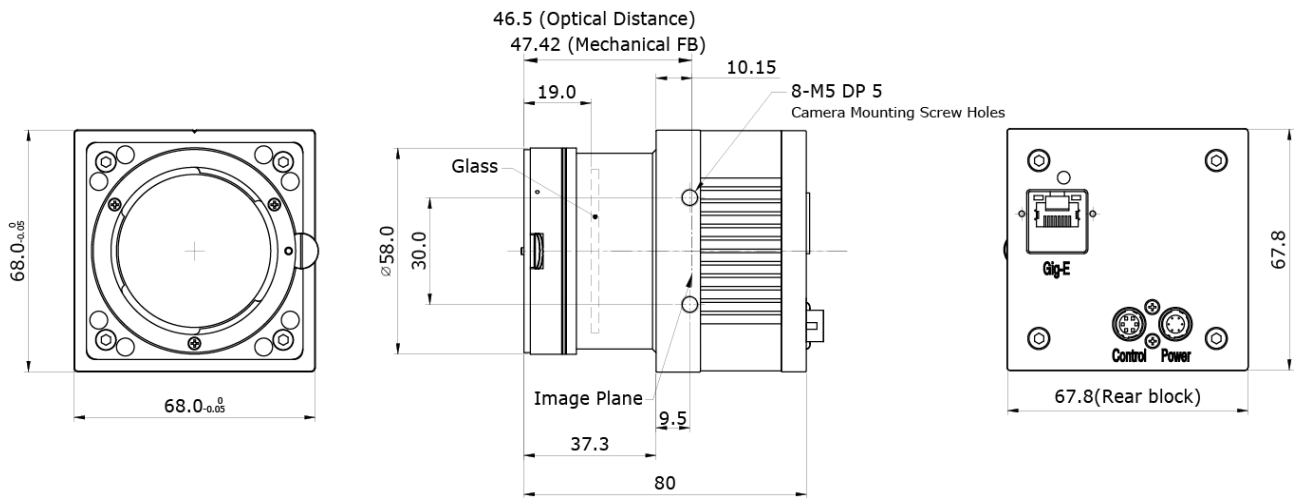

Figure 5.2 VX-25MG Spectral Response

## 5.5 Mechanical Specification

The camera dimensions in millimeters are as shown in the following figure.



**Figure 5.3 VX-25MG Camera F-mount Mechanical Dimension**

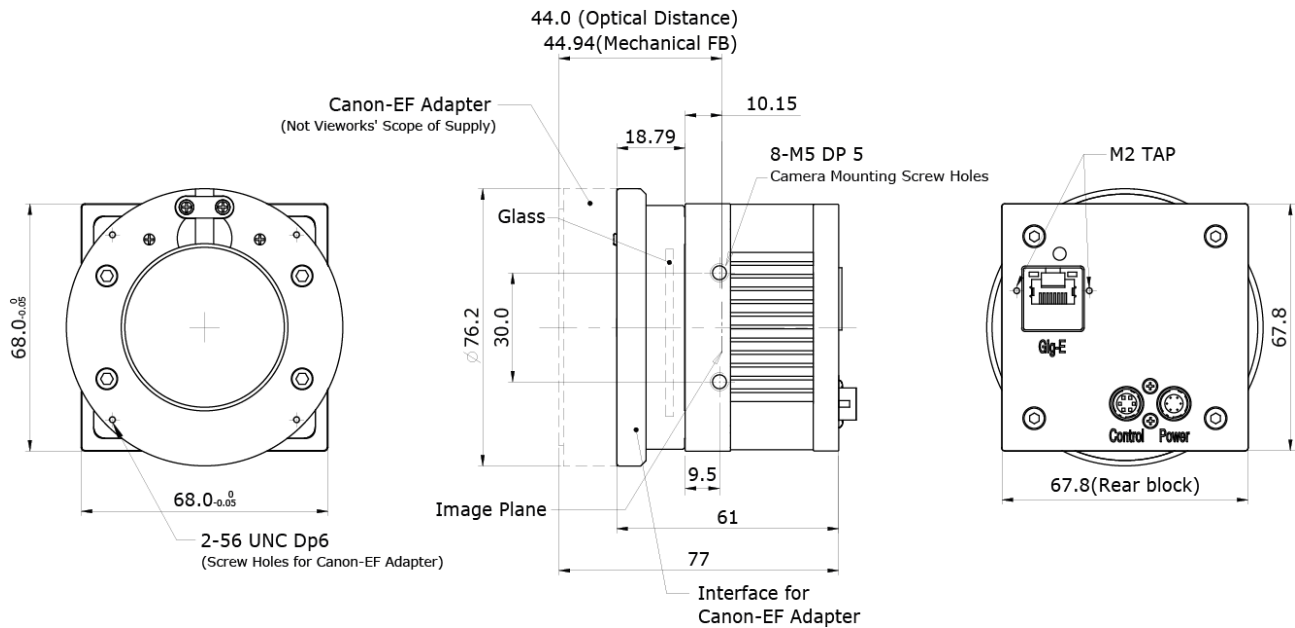

**Figure 5.4 VX-25MG Camera Interface for Canon-EF Adapter (Birger Mount) Mechanical Dimension**

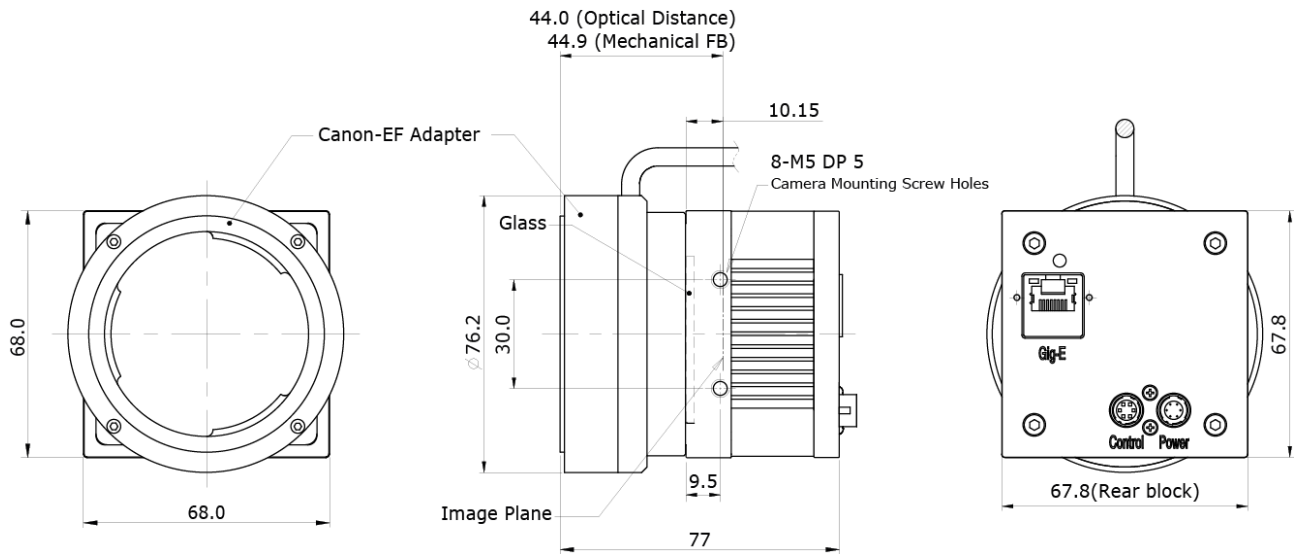

**Figure 5.5 VX-25MG Camera + Canon-EF Adapter (Birger Mount) Mechanical Dimension**



The Canon-EF adapter (Birger Mount) is available upon request (sold separately).

## 6 Installation

The following instructions assume that you have installed an Ethernet Card including related software and **Vieworks Imaging Solution** in your computer. For more information, refer to your Vieworks Imaging Solution Installation Manual.

To connect the camera to your computer, follow the steps below:

1. Make sure that the power supply is not connected to the camera and your computer is turned off.
2. Plug one end of an Ethernet cable into the RJ45 jack on the camera and the other end of the Ethernet cable into the Ethernet Card in your computer.
3. Connect the plug of the power adaptor to the power input receptacle on the camera.
4. Plug the power adaptor into a working electrical outlet.
5. Verify all the cable connections are secure.

### 6.1 Mount Plate

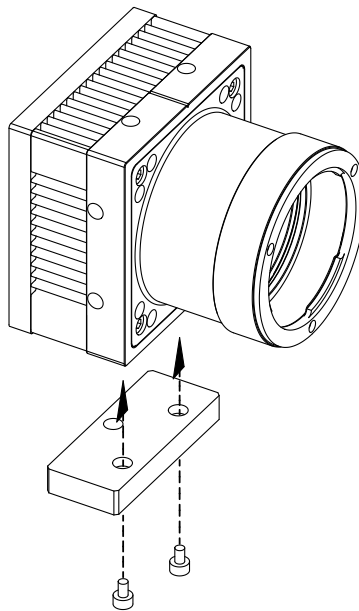

- The Mount Plate is provided as an optional item.
- The camera can be fixed without using this Mount Plate.

## 6.2 Precaution to Center the Image Sensor

- Users do not need to center the image sensor as it is adjusted as factory default settings.
- When you need to adjust the center of the image sensor, please contact your local dealer or the manufacturer for technical assistance.

## 6.3 Precaution about Blurring Compared to Center

- Users do not need to adjust the tilt as it is adjusted as factory default settings.
- If the tilt settings need to be adjusted inevitably, please contact your local dealer or factory representative for technical support.

## 6.4 Installing Vieworks Imaging Solution

You should perform the software installation first and then the hardware installation.

You can download the Vieworks Imaging Solution at <http://www.vieworks.com>.



## 7 Camera Interface

### 7.1 General Description

As shown in the following figure, 3 types of connectors and status indicator LED are located on the back of the camera and have the functions as follows:

- ① Status LED: displays power status and operation mode.
- ② RJ-45 Jack: controls video data and the camera.
- ③ 6 pin Control Receptacle: inputs external trigger signal and outputs strobe.
- ④ 6 pin Power Input Receptacle: supplies power to the camera.

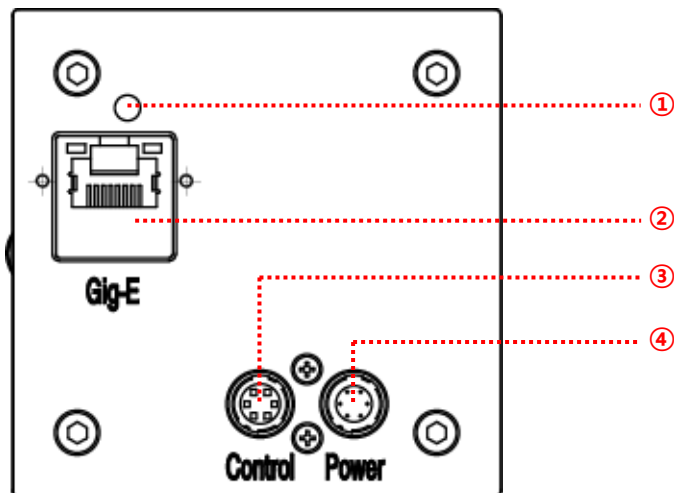

Figure 7.1 VX-25MG Back Panel

## 7.2 RJ-45 Jack

The 8-pin RJ-45 jack provides Ethernet access to the camera. Pin assignments for the RJ-45 jack adhere to the Ethernet standard.

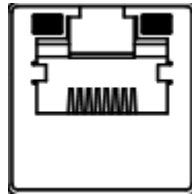

Figure 7.2 RJ-45 Jack

PAIR List	Pin	Signal Name	Type	Description
PAIR 0	1	+TXA	Differential	Gigabit Ethernet Transceiver
	2	-TXA	Differential	Gigabit Ethernet Transceiver
PAIR 1	3	+TXB	Differential	Gigabit Ethernet Transceiver
	6	-TXB	Differential	Gigabit Ethernet Transceiver
PAIR 2	4	+TXC	Differential	Gigabit Ethernet Transceiver
	5	-TXC	Differential	Gigabit Ethernet Transceiver
PAIR 3	7	+TXD	Differential	Gigabit Ethernet Transceiver
	8	-TXD	Differential	Gigabit Ethernet Transceiver

Table 7.1 Pin Assignments for the RJ-45 Jack

## 7.3 Control Receptacle

The control receptacle is a Hirose 6 pin connector (part # HR10A-7R-6SB) and consists of an external trigger signal input and strobe output port. The pin assignments and configurations are as follows:

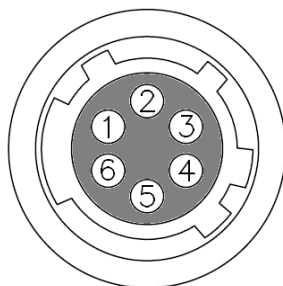

**Figure 7.3 Pin Assignments for 6 Pin Control Receptacle**

Pin Number	Signal	Type	Description
1	Trigger Input +	Input	Voltage difference of 3.3 V ~ 24.0 V, 10 mA, optically isolated
2	Trigger Input -	Input	
3	Programmable Output (Default: Strobe Out)	Output	3.3 V TTL Output Output resistance : 47 Ω
4	DC Ground	-	DC Ground
5	RS-232 RX	Input	Canon-EF adapter interface
6	RS-232 TX	Output	Canon-EF adapter interface

**Table 7.2 Pin Arrangement of Control Receptacle**

The mating connector is a Hirose 6 pin plug (part # HR10A-7P-6P) or the equivalent connectors.

## 7.4 Power Input Receptacle

The power input receptacle is a Hirose 6 pin connector (part # HR10A-7R-6PB). The pin assignments and configurations are as follows:

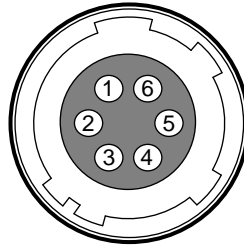

Figure 7.4 Pin Assignments for Power Input Receptacle

Pin Number	Signal	Type	Description
1, 2, 3	+ 12V DC	Input	DC Power Input
4, 5, 6	DC Ground	Input	DC Ground

Table 7.3 Pin Configurations for Power Input Receptacle

Connecting the power cable to the camera can be made by using the Hirose 6 pin plug (part # HR10A-7P-6S) or the equivalent. The power adaptor is recommended to have at least 1A current output at 12 V DC  $\pm 10\%$  voltage output (Users need to purchase the power adaptor separately).

### Precaution for Power Input



- Make sure the power is turned off before connecting the power cord to the camera. Otherwise, damage to the camera may result.
- If voltage applied to the camera exceeds the camera's input voltage limit, damage to the camera may result.

## 7.5 Trigger Input Circuit

The following figure shows trigger signal input circuit of the 6-pin connector. Transmitted trigger signal is applied to the internal circuit through a photo coupler. The VX-25MG camera allows you to adjust the trigger width which can be recognized by the camera (refer to [9.16.1 Debounce](#)). The voltage requirements that are acceptable for trigger signals are as follows:

Camera	Voltage Requirements for Trigger Input
VX-25MG	3.3 – 24.0 V

**Table 7.4 Voltage Requirements for Trigger Input**

An example circuit of an external trigger input is shown below.

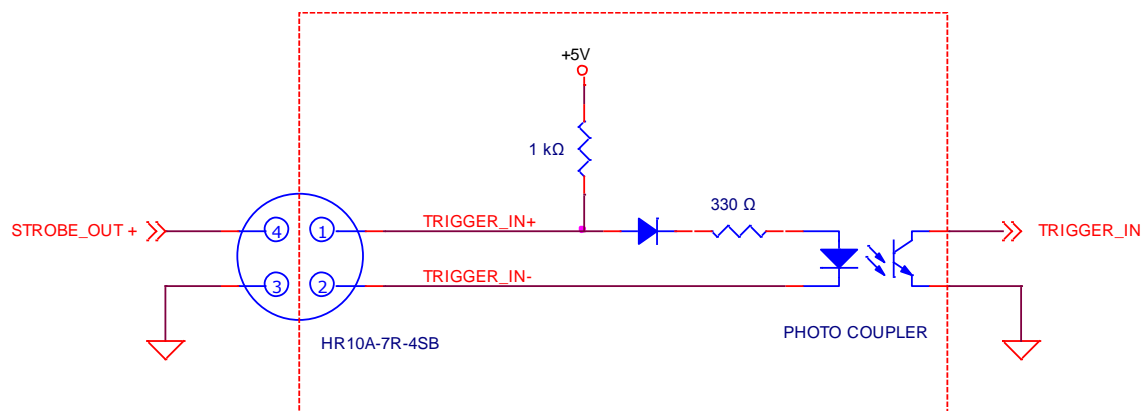

**Figure 7.5 VX-25MG Trigger Input Schematic**

## 7.6 Strobe Output Circuit

The strobe output signal comes out through a 3.3 V output level of Line Driver IC. You can change the strobe output by setting the Digital IO Control (Refer to chapter [9.15 Digital IO Control](#)).

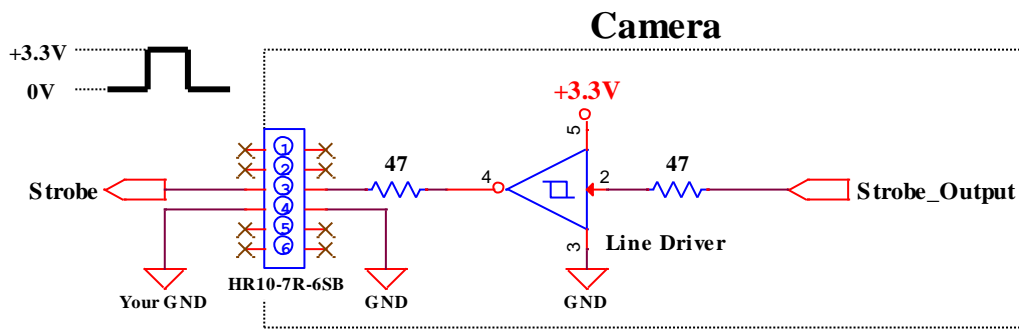

Figure 7.6 Strobe Output Schematic

## 8 Acquisition Control

This chapter provides detailed information about controlling image acquisition.

- Triggering image acquisition
- Setting the exposure time
- Controlling the camera's image acquisition rate
- Variation of the camera's maximum allowed image acquisition rate according to the camera settings

### 8.1 Overview

This section presents an overview of the elements involved with controlling the acquisition of images.

Three major elements are involved in controlling the acquisition of images:

- **Acquisition Start** and **Acquisition Stop** commands and the **Acquisition Mode** parameter
- The exposure start trigger
- Exposure time control



When reading the explanations in the overview and in this entire chapter, keep in mind that the term **frame** is typically used to mean a single acquired image.

#### Acquisition Start and Stop Commands and the Acquisition Mode

The **Acquisition Start** command prepares the camera to acquire frames. The camera cannot acquire frames unless an **Acquisition Start** command has first been executed.

A parameter called the **Acquisition Mode** has a direct bearing on how the **Acquisition Start** command operates.

If the **Acquisition Mode** parameter is set to **Single Frame**, you can only acquire one frame after executing an **Acquisition Start** command. When one frame has been acquired, the **Acquisition Start** command will expire. Before attempting to acquire another frame, you must execute a new **Acquisition Start** command.

If the **Acquisition Mode** parameter is set to **Continuous**, an **Acquisition Start** command does not expire after a single frame is captured. Once an **Acquisition Start** command has been executed, you can acquire as many frames as you like. The **Acquisition Start** command will remain in effect until you execute an **Acquisition Stop** command. Once an **Acquisition Stop** command has been executed, the camera will not be able to acquire frames until a new **Acquisition Start** command is executed.

## Exposure Start Trigger

Applying an exposure start trigger signal to the camera will exit the camera from the *waiting for exposure start trigger* acquisition status and will begin the process of exposing and reading out a frame (see Figure 8.1). As soon as the camera is ready to accept another exposure start trigger signal, it will return to the *waiting for exposure start trigger* acquisition status. A new exposure start trigger signal can then be applied to the camera to begin another frame exposure.

The exposure start trigger has two modes: off and on.

If the **Trigger Mode** parameter is set to **Off**, the camera will generate all required exposure start trigger signals internally, and you do not need to apply exposure start trigger signals to the camera. The rate at which the camera will generate the signals and acquire frames will be determined by the way that you set several frame rate related parameters.

If the **Trigger Mode** parameter is set to **On**, you must trigger exposure start by applying exposure start trigger signals to the camera. Each time a trigger signal is applied, the camera will begin a frame exposure. When exposure start is being triggered in this manner, it is important that you do not attempt to trigger frames at a rate that is greater than the maximum allowed (There is a detailed explanation about the maximum allowed frame rate at the end of this chapter.). Exposure start trigger signals applied to the camera when it is not in a *waiting for exposure start trigger* acquisition status will be ignored.

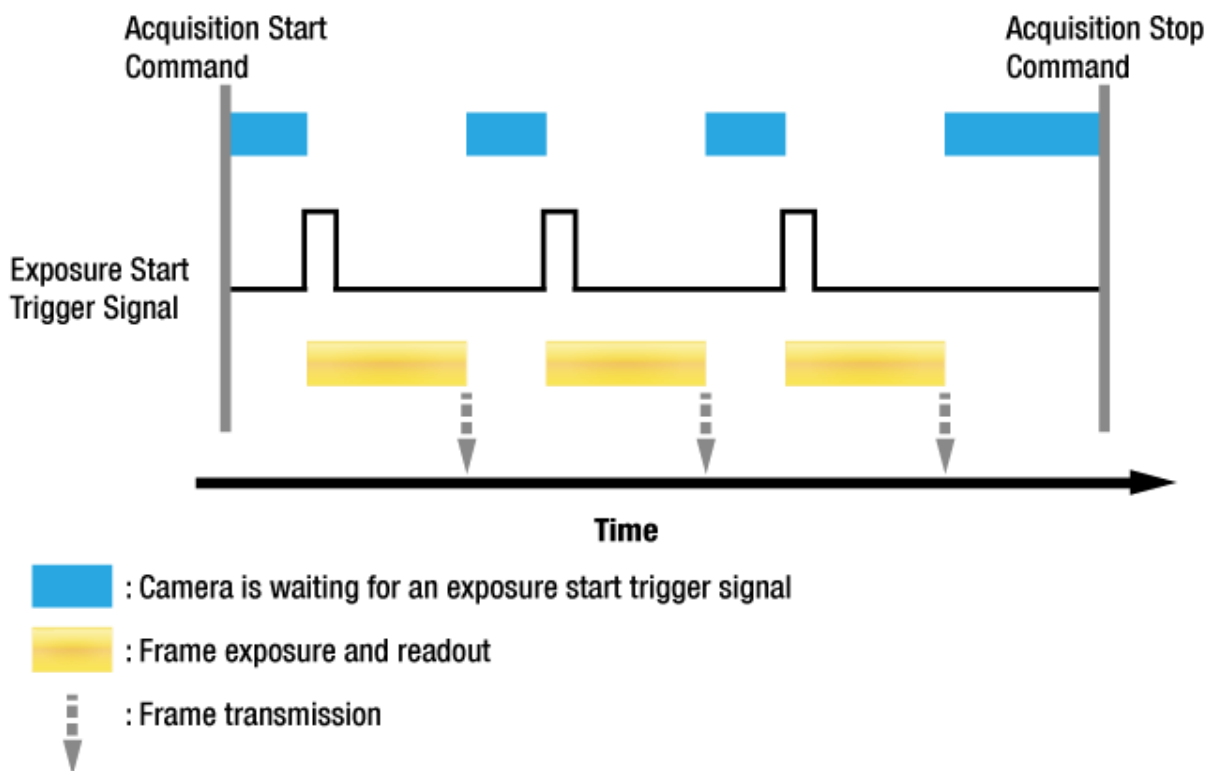

Figure 8.1 Exposure Start Triggering



## Applying Trigger Signals

The paragraphs above mention "applying a trigger signal". There are three ways to apply an exposure start trigger signal to the camera: via **Software**, via **External** (commonly referred to as hardware) or via **User Output 0**.

To apply trigger signals via **Software**, you must set the **Trigger Source** parameter to **Software**. At that point, each time a **Trigger Software** command is executed, the exposure start trigger signal will be applied to the camera.

To apply trigger signals via **External**, you must set the **Trigger Source** parameter to **External**. At that point, each time a proper electrical signal is applied to the camera, an occurrence of the exposure start trigger signal will be recognized by the camera.

To apply trigger signals via **User Output 0**, you must set the **Trigger Source** parameter to **User Output 0**. At the point, you can apply an exposure start trigger signal to the camera by switching the **User Output Value** parameter in the **Digital IO Control** category between **On** (rise) and **Off** (fall).

## Exposure Time Control

When an exposure start trigger signal is applied to the camera, the camera will begin to acquire a frame.

A critical aspect of frame acquisition is how long the pixels in the camera's sensor will be exposed to light during the frame acquisition.

If the **Trigger Source** parameter is set to **Software**, a parameter called the **Exposure Time** will determine the exposure time for each frame. At this point, you must set the **Exposure Mode** parameter to **Timed**.

If the **Trigger Source** parameter is set to **External** or **User Output 0**, there are two modes of operation: **Timed** and **Trigger Width**.

With the **Timed** mode, the **Exposure Time** parameter will determine the exposure time for each frame.

With the **Trigger Width** mode, the way that you manipulate the rise and fall of the external signal will determine the exposure time. The **Trigger Width** mode is especially useful if you want to change the exposure time from frame to frame.

## 8.2 Acquisition Start/Stop Commands and Acquisition Mode

Executing an **Acquisition Start** command prepares the camera to acquire frames. You must execute an **Acquisition Start** command before you can begin acquiring frames. Executing an **Acquisition Stop** command terminates the camera's ability to acquire frames. When the camera receives an **Acquisition Stop** command:

- If the camera is not in the process of acquiring a frame, its ability to acquire frames will be terminated immediately.
- If the camera is in the process of acquiring a frame, the frame acquisition process will be allowed to finish and the camera's ability to acquire new frames will be terminated.

The camera's **Acquisition Mode** parameter has three settings: **Single Frame**, **Multi-Frame** and **Continuous**. The use of **Acquisition Start** and **Acquisition Stop** commands and the camera's **Acquisition Mode** parameter setting are related.

If the camera's **Acquisition Mode** parameter is set to **Single Frame**, after an **Acquisition Start** command has been executed, a single frame can be acquired. When acquisition of one frame is complete, the camera will execute an **Acquisition Stop** command internally and will no longer be able to acquire frames. To acquire another frame, you must execute a new **Acquisition Start** command.

If the camera's **Acquisition Mode** parameter is set to **Multi-Frame**, after an **Acquisition Start** command has been executed, exposure start can be triggered as many as specified by the **Acquisition Frame Count** parameter. The camera will continue to react to exposure start trigger signals until the number of exposure start trigger signals it has received is equal to the current **Acquisition Frame Count** parameter setting. At that point, the **Acquisition Start** command will expire. Before attempting to acquire another frame, you must execute a new **Acquisition Start** command.



With **Single Frame** or **Multi-Frame Acquisition Mode**, if you execute another **Acquisition Start** command while the camera is in the process of acquiring a frame, an error may occur.

If the camera's **Acquisition Mode** parameter is set to **Continuous**, after an **Acquisition Start** command has been executed, exposure start can be triggered as desired. Each time an exposure start trigger is applied while the camera is in a waiting for *exposure start trigger* acquisition status, the camera will acquire and transmit a frame. The camera will retain the ability to acquire frames until an **Acquisition Stop** command is executed. Once the **Acquisition Stop** command is received, the camera will no longer be able to acquire frames.

When the camera's **Acquisition Mode** is set to **Single Frame**, the maximum possible acquisition frame rate for a given ROI cannot be achieved. This is true because the camera performs a complete internal setup cycle for each single frame and because it cannot be operated with **Trigger Overlap**. To achieve the maximum possible acquisition frame rate, set the **Acquisition Mode** to **Continuous** and **Trigger Overlap** to **Readout**.

## 8.3 Exposure Start Trigger

The exposure start trigger is used to begin frame acquisition. Exposure start trigger signals can be generated within the camera or may be applied externally as **Software**, **External** or **User Output 0** exposure start trigger signals. If an exposure start trigger signal is applied to the camera, the camera will begin to expose a frame.

### 8.3.1 Trigger Mode

The main parameter associated with the exposure start trigger is the **Trigger Mode** parameter. The **Trigger Mode** parameter for the exposure start trigger has two available settings: **Off** and **On**.

#### 8.3.1.1 Trigger Mode = Off

When the **Trigger Mode** parameter is set to **Off**, the camera will generate all required exposure start trigger signals internally, and you do not need to apply exposure start trigger signals to the camera.

With the **Trigger Mode** set to **Off**, the way that the camera will operate the exposure start trigger depends on the setting of the camera's **Acquisition Mode** parameter:

- **Single Frame:** The camera will automatically generate a single exposure start trigger signal whenever it receives an **Acquisition Start** command.
- **Multi-Frame:** The camera will automatically begin generating exposure start trigger signals as many as specified by the **Acquisition Frame Count** parameter when it receives an **Acquisition Start** command. The camera will continue to generate exposure start trigger signals until the number of exposure start trigger signals it has received is equal to the current **Acquisition Frame Count** parameter setting or until it receives an **Acquisition Stop** command.



With **Single Frame** or **Multi-Frame Acquisition Mode**, if you execute another **Acquisition Start** command while the camera is in the process of acquiring a frame, an error may occur.



When the **Acquisition Mode** parameter is set to **Multi-Frame**, you must set the value of the camera's **Acquisition Frame Count** parameter. The value of the **Acquisition Frame Count** can range from 1 to 255.

- **Continuous:** The camera will automatically begin generating exposure start trigger signals when it receives an **Acquisition Start** command. The camera will continue to generate exposure start trigger signals until it receives an **Acquisition Stop** command.



#### Free Run

- When you set the **Trigger Mode** parameter to **Off** and the **Acquisition Mode** parameter to **Continuous**, the camera will generate all required trigger signals internally. When the camera is set this way, it will constantly acquire images without any need for triggering by the user. This use case is commonly referred to as “free run”.
- When you operate the camera in free run, you must set the **Trigger Overlap** parameter to **Readout** to achieve optimal camera performance.

The rate at which the exposure start trigger signals are generated may be determined by the camera's **Acquisition Frame Rate** parameter:

- If the parameter is set to a value less than the maximum allowed frame rate with the current camera settings, the camera will generate exposure start trigger signals at the rate specified by the parameter setting.
- If the parameter is set to a value greater than the maximum allowed frame rate with the current camera settings, the camera will generate exposure start trigger signals at the maximum allowed frame rate.

### Exposure Time Control with Trigger Mode = Off

When the Trigger Mode parameter is set to **Off**, the exposure time for each frame acquisition is determined by the value of the camera's **Exposure Time** parameter. For more information about the **Exposure Time** parameter, see [8.4 Setting the Exposure Time](#).

### 8.3.1.2 Trigger Mode = On

When the **Trigger Mode** parameter is set to **On**, you must apply an exposure start trigger signal to the camera each time you want to begin a frame acquisition. The **Trigger Source** parameter specifies the source signal that will act as the exposure start trigger signal.

The available settings for the **Trigger Source** parameter are:

- **Software:** You can apply an exposure start trigger signal to the camera by executing a **Trigger Software** command for the exposure start trigger on your computer.
- **External:** You can apply an exposure start trigger signal to the camera by injecting an externally generated electrical signal (commonly referred to as a hardware trigger signal) into the Control Receptacle pin 1 on the camera.
- **User Output 0:** You can apply an exposure start trigger signal to the camera by switching the **User Output Value** parameter between **On** and **Off** on your computer.

If the **Trigger Source** parameter is set to **External** or **User Output 0**, you must also set the **Trigger Activation** parameter.

The available settings for the **Trigger Activation** parameter are:

- **Rising Edge:** Specifies that a rising edge of the electrical signal will act as the exposure start trigger.
- **Falling Edge:** Specifies that a falling edge of the electrical signal will act as the exposure start trigger.

### Exposure Time Control with Trigger Mode = On

When the **Trigger Mode** parameter is set to **On** and the **Trigger Source** parameter is set to **Software**, the exposure time for each frame acquisition is determined by the value of the camera's **Exposure Time** parameter.

When the **Trigger Mode** parameter is set to **On** and the **Trigger Source** parameter is set to **External**, the exposure time for each frame acquisition will be determined by the **Exposure Mode** parameter settings as follows:

- **Exposure Mode = Timed:** Exposure time can be controlled with the **Exposure Time** parameter
- **Exposure Mode = Trigger Width:** Exposure time can be controlled by manipulating the external trigger signal

When the **Trigger Mode** parameter is set to **On** and the **Trigger Source** parameter is set to **User Output 0**, the exposure time for each frame acquisition will be determined by the **Exposure Mode** parameter settings as follows:

- **Exposure Mode = Timed:** Exposure time can be controlled with the **Exposure Time** parameter
- **Exposure Mode = Trigger Width:** Exposure time can be controlled by switching the **User Output Value** parameter between **On** and **Off**

### 8.3.2 Using a Software Trigger Signal

If the **Trigger Mode** parameter is set to **On** and the **Trigger Source** parameter is set to **Software**, you must apply a software trigger signal (exposure start) to the camera to begin each frame acquisition. Assuming that the camera is in a *waiting for exposure start trigger* acquisition status, frame exposure will start when the software trigger signal is received by the camera. Figure 8.2 illustrates frame acquisition with a software trigger signal.

When the camera receives a software trigger signal and begins exposure, it will exit the *waiting for exposure start trigger* acquisition status because at that point, it cannot react to a new exposure start trigger signal.

As soon as the camera is capable of reacting to a new exposure start trigger signal, it will automatically return to the *waiting for exposure start trigger* acquisition status.

When you are using a software trigger signal to start each frame acquisition, the camera's **Exposure Mode** parameter must be set to **Timed**. The exposure time for each acquired frame will be determined by the value of the camera's **Exposure Time** parameter.



When you use a software trigger signal to acquire frames, be aware that there is a Trigger Latency due to the characteristics of the Gigabit Ethernet. Use an external trigger signal to precisely synchronize the trigger signal with the exposure timing.

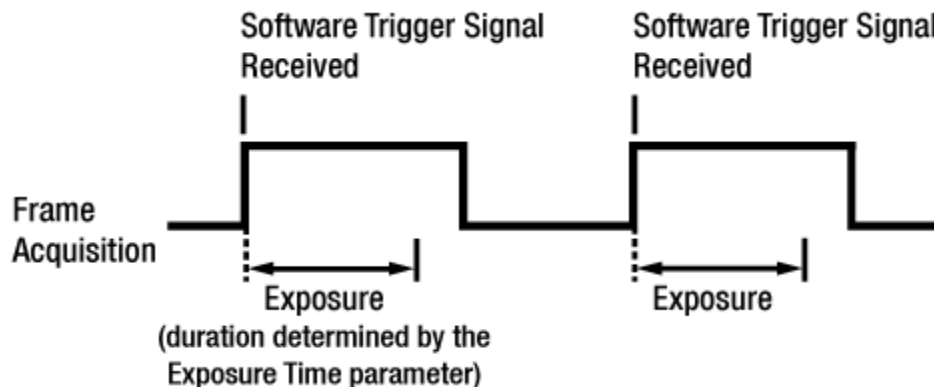

**Figure 8.2 Frame Acquisition with Software Trigger Signal**

When you are using a software trigger signal to start each frame acquisition, the frame rate will be determined by how often you apply a software trigger signal to the camera, and you should not attempt to trigger frame acquisition at a rate that exceeds the maximum allowed for the current camera settings. (There is a detailed explanation about the maximum allowed frame rate at the end of this chapter.)

(There is a detailed explanation about the maximum allowed frame rate at the end of this chapter.)

Software trigger signals that are applied to the camera when it is not ready to receive them will be ignored.

### 8.3.3 Using an External Trigger Signal

If the **Trigger Mode** parameter is set to **On** and the **Trigger Source** parameter is set to **External**, an externally generated electrical signal injected into the Control Receptacle pin 1 will act as the exposure start trigger signal for the camera. This type of trigger signal is generally referred to as a hardware trigger signal.

A rising edge or a falling edge of the external signal can be used to trigger frame acquisition. The **Trigger Activation** parameter is used to select rising edge or falling edge triggering.

Assuming that the camera is in a *waiting for exposure start trigger* acquisition status, frame acquisition will start whenever the appropriate edge transition is received by the camera.

When the camera receives an external trigger signal and begins exposure, it will exit the *waiting for exposure start trigger* acquisition status because at that point, it cannot react to a new exposure start trigger signal. As soon as the camera is capable of reacting to a new exposure start trigger signal, it will automatically return to the *waiting for exposure start trigger* acquisition status.

When the camera is operating under control of an external signal, the period of the external trigger signal will determine the rate at which the camera is acquiring frames:

$$\frac{1}{\text{External signal period in seconds}} = \text{Frame Rate}$$

For example, if you are operating a camera with an External trigger signal period of 500 ms (0.5 s):

So in this case, the frame rate is 2 fps.

### 8.3.3.1 Exposure Modes

If you are triggering the start of frame acquisition with an externally generated trigger signal, two exposure modes are available: **Timed** and **Trigger Width**.

#### Timed Exposure Mode

When the **Timed** mode is selected, the exposure time for each frame acquisition is determined by the value of the camera's **Exposure Time** parameter. If the camera is set for rising edge triggering, the exposure time starts when the external trigger signal rises. If the camera is set for falling edge triggering, the exposure time starts when the external trigger signal falls. Figure 8.3 illustrates timed exposure with the camera set for rising edge triggering.

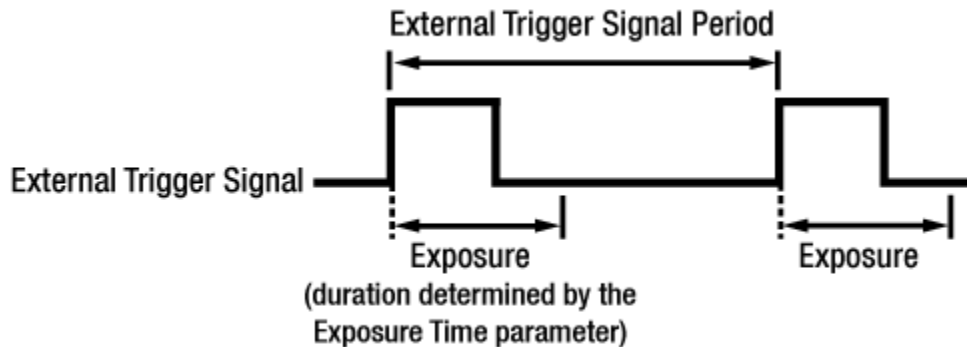

Figure 8.3 Timed Exposure Mode

Note that if you attempt to trigger a new exposure start while the previous exposure is still in progress, the trigger signal will be ignored, and an Over-trigger event will be generated.

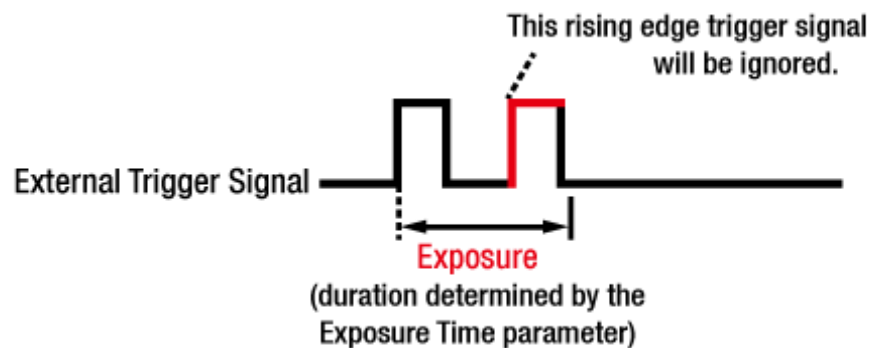

Figure 8.4 Trigger Overlapped with Timed Exposure Mode



## Trigger Width Exposure Mode

When the **Trigger Width** exposure mode is selected, the length of the exposure for each frame acquisition will be directly controlled by the external trigger signal. If the camera is set for rising edge triggering, the exposure time begins when the external trigger signal rises and continues until the external trigger signal falls. If the camera is set for falling edge triggering, the exposure time begins when the external trigger signal falls and continues until the external trigger signal rises. Figure 8.5 illustrates **Trigger Width** exposure with the camera set for rising edge triggering.

**Trigger Width** exposure is especially useful if you intend to vary the length of the exposure time for each frame.

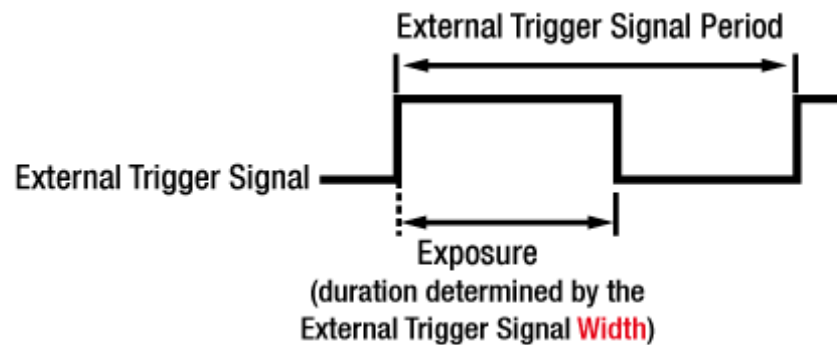

Figure 8.5 Trigger Width Exposure Mode

## 8.4 Setting the Exposure Time

This section describes how the exposure time can be adjusted manually by setting the value of the exposure time parameter. The camera also has an **Exposure Auto** feature that can automatically adjust the exposure time.



Manual adjustment of the exposure time parameter will only work correctly if the **Exposure Auto** feature is disabled.

If you are operating the camera in any one of the following ways, you must specify an exposure time by setting the camera's **Exposure Time** parameter:

- the **Trigger Mode** is set to off
- the **Trigger Mode** is set to **On** and the **Trigger Source** is set to **Software** (In this case, you must set the **Exposure Mode** parameter to **Timed**.)
- the **Trigger Mode** is set to **On**, the **Trigger Source** is set to **External**, and the **Exposure Mode** is set to **Timed**.

The **Exposure Time** parameter must not be set below a minimum specified value. The **Exposure Time** parameter sets the exposure time in  $\mu s$ . The minimum and maximum exposure time settings for the VX-25MG camera are shown in the following table.

Camera Model	Minimum Allowed Exposure Time	Maximum Possible Exposure Time <sup>†</sup>
VX-25MG	1 $\mu s$	60,000,000 $\mu s$

<sup>†</sup>: When the **Exposure Mode** is set to **Trigger Width**, the exposure time is controlled by the external trigger signal and has no maximum limit.

**Table 8.1 Minimum and Maximum Exposure Time Setting**

### 8.4.1 Exposure Auto

The **Exposure Auto** feature automatically adjusts the **Exposure Time** parameter within set limits until an average gray value for the pixel data from the **AE ROI** reaches an **Exposure Auto Target Level** setting value.

The **Exposure Auto** feature can be operated in the **Once** or **Continuous** modes of operation.

If the **AE ROI** does not overlap the Image ROI, the pixel data from the Data ROI will not be used to control the exposure time.

The **Exposure Auto** feature and the **Gain Auto** feature can be used at the same time.

When the **Trigger Width** parameter is selected for **Exposure Mode**, the **Exposure Auto** feature is not available.

For more information, refer to [9.3.2 Exposure Auto, Aperture Auto and Gain Auto](#).

## 8.5 Overlapping Exposure with Sensor Readout

The frame acquisition process on the camera includes two distinct parts. The first part is the exposure of the pixels in the imaging sensor. Once exposure is complete, the second part of the process – readout of the pixel values from the sensor – takes place. In regard to this frame acquisition process, there are two common ways for the camera to operate: with **Trigger Overlap – Off** and with **Trigger Overlap - Readout**.

In the **Trigger Overlap – Off** mode of operation, each time a frame is acquired the camera completes the entire exposure/readout process before acquisition of the next frame is started. The exposure for a new frame does not overlap the sensor readout for the previous frame. Figure 8.6 illustrates the **Trigger Overlap** parameter set to **Off** and the **Exposure Mode** parameter set to **Trigger Width**.

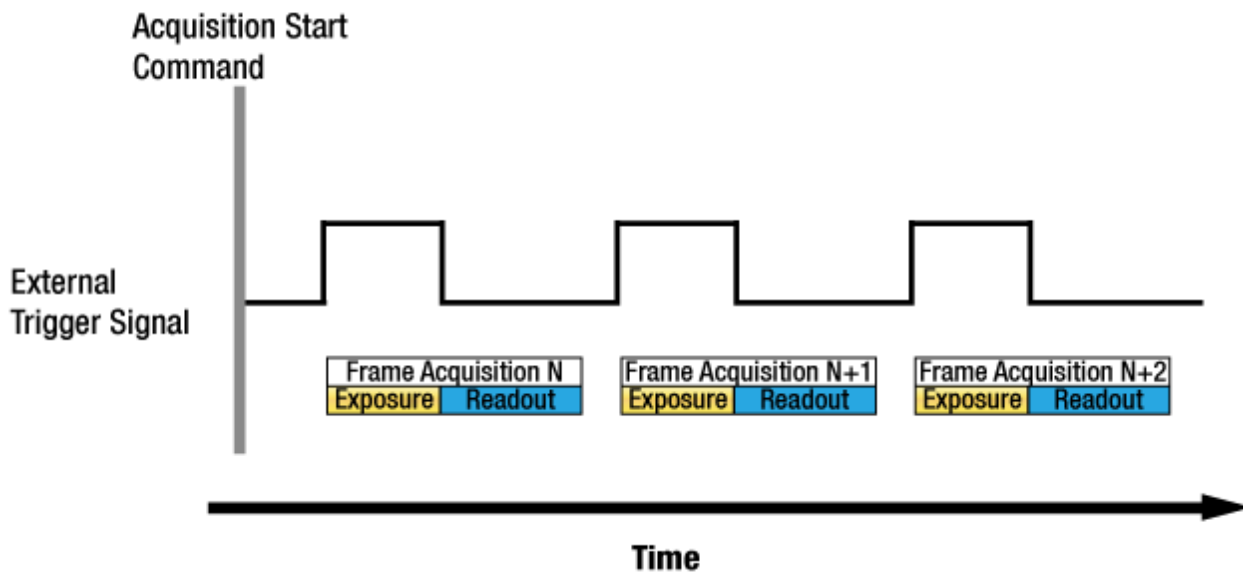
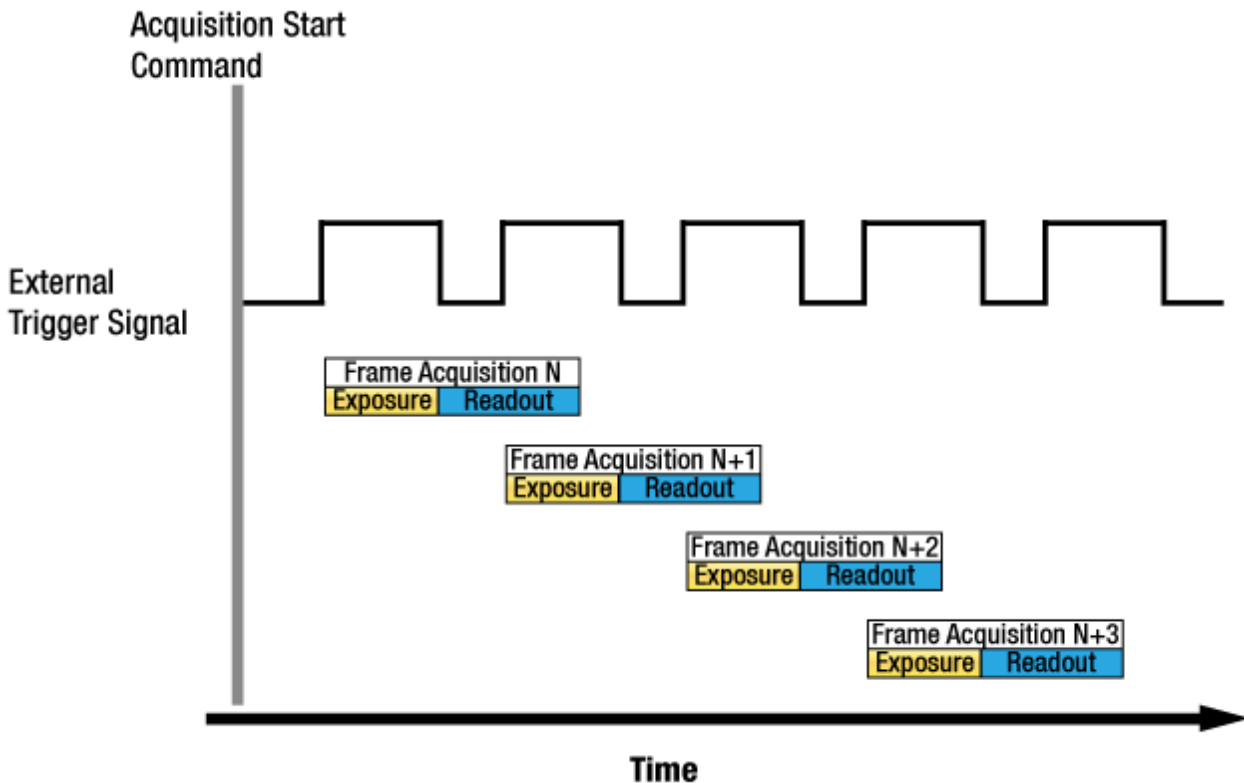

Figure 8.6 Trigger Overlap - Off

In the **Trigger Overlap – Readout** mode of operation, the exposure of a new frame begins while the camera is still reading out the sensor data for the previously acquired frame. Figure 8.7 illustrates the **Trigger Overlap** parameter set to **Readout** and the **Exposure Mode** parameter set to **Trigger Width**.



**Figure 8.7 Trigger Overlap - Readout**

Determining whether your camera is operating with overlapped or non-overlapped exposure and readout is not a matter of issuing a command or switching a setting on or off. Rather the way that you operate the camera will determine whether the exposures and readouts are overlapped or not.

If we define the “Frame Period” as the time from the start of exposure for one frame acquisition to the start of exposure for the next frame acquisition, then:

- Non-overlapped:  $\text{Frame Period} \geq \text{Exposure Time} + \text{Readout Time}$
- Overlapped:  $\text{Frame Period} \leq \text{Exposure Time} + \text{Readout Time}$

## Guidelines for Overlapped Exposure

If you will be operating the camera with overlapped exposure, there are two important guidelines to keep in mind:

- You must not begin the exposure time for a new image acquisition while the exposure time of the previous acquisition is in progress.
- You must not end the exposure time of the current image acquisition until readout of the previously acquired image is complete.

When you are operating a camera with overlapped exposure and using an external trigger signal to trigger image acquisition, you could use the camera's Exposure Time parameter settings and timing formulas to calculate when it is safe to begin each new acquisition.



The exposure must always begin on an interline boundary of the CMOS sensor. For this reason, if a trigger signal is applied during the readout process, there might be an Exposure Start Delay up to 1 horizontal line time.

## 8.6 Maximum Allowed Frame Rate

In general, the maximum allowed acquisition frame rate on the camera may be limited by several factors:

- The amount of time that it takes to transmit an acquired frame from the camera to your computer.  
The amount of time needed to transmit a frame depends on the bandwidth assigned to the camera.
- The **Binning** feature. If binning is enabled, the maximum allowed frame rate will increase.
- The amount of time it takes to read an acquired frame out of the imaging sensor and into the camera's frame buffer. This time varies depending on the setting for the **Height** parameter. Frames with a smaller height take less time to read out of the sensor. The frame height is determined by the camera's **Height** settings (Image Format Control).
- The exposure time for acquired frames. If you use very long exposure times, you can acquire fewer frames per second.



When the camera's **Acquisition Mode** is set to **Single Frame**, the maximum possible acquisition frame rate for a given ROI cannot be achieved. This is true because the camera performs a complete internal setup cycle for each single frame and because it cannot be operated with Trigger Overlap – Readout mode.

To achieve the maximum possible acquisition frame rate, set the **Acquisition Mode** parameter to **Continuous** and the **Trigger Overlap** parameter to **Readout**.

## 8.6.1 Increasing the Maximum Allowed Frame Rate

You may find that you would like to acquire frames at a rate higher than the maximum allowed with the camera's current settings. In this case, you must adjust one or more of the factors that can influence the maximum allowed frame rate and then check to see if the maximum allowed frame rate has increased:

- The time that it takes to transmit a frame out of the camera is the main limiting factor on the frame rate. You can decrease the frame transmission time (and thus increase the maximum allowed frame rate) by doing one or more of the following:
  - Use a smaller ROI. Decreasing the ROI means that the camera has less data to transmit and therefore the transmission time will decrease.
  - Use binning. When pixels are binned, there is less data to transmit and therefore the transmission time will decrease.
  - Make sure that the Packet Size (GevSCPSPacketSize) parameter is set as high as possible for your system and that the Inter-Packet delay (GevSCPD) parameter is set as low as possible.
- If you are using normal exposure times and you are using the camera at its maximum resolution, your exposure time will not normally restrict the frame rate. However, if you are using long exposure times or small region of interest, it is possible that your exposure time is limiting the maximum allowed frame rate. If you are using a long exposure time or a small ROI, try using a shorter exposure time and see if the maximum allowed frame rate increases. (You may need to compensate for a lower exposure time by using a brighter light source or increasing the opening of your lens aperture.)



An important thing to keep in mind is a common mistake new camera users frequently make when they are working with exposure time. They will often use a very long exposure time without realizing that this can severely limit the camera's maximum allowed frame rate. As an example, assume that your camera is set to use a 1 second exposure time. In this case, because each frame acquisition will take at least 1 second to be completed, the camera will only be able to acquire a maximum of one frame per second. Even if the camera's nominal maximum frame rate is, for example, 2 frames per second, it will only be able to acquire one frame per second because the exposure time is set much higher than normal.



## 9 Camera Features

### 9.1 Image Region of Interest

The Image Region of Interest (ROI) feature allows you to specify a portion of the sensor array. You can acquire only the frame data from the specified portion of the sensor array while preserving the same quality as you acquire a frame from the entire sensor array. With the ROI feature, you can achieve increased frame rates by decreasing the height of the ROI; however, decreasing the width of the ROI does not affect the frame rate. The ROI is referenced to the top left corner [origin (0, 0)] of the sensor array as follows.

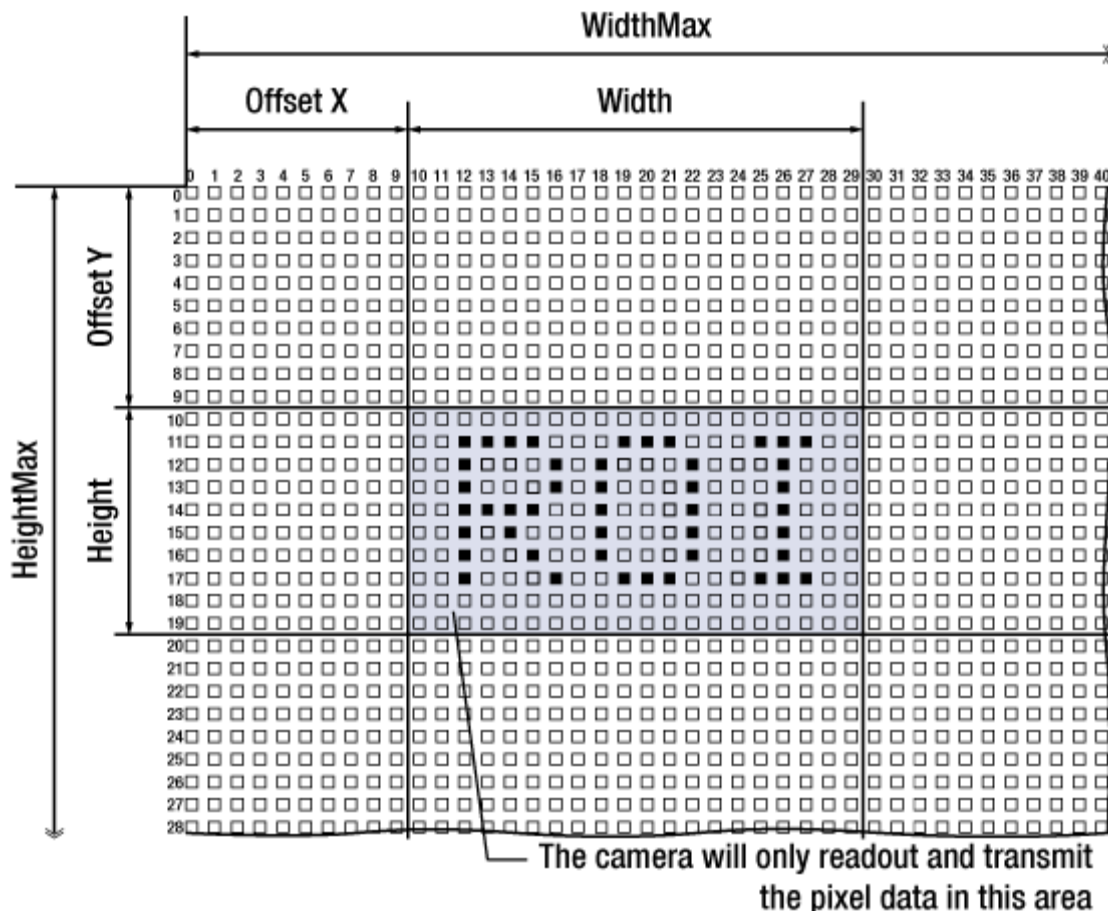

Figure 9.1 Image Region of Interest

The XML parameters related to ROI settings are as follows.

XML Parameters	Value	Description	
ImageFormatControl	SensorWidth <sup>a</sup>	-	Effective width of the sensor
	SensorHeight <sup>a</sup>	-	Effective height of the sensor
	WidthMax <sup>b</sup>	-	Maximum allowed width of the image with the current camera settings
	HeightMax <sup>b</sup>	-	Maximum allowed height of the image with the current camera settings
	Width <sup>c</sup>	-	Current width of the image
	Height <sup>c</sup>	-	Current height of the image
	OffsetX <sup>b, d</sup>	-	Horizontal offset from the origin to the Image ROI
	OffsetY <sup>b, d</sup>	-	Vertical offset from the origin to the Image ROI

The unit for all parameters in this table is pixel

a: Read only. User cannot change the value

b: Changes and updates according to the Binning settings

c: User configurable parameters for settings ROI

d: User configurable parameters for setting the origin of the ROI

**Table 9.1 XML parameters related to ROI**

You can change the size of ROI by setting the **Width** and **Height** parameters. And also, you can change the position of the ROI origin by setting the **Offset X** and **Offset Y** parameters.

Make sure that the **Width + Offset X** value is less than the **Width Max** value, and the **Height + Offset Y** value is less than the **Height Max** value. You must set the size of the ROI first, and then set the Offset values since the **Width** and **Height** parameters are set to its maximum value by default.

The **Width** parameter must be set to a multiple of 64 and its minimum value is 256. The **Width Max** and **Height Max** parameters will be changed and updated depending on the **Binning Horizontal** and **Binning Vertical** parameter settings respectively. And also, the **Width**, **Height**, **Offset X** and **Offset Y** parameters will be updated depending on the **Binning Horizontal** and **Binning Vertical** parameter settings respectively.

### Maximum Frame Rate of the VX-25MG Camera (Burst Mode)

The CMOS sensor installed in the VX-25MG camera can acquire up to 25 full frames per second. However, the nominal maximum frame rate of the VX-25MG camera is limited to 4.8 fps, since the speed of the sensor exceeds the bandwidth of the Gigabit Ethernet interface. If you acquire images at a rate faster than 4.7 fps, some images may be dropped. Operating the VX-25MG camera in Burst Mode allows you to acquire images beyond the interface speed limit. With 256 MB internal memory, the VX-25MG camera can buffer sequences of images into the internal memory. When you operate the camera with the sensor's maximum frame rate, you can acquire up to 8 full frames at 25 fps. This operation mode is called 'Burst Mode'.

With the VX-25MG camera, you can achieve increased frame rates by decreasing both the **Height** and **Width** parameters. The **Width** parameter must be set to a multiple of 64 and its minimum value is 256.

The frame rates in Burst Mode and the camera's nominal maximum frame rates depending on the ROI changes are as follows.

ROI Size (H × V)	VX-25MG
2560 × 2560	70.7 fps
5120 × 2560	50.9 fps
2560 × 5120	35.4 fps
5120 × 5120	25.5 fps

**Table 9.2 Frame Rates in Burst Mode by ROI Changes**

ROI Size (H × V)	VX-25MG
2560 × 2560	18.8 fps
5120 × 2560	9.4 fps
2560 × 5120	9.4 fps
5120 × 5120	4.7 fps

**Table 9.3 Maximum Frame Rates by ROI Changes**

## 9.2 Binning

Binning has the effects of increasing the level value and decreasing resolution by summing the values of the adjacent pixels and sending them as one pixel.

The XML parameters related to Binning are as follows.

XML Parameters		Value	Description
ImageFormatControl	BinningHorizontal	×1, ×2	Number of horizontal pixels to combine together
	BinningVertical	×1, ×2	Number of vertical pixels to combine together

**Table 9.4 XML Parameters related to Binning**

The VX-25MG camera provides two binning factors (×1 and ×2) that you can apply both horizontally and vertically. For example, if you set 2 × 2 binning as shown in the figure below, the camera's resolution is reduced to 1/2. With the 2 × 2 binning, four pixels are reported out of the camera as a single pixel as shown in the figure below. Using the binning feature reduces the resolution of the camera's output image in half, however, it results in double signal to noise ratio with the same brightness as an original image.

The **Width Max** and **Height Max** parameters, indicating the maximum allowed resolution of the image with the current camera settings, will be updated depending on the binning settings. And also, the **Width**, **Height**, **Offset X** and **Offset Y** parameters will be updated depending on the binning settings. You can verify the current resolution through the **Width** and **Height** parameters.

Width = 5120, Height = 5120

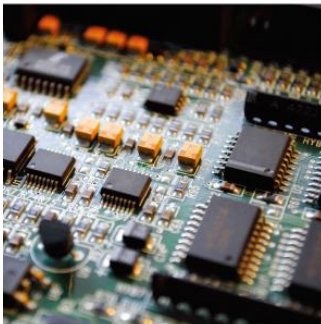

Binning Horizontal ×2



Binning Vertical ×2

Width = 2560, Height = 2560

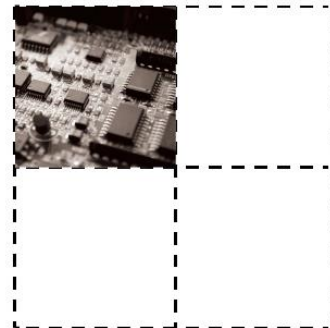

**Figure 9.2 Binning**

The VX-25MG camera supports  $\times 1$  and  $\times 2$  binning factors for both vertical and horizontal direction independently.

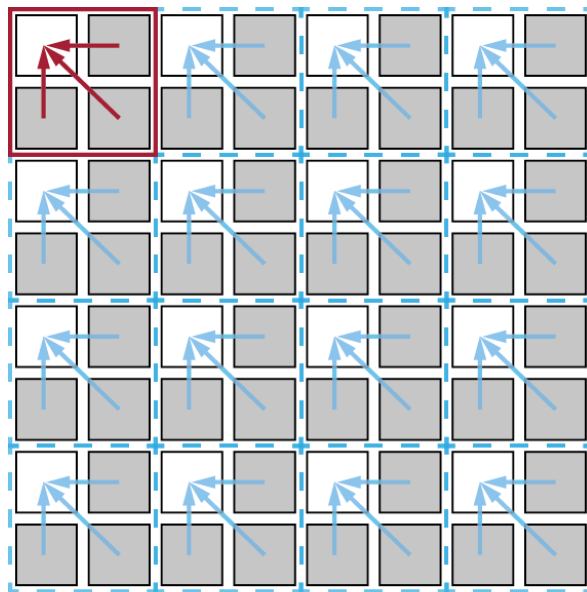

## **2 × 2 Binning**

**Figure 9.3** Binning factors

## 9.3 Exposure Control

Exposure is determined by the length of time (CMOS sensor is exposed to light) and the amount of light (light incident upon CMOS sensor). The exposure time is controlled in the VX camera by adjusting the **Exposure Time** parameter and the amount of light is controlled by the lens aperture and light condition. You can set the exposure manually or automatically by combining the related parameters.



The features related to aperture are only available when you equip a Canon-EF adapter with an EF lens.

### 9.3.1 Aperture Control

Aperture control is only working with an EF lens. To equip an EF lens, you must use a Canon-EF adapter (Figure 9.4). To use a Canon-EF adapter, you have to request an interface for Canon-EF adapter (Figure 9.5) option when you make an order. Canon-EF adapter provides RS-232 connection for power supply and serial communication. The control receptacle of the VX camera provides RS-232 interface to control the Canon-EF adapter (refer to [table 7.2](#)).



Figure 9.4 Canon-EF Adapter



Figure 9.5 Interface for Canon-EF Adapter



The procedures for power supply or communication interface connections may vary depending on the model. Please refer to the Canon-EF adapter user manual.

### 9.3.2 Exposure Auto, Gain Auto and Aperture Auto

The **Exposure Auto** feature automatically adjusts the **Exposure Time** parameter until the grey level for the pixels in the given ROI reaches an **Exposure Auto Target Level** value set by the user.

The **Exposure Auto** feature in the VX series uses iterative algorithm which repeatedly calculates the previous exposure values until it gets new exposure value. Note that the camera needs up to 30 frames to complete the Exposure Auto feature.



The **Exposure Auto** feature is not available if the **Exposure Mode** parameter is set to **Trigger Width**.

The **Exposure Auto**, **Gain Auto** and **Aperture Auto** features can be used at the same time and operated in the **Off**, **Once** and **Continuous** modes of operation. If you use three features at the same time, the camera will adjust the value of Aperture followed by Exposure and Digital Gain.

When the **Exposure Auto**, **Gain Auto** or **Aperture Auto** feature is set to **Once**, the parameter values are automatically adjusted until the related parameter value reaches the target value. After the automatic parameter value adjustment is complete, the feature will be set to **Off**. When the auto feature is set to **Continuous**, the camera adjusts Aperture, Exposure Time or Digital Gain parameter to reach the target value every time the lighting conditions change. You can set the **Exposure Auto Tolerance** parameter to adjust the sensitivity of the Exposure Auto feature.

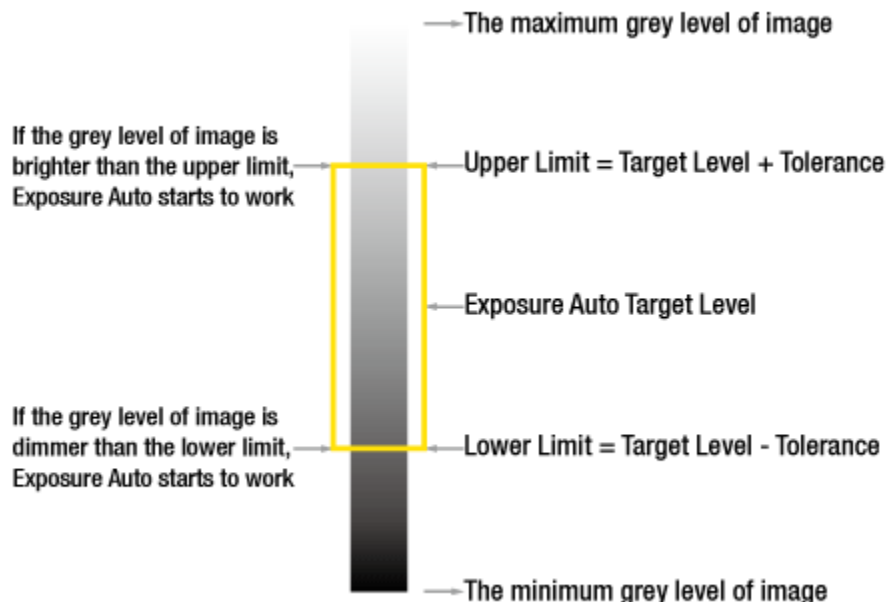

Figure 9.6 Exposure Auto Target Level and Exposure Auto Tolerance

Each auto feature has the following operating ranges depending on the object brightness level. You can set the operating range by adjusting the minimum and maximum value for each feature.

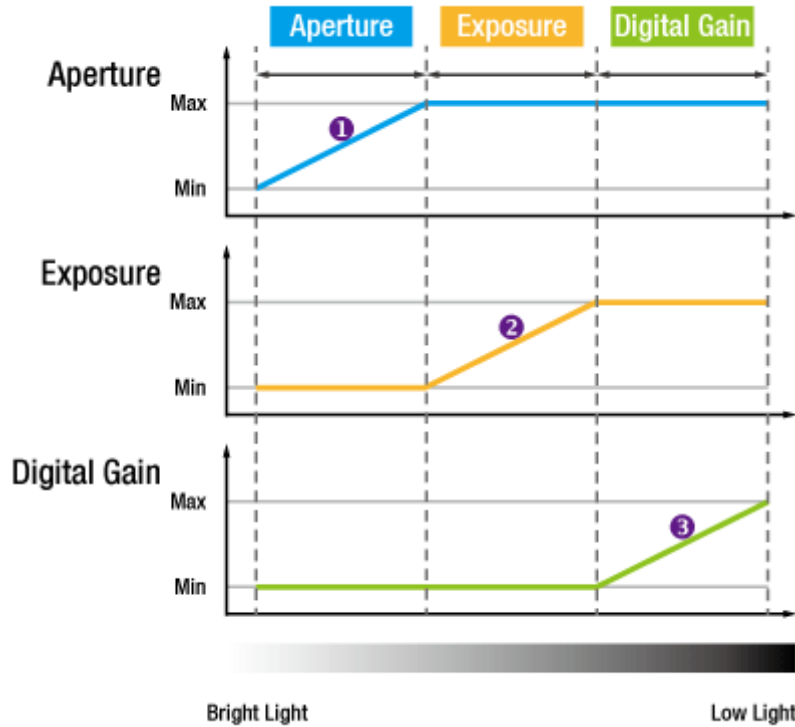

Figure 9.7 Image Level Adjustment

When the **Exposure Auto**, **Gain Auto** or **Aperture Auto** parameter is set to **Off**, the operating procedures are as follow.

Auto Features			Operating Procedures	Remarks
Aperture	Exposure	Gain		
On	On	Off	Aperture → Exposure	Manually adjustable the Gain
Off	On	On	Exposure → Gain	Manually adjustable the Aperture
On	Off	On	Aperture → Gain	Manually adjustable the Exposure
On	Off	Off	Aperture	Manually adjustable the Exposure/Gain
Off	On	Off	Exposure	Manually adjustable the Aperture/Gain
Off	Off	On	Gain	Manually adjustable the Aperture/Exposure

Table 9.5 Operating Procedures for Auto Features

When the Canon-EF adapter is not equipped on the VX-25MG camera, the parameters related to Aperture will be disabled and the operating procedures will be the same as when the **Aperture Auto** parameter had set to **Off**.



XML parameters related to AEC (Auto Exposure Control) are as follows.

XML Parameters		Value	Description
AcquisitionControl	ExposureAuto	Off	Exposure Auto Off
		Once	Target Level is adapted once and then Off
		Continuous	Target Level is constantly adapted
	ExposureAutoMin	1 $\mu$ s~	Lower limits of Exposure duration
	ExposureAutoMax	~60,000,000 $\mu$ s	Upper limits of Exposure duration
	ExposureAutoTargetLevel	20~235	Target average grey value (8bit <sup>†</sup> )
	ExposureAutoTolerance	6~62	Tolerance of the target average grey value - 8 bit (If the current grey level is out of the tolerance, AEC starts to work.)
AnalogControl	GainAuto	Off	Gain Auto Off
		Once	Gain is adjusted once and then Off
		Continuous	Gain is constantly adjusted
	GainAutoMin	×1~×4	Lower limits of Gain
	GainAutoMax		Upper limits of Gain
Canon- EFAdapterControl	ApertureAuto	Off	Aperture Auto Off
		Once	Aperture is adjusted once and then Off
		Continuous	Aperture is constantly adjusted
	ApertureAutoMin	0~	Lower limits of Aperture
	ApertureAutoMax	~21 <sup>†</sup>	Upper limits of Aperture
	ApertureClose	-	Set Aperture to its smallest opening
	ApertureOpen	-	Set Aperture to its widest opening
	ApertureAbsolute	-	Set Aperture to the absolute position by user setting
ApertureIncremental	-	Open (+) or close (-) Aperture with a specified value by user setting	

**Table 9.6 XML Parameters related to AEC on VX-25MG**



- You can set the Exposure Auto, Gain Auto and Aperture Auto feature in any order. However, we strongly recommend setting the one feature first while turning off the other features for the smooth operation.
- When you set the **Focus Auto** parameter to **Once** while using AEC (Auto Exposure Control), the camera will be paused. Then, the camera will perform the operation of the Auto Focus feature before performing AEC.
- † The maximum allowed **Exposure Auto Target Level** value may vary depending on the **Exposure Auto Tolerance** setting value.
  - 8 bit Pixel Format: Exposure Auto Target Level = (0+Tolerance) ~ (256 –Tolerance)
- ‡ The **Aperture Auto Max** value may vary depending on the lens model.

## 9.4 Pixel Format

The internal processing of image data is performed in 10 bits. Then, the camera can output the data in 8 bits. When the camera outputs the image data in 8 bits, the 2 least significant bits will be truncated accordingly.

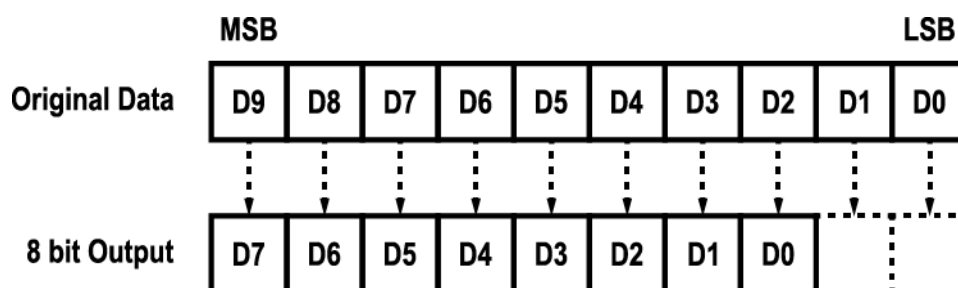

Figure 9.8 Pixel Format

The pixel data will be reordered in FPGA according to the **Pixel Format** setting value. Then, it will be stored in the frame buffer before output. XML parameter related to the Pixel Format is as follows.

XML Parameters		Description
ImageFormatControl	PixelFormat	Set the pixel format supported by the device

Table 9.7 XML Parameter related to Pixel Format



The VX-25MG camera only supports the 8 bit Pixel Format.

The supported pixel format for monochrome camera is as follows.

Mono Sensor
Mono 8

**Table 9.8 Pixel Data Format Value**

The structure for the supported pixel format is as follows.

### Mono 8

With the camera set to **Mono 8**, the pixel data output is 8 bit monochrome, unsigned char and unpacked type. This type is stored in a byte unit when 8 bit pixel data are stored in the frame buffer.

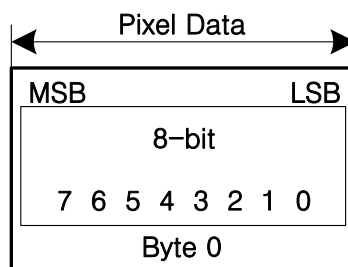

**Figure 9.9 Mono 8 Format**

## 9.5 Stream Hold

VX camera provides the **Stream Hold** feature for controlling the transmission of data.

Normally, the camera transmits frame data to the host computer immediately after completing the exposure. Enabling the **Stream Hold** feature delays the transmission of data, storing it in the camera's volatile memory until the **Stream Hold** feature is disabled.

This feature is especially useful to prevent flooding in Gigabit Ethernet network where multiple cameras are connected to a single host computer and capture a single event. Using the **Stream Hold** feature, each camera will hold the image data until the camera's **Stream Hold** feature is disabled. VX camera provides 256 MB on-board memory for the **Stream Hold** feature. The **Stream Hold** feature does not allow you to select which frame will be released to the host computer. When the **Stream Hold** feature is disabled, the stored frame data will be released to the host computer. For more information, refer to the application note about VX stream hold.

XML Parameters		Value	Description
TransportLayerControl	StreamHold	On	Delay the transmission of frame data and store them in the frame buffer.
		Off	Release the stored frame data to the host computer.
	FrameCapacity	-	<ul style="list-style-type: none"> <li>Display the maximum number of frames that you can store in the frame buffer</li> <li>The maximum number of frames will vary depending on the Image ROI and pixel format settings.</li> <li>If the camera's Stream Hold feature is set to On and the camera acquires the number of frames exceeding this value, the newly acquired frame will be ignored after saving the maximum number of frames.</li> </ul>

**Table 9.9 XML Parameters related to Stream Hold feature**

## 9.6 Inter-Packet Delay

VX camera provides the Inter-packet delay feature to set the delay in ticks between the packets transmitted by the camera.

### Packet Size

The **Gev SCPS Packet Size** parameter sets the size of the packets that the camera will use when it sends the data via the selected stream channel. This parameter should always be set to the maximum size that your network components (Ethernet Adapter) can handle.

### Setting the delay between packets

The **Gev SCPD** parameter sets the delay in ticks between the packets transmitted from the camera. Increasing the delay will decrease the camera's effective data transmission rate and will thus decrease the network bandwidth used by the camera.

In the VX camera, one tick is 8 ns. To check the tick frequency, read the **Gev Time stamp Tick Frequency** parameter value.

In case of multiple cameras or other devices working on the same physical network, it might be desirable to send the packets of a camera's streaming channel with a certain inter-packet delay in order to allow multiple cameras or devices to share a given network bandwidth.

XML Parameters		Value	Description
TransportLayerControl	GevSCPSPacketSize	576~16,000 Bytes	Set the packet size (The maximum value may vary depending on the Ethernet Adapter.).
	GevSCPD	0~4294967295	Set the delay between packets.

**Table 9.10 XML Parameters related to Inter-Packet Delay**

## 9.7 Data ROI

The Exposure Auto, Focus Auto and Balance White Auto features use the pixel data from a Data Region of Interest (ROI) to adjust the related parameters. XML parameters related to data ROI are as follows.

XML Parameters		Value	Description
DataRoiControl	RoiSelector	AE	Select a Data ROI used for Exposure Auto
		AF	Select a Data ROI used for Focus Auto
	RoiOffsetX	-	X coordinate of start point ROI
	RoiOffsetY	-	Y coordinate of start point ROI
	RoiWidth	-	Width of ROI
	RoiHeight	-	Height of ROI
	RoiDisplay	On	Display an inverted Data ROI region on the output image.
Off		Do not display a Data ROI region.	

**Table 9.11 XML Parameters related to Data ROI**

Only the pixel data from the area of overlap between the data ROI by your settings and the Image ROI will be effective if you use Image ROI and Data ROI at the same time. The effective ROI is determined as shown in the figure below.

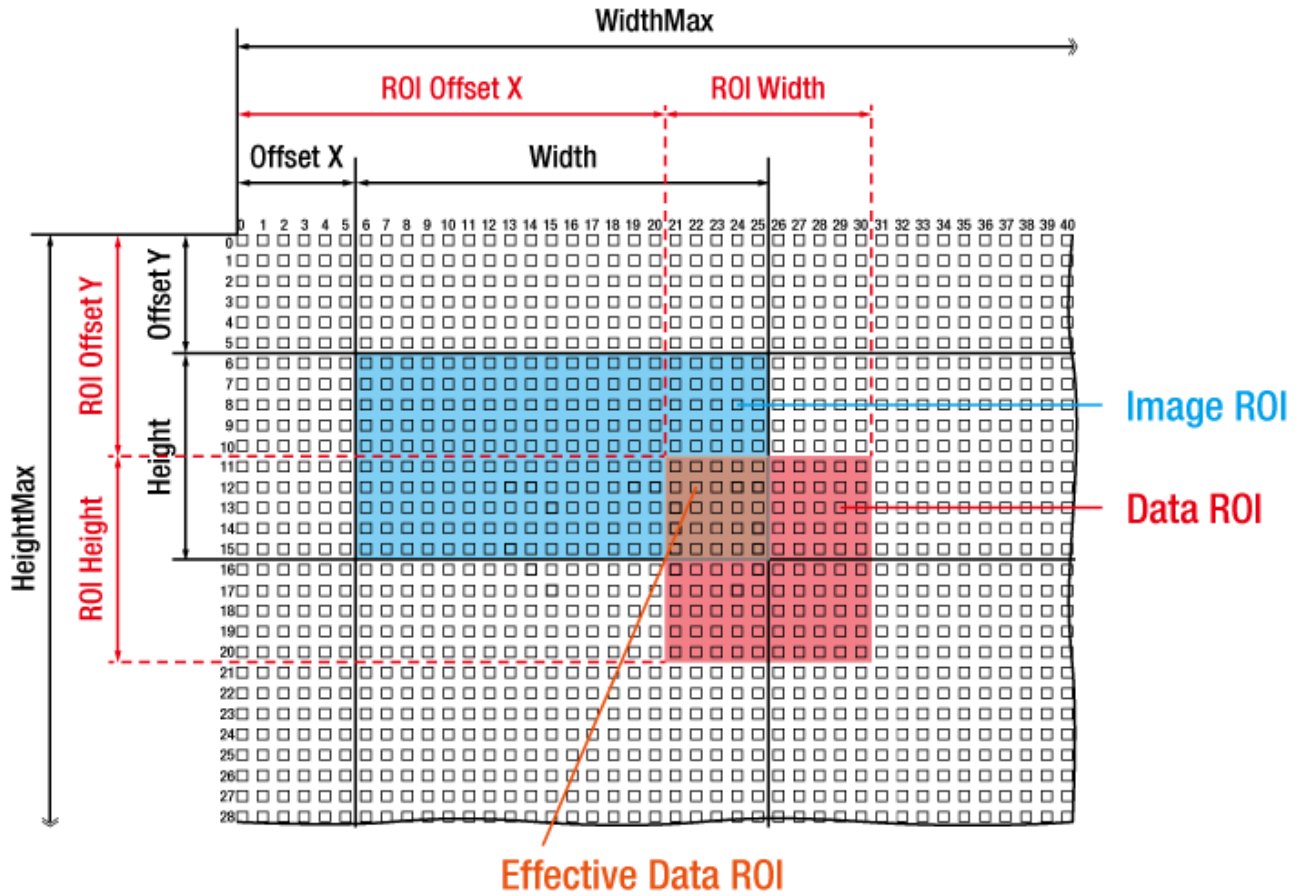

Figure 9.10 Effective Data ROI



## 9.8 Focus Auto

The **Focus Auto** feature is only available when you equip a Canon-EF adapter with an EF lens. VX camera uses Contrast Detection auto focus method which achieves focus data from the image. Auto focusing is a two-step process. First, focus data are extracted from the image in the Data Measure process. Then, the focus position will be located by using the focus data in the Peak Search process. It takes the maximum 3 seconds and requires the maximum 70 frames based on the maximum possible 25 megapixel image acquisition frame rate. If you use a lens which cannot support the maximum frame rate of the imaging sensor, it may take more time to complete the Focus Auto feature. When the **Focus Auto** feature is not completed successfully, the focus auto algorithm will be stopped after a period of time and then the **Focus Auto** mode will return to the **Off** state. If the exposure time is too short, the focus data may include noise data. To avoid incorrect operation caused by the noise, keep the proper exposure time. The **Focus Auto** parameter sets whether to use Auto Focus or Manual Focus.

XML parameters related to Focus Auto are as follows.

XML Parameters		Value	Description
Canon-EF Adapter Control	FocusZero	-	Move the focus position to its origin
	FocusInfinite	-	Move the focus position for infinity
	FocusAbsolute	-	Move the focus position to the absolute position by user setting. The available position may vary depending on the lens model.
	FocusIncremental	-	Move the focus position with specified value by user setting
	FocusAuto	Off	Adjust the focus position manually
		Once	Move the focus position once and then Off
	FocusPosition	-	Display the current focus position

**Table 9.12 XML Parameters related to Focus Auto**



- Center the data ROI as much as possible when you use the **Focus Auto** feature. If the data ROI is significantly displaced from the sensor's center, the **Focus Auto** feature may not work correctly because the position of an object in the ROI can be changed during focusing.
- If you use a lens equipped with a DC motor, the focusing position may be incorrect.

## 9.9 Gain and Black Level

You can set the digital gain factor to adjust the gain. The black level is adjusted by removing the optical black offset from the CMOS sensor so that the effect of dark current will be minimized.

### 9.9.1 Digital Domain

Digital gain is adjustable from 1 to  $\times 4$  with almost 1/128 step. If the **Gain Auto** parameter is set to **Once** or **Continuous**, the digital gain value will be automatically adjusted according to the **Exposure Auto Target Level** parameter settings. XML parameters related to Gain and Black Level are as follows.

XML Parameters		Value	Description
AnalogControl	GainSelector	DigitalAll	Apply gain to all digital channels
	Gain	-	Set an absolute physical gain value. • $\times 1.0 \sim \times 4.0$
	GainAuto	Off	Gain Auto Off
		Once	Gain value is adjusted once and then Off
		Continuous	Gain value is constantly adjusted
	BlackLevelSelector	DigitalAll	Apply black level to all digital channels
BlackLevel	0~16	Set an absolute physical black level value. (0 ~ 16 LSB @ 8bit)	

**Table 9.13 XML Parameters related to Gain and Black Level**

## 9.10 Defective Pixel Correction

The CMOS may have Defect Pixels which cannot properly react to the light. Correction is required since it may deteriorate the quality of output image. Defect Pixel information of CMOS used for each camera is entered into the camera during the manufacturing process in the factory. If you want to add Defect Pixel information, it is required to enter coordinate of new Defect Pixel into the camera.

### 9.10.1 Correction Method

A correction value for a defect pixel is calculated based on the valid pixel value adjacent in the same line.

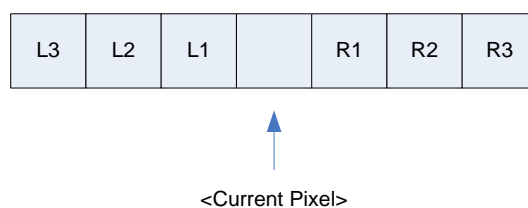

**Figure 9.11 Location of Defect Pixel to be corrected**

If the current pixel is a defect pixel as shown in the figure above, the correction value for this pixel is obtained as shown in the following table depending on whether surrounding pixels are defect pixels or not.

Adjacent Defect Pixel(s)	Correction value of Current Pixel
None	$(L1 + R1) / 2$
L1	R1
R1	L1
L1, R1	$(L2 + R2) / 2$
L1, R1, R2	L2
L2, L1, R1	R2
L2, L1, R1, R2	$(L3 + R3) / 2$
L2, L1, R1, R2, R3	L3
L3, L2, L1, R1, R2	R3

**Table 9.14 Calculation of Defect Pixel Correction Value**

## 9.10.2 Correction Method in Binning Mode

The **Defective Pixel Correction** feature is also available with the 2×2 binning enabled. The correction value will be averaged based on four neighboring pixels when the 2×2 binning is enabled.

XML parameter related to Defective Pixel Correction is as follows.

XML Parameters		Value	Description
ImageFormatControl	DefectivePixelCorrection	On	Apply a downloaded defective pixel map to the camera
		Off	Disable the application of the defective pixel map

**Table 9.15 XML Parameter related to Defective Pixel Correction**



To apply the **Defective Pixel Correction** feature, you must download a Defective Pixel Map to the camera. For more information about how to download a Defective Pixel Map to the camera, refer to [Appendix A](#).

### 9.11 Flat Field Correction

The Flat Field Correction feature improves the image uniformity when you acquire a non-uniformity image due to external conditions.

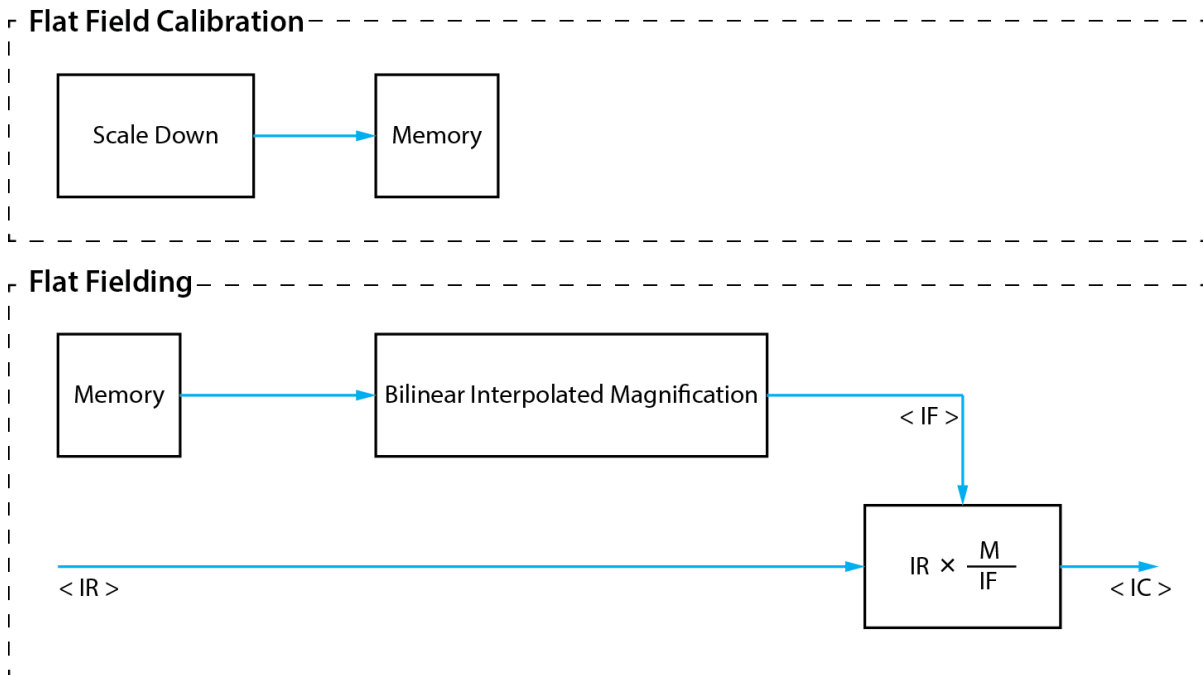

Figure 9.12 Generation and Application of Flat Field Data

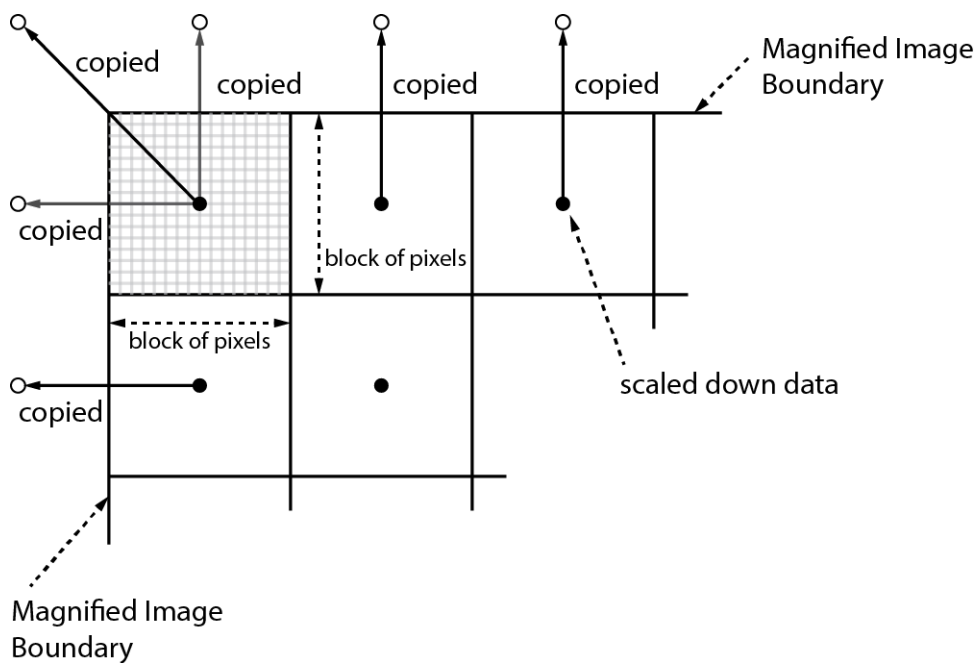

Figure 9.13 Bilinear Interpolated Magnification

The Flat Field Correction feature of the VX-25MG camera can be summarized by the following equation:

$$IC = IR / IF$$
 where,  
 IC: Level value of corrected image;  
 IR: Level value of original image;  
 IF: Level value of Flat Field data.

In actual use conditions, generate a Flat Field data (IF) and perform the Flat Field Correction feature according to the following procedures.

1. Execute the **Ffc Generate** parameter.  
After executing the **Ffc Generate** parameter, you must acquire one image to generate the scaled down Flat Field data.
2. Execute the **Ffc Save** parameter to save the generated Flat Field data in the non-volatile memory.  
When the Flat Field data are applied for correction, the Flat Field data which were scaled down will be enlarged via Bilinear Interpolation as shown in the Figure 9.13.
3. Set the **Ffc Mode** parameter to **On** to apply the Flat Field data to the camera.



- It is recommended that you enable the **Defective Pixel Correction** feature before executing the **Ffc Generate** parameter.
- Before executing the **Ffc Generate** parameter, you must set the camera as follows:
  - OffsetX, Y: 0
  - Width, Height: Maximum values
  - Binning: ×1
- After executing an **Acquisition Start** command, you need to operate the camera with free-run mode or apply a trigger signal to acquire an image.

XML parameters related to Flat Field Correction are as follows.

XML Parameters		Value	Description
FlatFieldCorrection	FfcMode	Off	Flat Field Correction Off
		On <sup>†</sup>	Enable the Flat Field Correction feature
	FfcGenerate	-	Generate the Flat Field data
	FfcSave	-	Save the generated Flat Field data in the non-volatile memory. The generated data by executing the <b>FfcGenerate</b> parameter are saved in the volatile memory and the data are lost if the camera is reset or if power is turned off. To use the data after the camera is powered on or reset, save them in the non-volatile memory.
	FfcLoad	-	Load the Flat Field data from the non-volatile memory into volatile memory

†: If the current setting values for the Binning Horizontal and Binning Vertical parameters are different from the setting values at the time when you generate the Flat Field data, the Flat Field Correction feature is not available even if you set the **Ffc Mode** parameter to **On**.

**Table 9.16 XML Parameters related to Flat Field Correction**

## 9.12 Temperature Monitor

A sensor chip is embedded in the camera to monitor the internal temperature.

XML parameter related to Device Temperature is as follows.

XML Parameters		Description
DeviceControl	DeviceTemperature	Display device temperature in Celsius

**Table 9.17 XML Parameter related to Device Temperature**

## 9.13 Status LED

A green LED is installed on the back panel of the camera to inform the operation status of the camera. LED status and corresponding camera status are as follows:

- Steady Red: The camera is not initialized.
- Slow Flashing Red: Gigabit Ethernet connection is not configured.
- Fast Flashing Orange: The camera is checking IP address.
- Steady Green: An IP address is assigned
- Fast Flashing Green: The camera is transmitting image data.



## 9.14 Test Image

To check whether the camera operates normally or not, it can be set to output test images generated in the camera, instead of the image data from the CMOS sensor. Three types of test images are available; image with different value in horizontal direction (Grey Horizontal Ramp), image with different value in diagonal direction (Grey Diagonal Ramp), and moving image with different value in diagonal direction (Grey Diagonal Ramp Moving).

XML parameters related to Test Image are as follows.

XML Parameters		Value	Description
ImageFormatControl	TestImageSelector	Off	Test Image Off
		GreyHorizontalRamp	Set to Grey Horizontal Ramp
		GreyDiagonalRamp	Set to Grey Diagonal Ramp
		GreyDiagonalRampMoving	Set to Grey Diagonal Ramp Moving

**Table 9.18 XML Parameter related to Test Image**

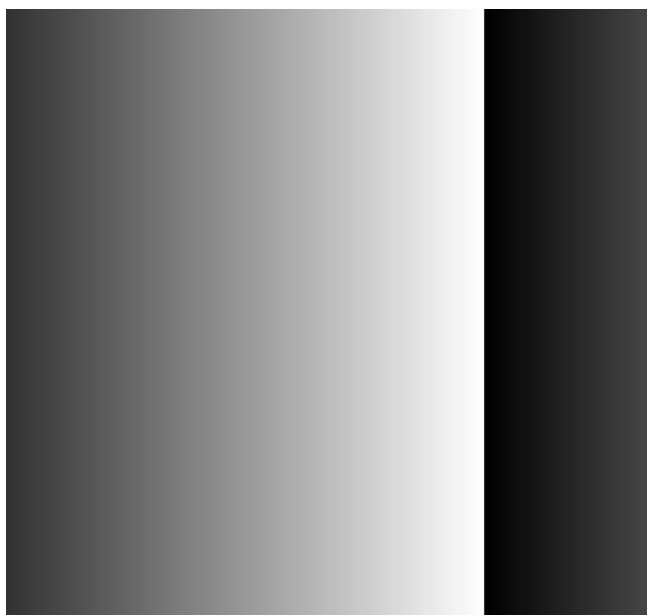

**Figure 9.14 Grey Horizontal Ramp**

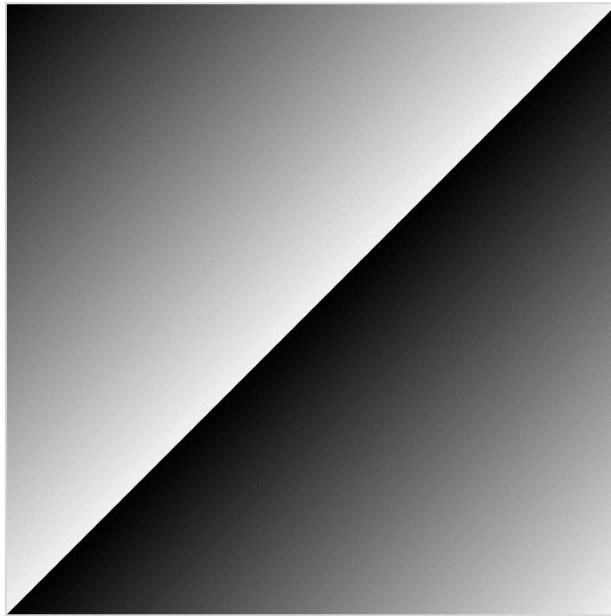

**Figure 9.15 Grey Diagonal Ramp**

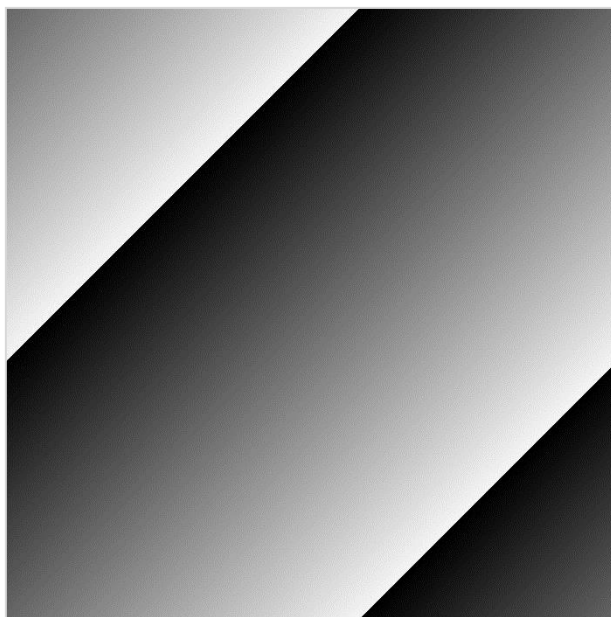

**Figure 9.16 Grey Diagonal Ramp Moving**



The test image may look different because the region of the test image may vary depending on the camera's resolution.

## 9.15 Digital IO Control

The pin number 3 of the control receptacle is designated as programmable output and can be operated in various modes.

XML parameters related to Digital IO Control are as follows.

XML Parameters		Value	Description
DigitalIO Control	LineInverter	On	Invert the output signal of the line
		Off	Do not invert the output signal of the line
	LineSource	Off	Disable the line output
		ExposureActive	Output pulse signals indicating the current exposure time
		FrameActive	Output pulse signals indicating a frame readout time
		StrobeOut	Output Exposure Active signals with Strobe Out Delay
		PulseGenerator	Output user defined pulse signals
		UserOutput	Output User Output signal set by User Output Value
		UserOutputValue	On
	Off		Set the bit state of the line to Low
	PulsePeriod	1~60,000,000	Set a pulse period in microseconds when the Line Source is set to Pulse Generator
	PulseWidth	0~60,000,000	Set a pulse width in microseconds when the Line Source is set to Pulse Generator
	StrobeOutDelay	0~65535	Set a delay in microseconds when the Line Source is set to Strobe Out

**Table 9.19 Digital IO Control**

The camera can provide a **Strobe Out** output signal. The signal goes high when the exposure time for each frame acquisition begins and goes low when the exposure time ends as shown in Figure 9.17. This signal can be used as a flash trigger and is also useful when you are operating a system where either the camera or the object being imaged is movable. Typically, you do not want the camera to move during exposure. You can monitor the **Strobe Out** signal to know when exposure is taking place and thus know when to avoid moving the camera.

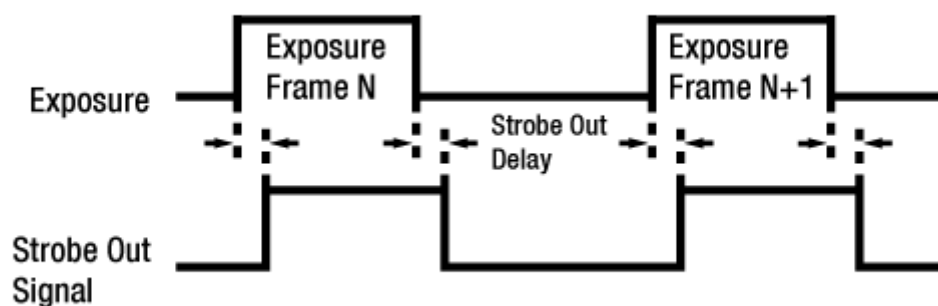

Figure 9.17 Strobe Out Signal (not drawn to scale)

### 9.15.1 Debounce

The Debounce feature of the VX-25MG camera allows to supply only valid signals to the camera by discriminating between valid and invalid input signals. The **Debounce Time** parameter specifies the minimum time that an input signal must remain High or Low in order to be considered as a valid input signal. When you use the Debounce feature, be aware that there is a delay between the point where the valid input signal arrives and the point where the signal becomes effective. The duration of the delay is determined by the Debounce Time parameter setting value. When you set the **Debounce Time** parameter, High and Low signals shorter than the setting value are considered invalid and ignored as shown in the figure below.

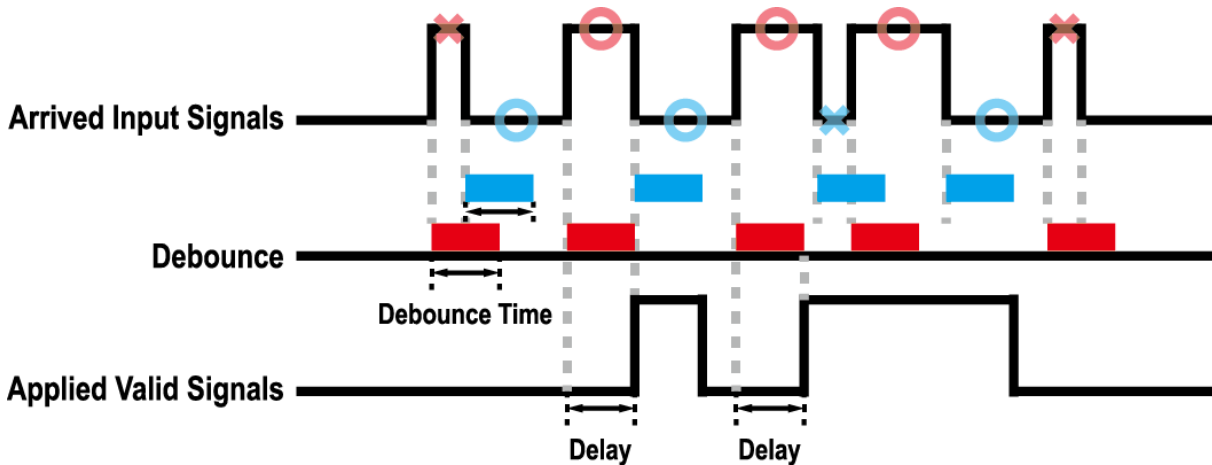

Figure 9.18 Debounce

XML parameter related to Debounce is as follows.

XML Parameters		Value	Description
DigitalIOControl	DebounceTime	0 ~ 1,000,000 $\mu$ s	Set a Debounce Time value in 20 nanoseconds (Default: 0.5 $\mu$ s)

Table 9.20 XML Parameter related to Debounce Time

### 9.16 Device User ID

You can input user defined information up to 16 bytes. XML parameter related to Device User ID is as follow.

XML Parameters		Description
DeviceControl	DeviceUserID	Input user defined information (16 bytes)

Table 9.21 XML Parameter related to Device User ID

## 9.17 Device Reset

Reset the camera physically to power off and on. You must connect to the network because the camera will be released from the network after reset. XML parameter related to Device Reset is as follows.

XML Parameters		Description
DeviceControl	DeviceReset	Reset the camera physically

Table 9.22 XML Parameter related to Device Reset

## 9.18 User Set Control

You can save the current camera settings to the camera's internal ROM. You can also load the camera settings from the camera's internal ROM. The camera provides two setups to save and three setups to load settings.

XML parameters related to User Set Control are as follows.

XML Parameters		Value	Description
UserSetControl	UserSetSelector	Default	Select the Factory Default settings
		UserSet1	Select the User Set1 settings
		UserSet2	Select the User Set2 settings
	UserSetLoad	-	Load the User Set specified by User Set Selector to the camera
	UserSetSave	-	Save the current settings to the User Set specified by User Set Selector Default is allowed to load only.
	UserSetDefaultSelector	Default	Apply the Factory Default settings when reset
		UserSet1	Apply the User Set1 settings when reset
		UserSet2	Apply the User Set1 settings when reset

Table 9.23 XML Parameters related to User Set Control

## 9.19 Field Upgrade

The camera provides a feature to upgrade Firmware and FPGA logic through Gigabit Ethernet interface rather than disassemble the camera in the field. Refer to [Appendix B](#) for more details on how to upgrade.

## 10 Troubleshooting

When you have a problem with a Vieworks camera, please check the followings.

- If no image is displayed on your computer,
  - Ensure that all the cable connections are secure.
  - Ensure that the power supply is properly connected.
  - Ensure that trigger signal is applied correctly when you set the Trigger Mode parameter to On.
  
- If images are not clear,
  - Ensure the camera lens or glass is clean.
  - Check the lens aperture is adjusted properly.
  
- If images are dark,
  - Ensure your camera lens is not blocked.
  - Check the exposure time is set properly.
  - Check the aperture is opened properly.
  - Check the Gain value is not set too small.
  
- If you identify abnormal operation or overheating sign,
  - Ensure that power supply is properly connected.
  - Stop using the camera when you notice smoke or abnormal overheating.
  
- If you have a problem using the Trigger Mode,
  - Ensure that the Software trigger related parameters are configured correctly.
  - Ensure that the cable connections are secure when you set the Trigger Source parameter to External.
  
- If there is a communication failure between the camera and computer,
  - Ensure the Gigabit Ethernet cable is connected properly.
  - Ensure that you have configured a Gigabit Ethernet card in your computer correctly and the camera is connected properly to the Gigabit Ethernet card.

## Appendix A Defective Pixel Map Download

1. Create the Defective Pixel Map data in Microsoft Excel format as shown in the left picture below and save as a CSV file (\*.csv). The picture in the right shows the created Excel file opened in Notepad. The following rules need to be applied when creating the file.
  - Lines beginning with ':' or '--' are treated as notes.
  - You must enter the horizontal value first and then the vertical value for coordinate of each defect pixel.
  - Coordinate values for each pixel can be placed in any order.

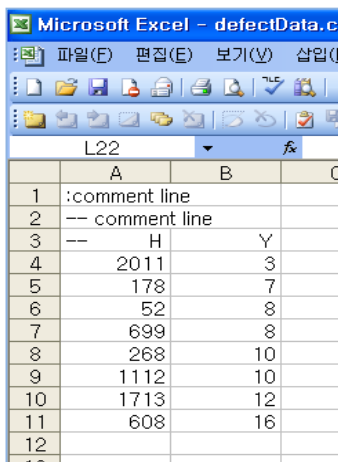

	A	B	C
1	:comment line		
2	-- comment line		
3	-- H	Y	
4	2011	3	
5	178	7	
6	52	8	
7	699	8	
8	268	10	
9	1112	10	
10	1713	12	
11	608	16	
12			

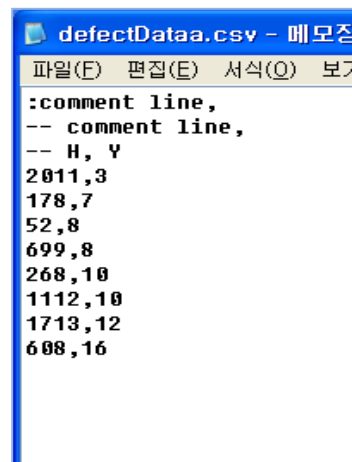

```

:comment line,
-- comment line,
-- H, Y
2011,3
178,7
52,8
699,8
268,10
1112,10
1713,12
608,16
  
```

2. Run Vieworks Imaging Solution 7.X and click the **Configure** button to display the window as shown below. Select the **Defect** tab, click the File Path button, search and select the defective pixel map file (\*.csv), and then click the **Download** button.

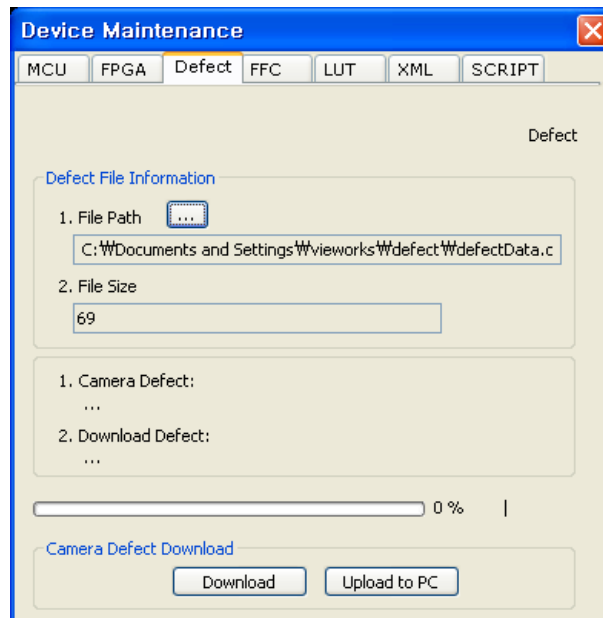



- Once the download is complete, the saving process will begin. During the saving process, make sure not to disconnect the power cord.

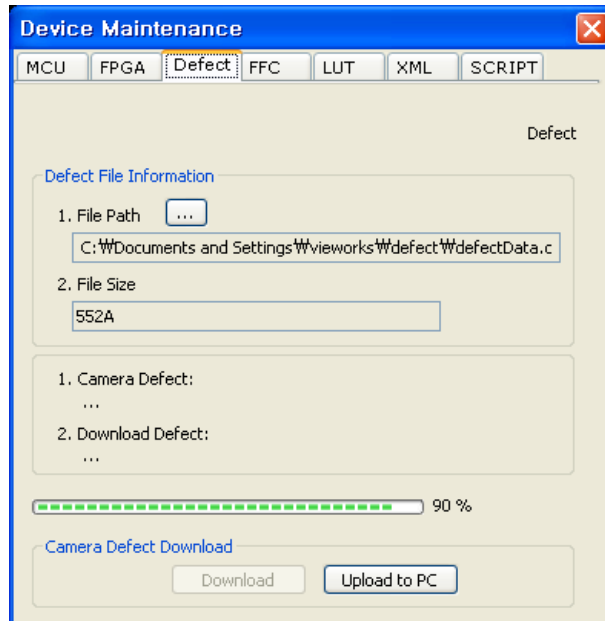

- After completing the download, click the **OK** button to close the confirmation.

## Appendix B Field Upgrade

### B.1 MCU

1. Run Vieworks Imaging Solution 7.X and click the **Configure** button to display the window as shown below.
2. Select the **MCU** tab, click the File Path button, search and select the MCU upgrade file (\*.mcu), and then click the **Download** button.

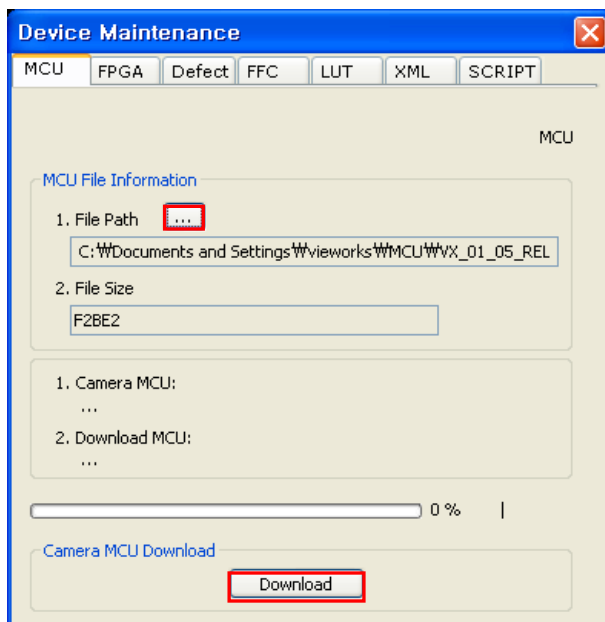

3. MCU upgrade file download starts and the downloading status is displayed at the bottom of the window.

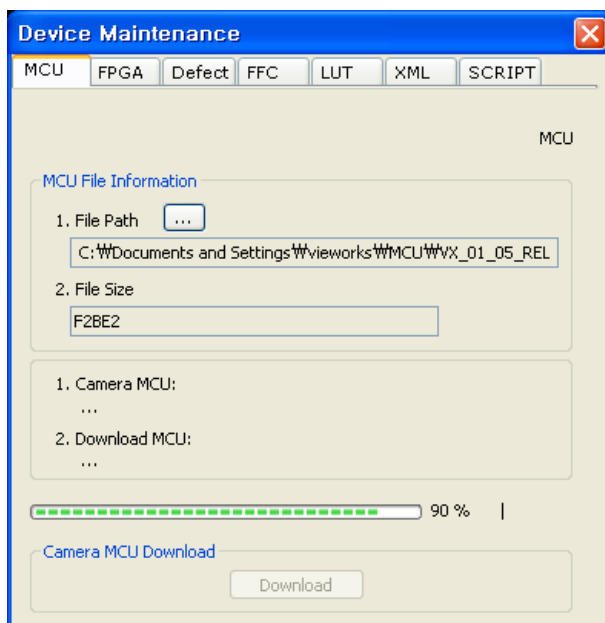

- Once all the processes have been completed, turn the power off and turn it back on again. Check the DeviceVersion parameter value to confirm the version. Or, check under the My Computer to verify the upgraded version.

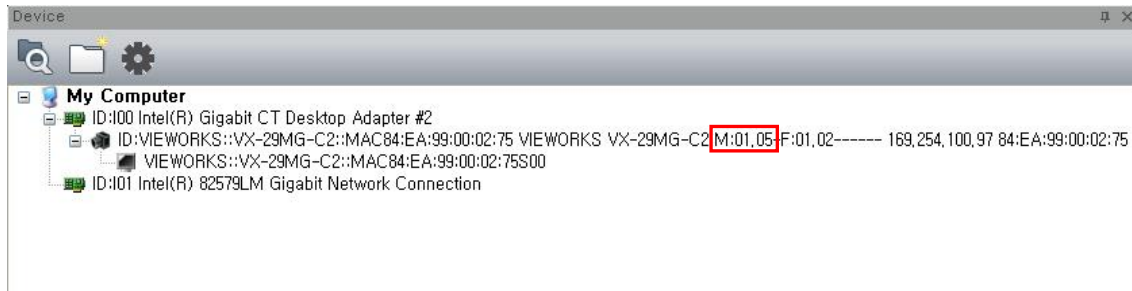

## B.2 FPGA

1. Run Vieworks Imaging Solution 7.X and click the **Configure** button to display the window as shown below.
2. Select the **FPGA** tab, click the File Path button, search and select the FPGA upgrade file (\*.fpga), and then click the **Download** button.

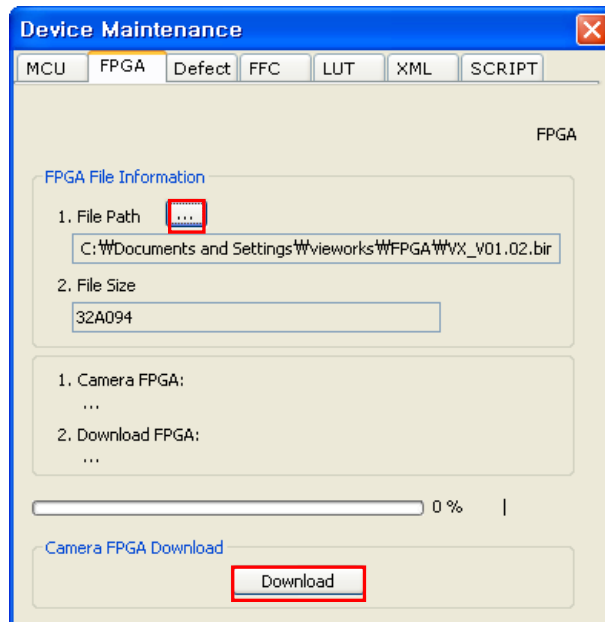

3. The subsequent processes are identical to those of MCU upgrade.

## B.3 XML

1. Run Vieworks Imaging Solution 7.X and click the **Configure** button to display the window as shown below.
2. Select the **XML** tab, click the File Path button, search and select the XML upgrade file (\*.vxf), and then click the Download button.

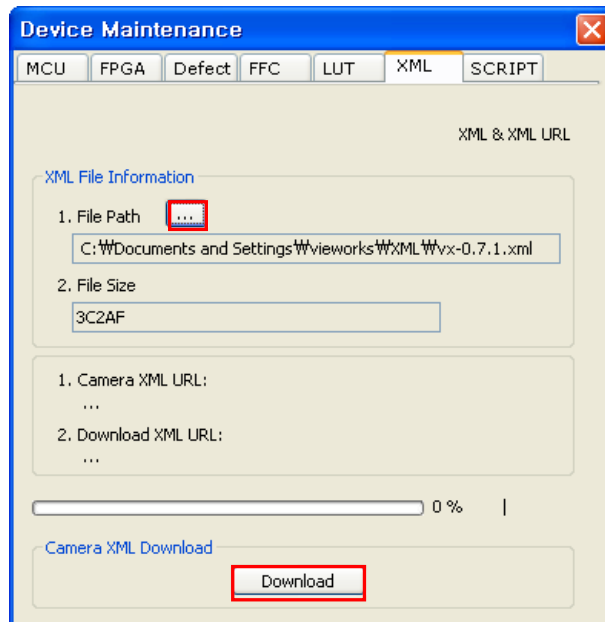

3. The subsequent processes are identical to those of MCU upgrade.

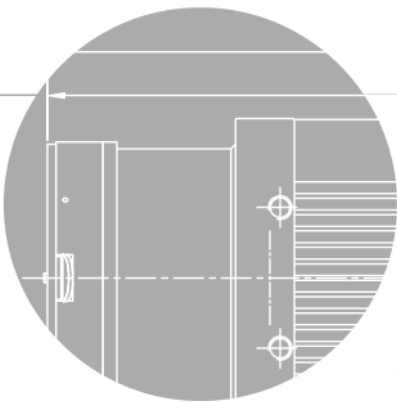
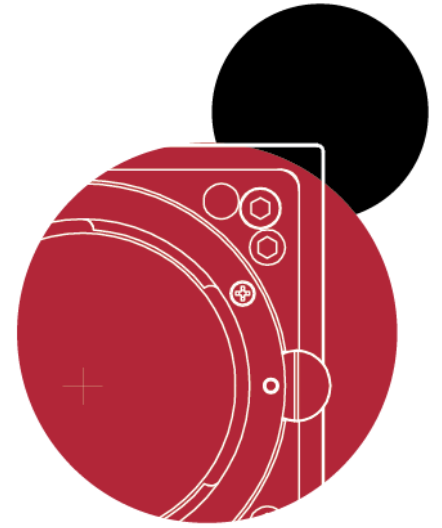
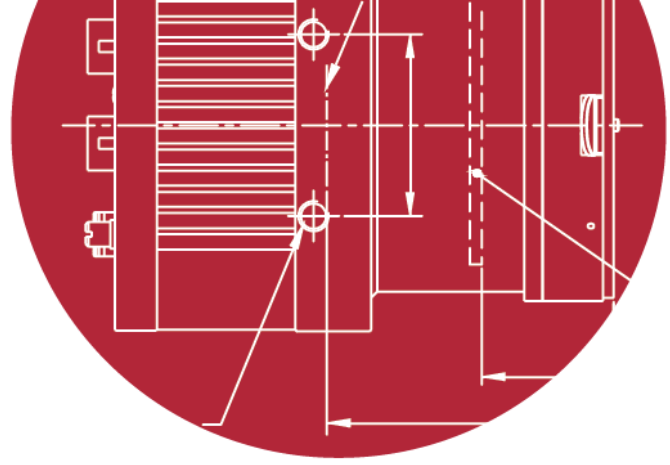

**Vieworks Co., Ltd.**

41-3, Burim-ro, 170beon-gil,  
Dongan-gu, Anyang-si, Gyeonggi-do  
431-060 Republic of Korea

Tel: +82-70-7011-6161

Fax: +82-31-386-8631

<http://www.vieworks.com>

[vieworks@vieworks.com](mailto:vieworks@vieworks.com)