

VP series

User Manual

English

VP-103MX2-M24I
VP-103MX2-C24I

CoaPress[®]

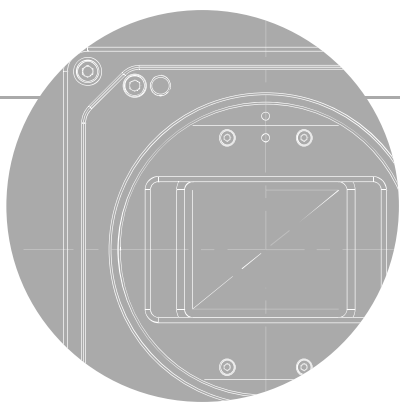

VIEWWORKS

Preface

No part of this manual may either be copied, reproduced, translated, or published in any form or by any means (electronic, mechanical, photocopying, or otherwise) without the express written permission of Vieworks, Co., Ltd. (hereinafter 'Vieworks').

This manual may include the website links to companies other than Vieworks. Vieworks is not responsible for any of these links. The copyrights of the materials mentioned herein are owned by each respective author.

Although Vieworks made every effort to ensure the accuracy of this document, it assumes no responsibility for errors or omissions that may appear herein. The figures in this manual may differ depending on the version of the product or operating system, or the way how it runs. Information in this manual is subject to change without notice.

Before Using This Product

Thank you for choosing VP-103MX2-M/C24I™.

- Make sure to read this manual before using the product.
- Make sure to check whatever a professional engineer has finished installation and configuration.
- Make sure to keep this manual at hand as a reference while using the product.
- This manual assumes that you have expertise in how to use an industrial camera.

The Series

This manual is intended for users of the following products:

- VP-103MX2-M/C24I

About This Manual

This manual is intended for VP-103MX2-M/C24I™ camera users. It is recommended to refer to the Frame Grabber's User Manual of yours, with this manual.

Convention in This Manual

For better understanding, the following conventions are used throughout the manual.

Names and Fonts

The names and fonts of user interfaces are used as follows:

- The menu and icon names in this manual are used as displayed in the product.
- The menu and icon names are marked in this font.
- Button or keyboard key names are marked in this font.

Warning, Caution, and Note

This manual shows warnings, cautions, and notes with the following figures:

**Warning!**

This indicates that you need to follow this message for your safety and to prevent the product from damage.

**Caution!**

This indicates that you need to follow this message to prevent data from being lost or corrupted.

**Note:**

This indicates that this message provides additional information.

Definition of Terms

For clarity, this manual defines some terms as follows:

Term	Definition
Preface	The introductory part preceding the Table of Contents in this manual
Vieworks Imaging Solution	Indicates the control software provided with the product together by Vieworks
VIS	Vieworks Imaging Solution

Revision History

This document has the revision history as follows:

Version	Date	Description
1.0	2022-04-15	Initial Release
	2022-12-23	Deleted the items related to PoCXP

Contents

Chapter 1. Precautions	15
Chapter 2. Warranty	17
Chapter 3. Compliance & Certifications	18
3.1 FCC Compliance.....	18
3.2 CE : DoC.....	18
3.3 KC	18
Chapter 4. Package Components.....	19
Chapter 5. Product Specifications.....	20
5.1 Overview.....	20
5.2 Specifications	21
5.3 Camera Block Diagram	22
5.4 Spectral Response	23
5.5 Mechanical Specification	24
5.5.1 Camera Mounting and Heat Dissipation	25
Chapter 6. Connecting the Camera.....	26
6.1 Precaution to Center the Image Sensor	26
6.2 Precaution about Blurring Compared to the Center.....	26
6.3 Installing Vieworks Imaging Solution	26
Chapter 7. Camera Interface.....	27
7.1 General Description.....	27
7.2 CoaXPress Connector	28
7.2.1 Micro-BNC Connector.....	28
7.3 Power Input Receptacle	29
7.4 Control Receptacle.....	30
7.5 Trigger Input Circuit.....	31
7.6 Strobe Output Circuit	31
Chapter 8. Acquisition Control.....	32
8.1 Overview.....	32

8.2	Acquisition Start/Stop Commands and Acquisition Mode.....	33
8.2.1	Acquisition Start/Stop Commands.....	33
8.2.2	Acquisition Mode.....	33
8.2.3	Exposure Start Trigger	34
8.2.4	Applying Trigger Signals	35
8.2.5	Exposure Time Control.....	36
8.3	Exposure Start Trigger	37
8.3.1	Trigger Mode	37
8.3.2	Using a Software Trigger Signal.....	40
8.3.3	Using a CoaXPress Trigger Signal.....	41
8.3.4	Using an External Trigger Signal	42
8.3.5	Exposure Mode	44
8.4	Setting the Exposure Time	46
8.5	Overlapping Exposure with Sensor Readout	47
8.6	Global Shutter	49
8.7	Maximum Allowed Frame Rate.....	50
8.7.1	Increasing the Maximum Allowed Frame Rate	51
Chapter 9. Camera Features.....		52
9.1	Sequence of Signal Processing	52
9.2	Region of Interest	53
9.3	Multi-ROI.....	57
9.4	Binning.....	60
9.5	CXP Link Configuration.....	62
9.6	Pixel Format.....	63
9.7	Data ROI (Color Only)	64
9.8	White Balance (Color Only).....	65
9.8.1	Balance White Auto	65
9.9	Gain	66
9.10	Black Level and Optical Black Correction	66

9.11	Defective Pixel Correction	70
9.11.1	Correction Method.....	70
9.12	Dark Signal Non-uniformity Correction	71
9.12.1	Generating and Saving User DSNU Correction Values	72
9.13	Photo Response Non-uniformity Correction	73
9.13.1	Generating and Saving User PRNU Correction Values	74
9.14	Flat Field Correction.....	75
9.14.1	Flat Field Data Selector	78
9.15	Timestamp.....	79
9.16	Event Control.....	80
9.17	Digital I/O Control	81
9.18	Debounce.....	83
9.19	Timer Control	84
9.20	Cooling Control.....	85
9.21	Temperature Monitor.....	86
9.22	Status LED	86
9.23	Test Pattern	87
9.24	Reverse X.....	90
9.25	Reverse Y.....	91
9.26	Device Link Throughput Limit.....	92
9.27	Device User ID	92
9.28	Device Reset	92
9.29	Field Upgrade.....	93
9.30	User Set Control.....	93
9.31	Sequencer Control	95
Chapter 10. Troubleshooting.....		98
Appendix A. Defective Pixel Map Download		99
Appendix B. Field Upgrade.....		100
Appendix C. Index		101

Tables

Table 5-1	Specifications VP-103MX2-M/C24I	21
Table 7-1	Channel Assignments for Micro-BNC Connector	28
Table 7-2	Pin Configurations for Power Input Receptacle	29
Table 7-3	Pin Configurations for Control Receptacle	30
Table 8-1	Minimum and Maximum Exposure Time Setting	46
Table 9-1	XML Parameters related to ROI	54
Table 9-2	Minimum ROI Width and Height Settings.....	54
Table 9-3	Maximum Frame Rates by VP-103MX2-M/C24I ROI Changes_CXP-6.....	55
Table 9-4	Maximum Frame Rates by VP-103MX2-M/C24I ROI Changes_CXP-10.....	55
Table 9-5	Maximum Frame Rates by VP-103MX2-M/C24I ROI Changes_CXP-12.....	56
Table 9-6	XML parameters related to Multi-ROI.....	57
Table 9-7	XML Parameters related to Binning	60
Table 9-8	XML Parameters related to CXP Link Configuration.....	62
Table 9-9	XML Parameter related to Pixel Format	63
Table 9-10	Pixel Format Values	63
Table 9-11	XML Parameters related to Data ROI.....	64
Table 9-12	XML Parameters related to White Balance.....	65
Table 9-13	XML Parameter related to Balance White Auto.....	65
Table 9-14	XML Parameters related to Gain	66
Table 9-15	XML Parameters related to Black Level.....	69
Table 9-16	Calculation of Defect Pixel Correction Value	70
Table 9-17	XML Parameters related to DSNU	71
Table 9-18	XML Parameters related to PRNU	73
Table 9-19	XML Parameters related to Flat Field Correction.....	77

Table 9-20	XML Parameters related to Timestamp.....	79
Table 9-21	XML Parameters related to Event Control.....	80
Table 9-22	XML Parameters related to Digital I/O Control	81
Table 9-23	XML Parameter related to Debounce Time	83
Table 9-24	XML Parameters related to Timer Control.....	84
Table 9-25	XML Parameters related to Cooling Control.....	85
Table 9-26	XML Parameters related to Device Temperature.....	86
Table 9-27	Status LED	86
Table 9-28	XML Parameter related to Test Pattern.....	87
Table 9-29	XML Parameter related to Reverse X	90
Table 9-30	XML Parameter related to Reverse Y	91
Table 9-31	XML Parameter related to Device Link Throughput Limit	92
Table 9-32	XML Parameter related to Device User ID.....	92
Table 9-33	XML Parameter related to Device Reset	92
Table 9-34	XML Parameters related to User Set Control	93
Table 9-35	XML Parameters related to Sequencer Control	95

Figures

Figure 5-1	Camera Block Diagram.....	22
Figure 5-2	Spectral Response.....	23
Figure 5-3	VP-103MX2-M/C24I Mechanical Dimension	24
Figure 7-1	VP-103MX2-M/C24I Back Panel	27
Figure 7-2	Micro-BNC Connector	28
Figure 7-3	Pin Assignments for Power Input Receptacle	29
Figure 7-4	Pin Assignments for Control Receptacle	30
Figure 7-5	Trigger Input Schematic.....	31
Figure 7-6	Strobe Output Schematic	31
Figure 8-1	Exposure Start Triggering.....	34
Figure 8-2	Frame Acquisition with Software Trigger Signal	40
Figure 8-3	External Trigger Delay	43
Figure 8-4	Timed Exposure Mode	44
Figure 8-5	Trigger Overlapped with Timed Exposure Mode	44
Figure 8-6	TriggerWidth Exposure Mode	45
Figure 8-7	Overlapped Exposure and Readout	47
Figure 8-8	Global Shutter	49
Figure 9-1	Sequence of signal processing to correct images	52
Figure 9-2	Region of Interest.....	53
Figure 9-3	Multi-ROI.....	58
Figure 9-4	2 × 2 Binning and 4 × 4 Binning	61
Figure 9-5	CXP Link Configuration	62
Figure 9-6	VP-103MX2-M/C24I Pixel Format.....	63
Figure 9-7	Effective Data ROI.....	64

Figure 9-8	Sequence of signal processing and Black Level	68
Figure 9-9	Location of Defect Pixel to be corrected	70
Figure 9-10	Generation and Application of Flat Field Data.....	76
Figure 9-11	Bilinear Interpolated Magnification	76
Figure 9-12	Flat Field Data Selector.....	78
Figure 9-13	User Output	82
Figure 9-14	Exposure Active Signal.....	82
Figure 9-15	Debounce	83
Figure 9-16	Timer Signal.....	85
Figure 9-17	Grey Horizontal Ramp.....	87
Figure 9-18	Grey Diagonal Ramp.....	88
Figure 9-19	Grey Diagonal Ramp Moving.....	88
Figure 9-20	Sensor Specific	89
Figure 9-21	Original Image	90
Figure 9-22	Reverse X Image.....	90
Figure 9-23	Original Image	91
Figure 9-24	Reverse Y Image.....	91
Figure 9-25	User Set Control.....	94
Figure 9-26	Sequencer Diagram (Use Case).....	97

Chapter 1. Precautions

General



- Do not drop, disassemble, repair or alter the device. Doing so may damage the camera electronics and cause an electric shock.
- Do not let children or companion animals touch the device without supervision.
- Stop using the device and contact the nearest dealer or manufacturer for technical assistance if liquid such as water, drinks or chemicals gets into the device.
- Do not touch the device with wet hands. Doing so may cause an electric shock.
- Make sure that the temperature of the camera does not exceed the temperature range specified in 5.2 Specifications. Otherwise the device may be damaged by extreme temperature.

Installation and Maintenance



- Do not install in dusty or dirty areas - or near an air conditioner or heater to reduce the risk of damage to the device.
- Avoid installing and operating in an extreme environment where vibration, heat, humidity, dust, strong magnetic fields, explosive/corrosive mists or gases are present.
- Do not apply excessive vibration and shock to the device. This may damage the device.
- Avoid direct exposure to a high intensity light source. This may damage the image sensor.
- Do not install the device under unstable lighting conditions. Severe lighting change will affect the quality of the image produced by the device.
- Do not use solvents or thinners to clean the surface of the device. This can damage the surface finish.

Power Supply



- Applying incorrect power can damage the camera. If the voltage applied to the camera is greater or less than the camera's nominal voltage, the camera may be damaged or operate erratically. Please refer to 5.2 Specifications for the camera's nominal voltage.
※ Vieworks Co., Ltd. does NOT provide power supplies with the devices.
- Make sure the power is turned off before connecting the power cord to the camera. Otherwise, damage to the camera may result.

Cleaning the Sensor Surface

Avoid cleaning the surface of the camera's sensor if possible. If you have dust or foreign matter on the sensor surface that will not blow off, use a soft lint free cotton bud dampened with a small quantity of high quality lens cleaner. Because electrostatic discharge (ESD) can damage the sensor, you must use a cloth (e.g. cotton) that will not generate static during cleaning.



Avoid dust or foreign matter on the sensor surface.

The camera is shipped with a protective plastic seal on the camera front. To prevent collecting dust or foreign matter on the camera sensor, make sure that you always put the protective seal in place when there is no lens mounted on the camera. In addition, make sure to always point the camera downward when there is no protective seal on the camera front or no lens mounted.

Procedures for Cleaning the Sensor

If you have dust or foreign matter on the sensor surface, follow the procedures below to wipe off.

1. Remove a contaminant by using an ionizing air gun.
If this step does not remove the contaminant, proceed to the next step.
2. Clean the contaminant on the sensor using one drop of lens cleaner on a non-fluffy cotton bud.
3. Wipe the cotton bud gently in only one direction (either left to right or right to left). Avoid wiping back and forth with the same cotton bud in order to ensure that the contaminants are removed and not simply transferred to a new location on the sensor surface.
4. Mount a lens, set the lens at a smaller aperture (e.g. F8), and then acquire images under bright lighting conditions. Check the images on the monitor for dark spots or stripes caused by the contaminant. Repeat the steps above until there is no contaminant present.



Caution!

If the sensor is damaged due to electrostatic discharge or the sensor surface is scratched during cleaning, the warranty is void.

Chapter 2. Warranty

Do not open the housing of the camera. The warranty becomes void if the housing is opened. For information about the warranty, please contact your local dealer or factory representative.

Chapter 3. Compliance & Certifications

3.1 FCC Compliance

This equipment has been tested and found to comply with the limits for a Class A digital device, pursuant to part 15 of the FCC Rules. These limits are designed to provide reasonable protection against harmful interference when the equipment is operated in a commercial environment. This equipment generates, uses, and can radiate radio frequency energy and, if not installed and used in accordance with the instruction manual, may cause harmful interference to radio communications. Operation of this equipment in a residential area is likely to cause harmful interference in which case the user will be required to correct the interference at his own expenses.

3.2 CE : DoC

EMC Directive 2014/30/EU

EN 55032:2012 (Class A), EN 55024:2010

Class A

3.3 KC

KCC Statement

Type	Description
Class A (Broadcasting Communication Device for Office Use)	This device obtained EMC registration for office use (Class A), and may be used in places other than home. Sellers and/or users need to take note of this.

Chapter 4. Package Components

Package Components



VP-103MX2-M/C24I with M72 × 0.75 mount

Chapter 5. Product Specifications

5.1 Overview

The VP-103MX2-M/C24I, the latest model of the industrial proven VP series, is a new 103-megapixel CoaXPress camera and adopts the cutting-edge High Speed CMOS Image Sensor. The VP-103MX2-M/C24I camera offers up to 24.7 frames per second at 11,264 × 9,200 resolution. This camera uses thermoelectric Peltier (TEC) cooling technology developed for and used by many demanding medical market customers. The TEC maintains the operating temperature of the CMOS image sensor at up to 15 degrees below ambient temperature. This camera provides a stable operating condition and the ability to expose for a long period of time to increase camera sensitivity. Featuring the stable operating capability and high resolution, this camera is ideal for demanding applications such as FPD, PCB and semiconductor inspections.

Main Features

- High Speed 103 Megapixel CMOS Image Sensor
- Thermoelectric Peltier Cooling – about 15 degrees below ambient temperature
- Minimizing the number of hot pixels with TEC
- CoaXPress 2.0 Interface up to 24.7 fps at 50 Gbps using 4 channels
- Output Channel: CXP-6/10/12 × 1/2/4
- Electronic Exposure Time Control (Global Shutter)
- Output Pixel Format: 8/10/12 bit
- Line Output
- Defective Pixel Correction
- Gain / Black Level Control
- Test Pattern
- Temperature Monitor
- Field Upgrade
- DSNU and PRNU Correction
- Flat Field Correction

5.2 Specifications

Technical specifications for the VP-103MX2-M/C24I are as follows.

Specifications	VP-103MX2-M/C24I	
Resolution (H×V)	11264 × 9200	
Sensor	GMAX32103	
Sensor Size (Diagonal)	36.1 mm × 29.4 mm (photo sensitive area)	
Sensor Type	High Speed CMOS Image Sensor	
Pixel Size	3.2 μm × 3.2 μm	
Interface	CXP-12 4 Channels	
Max. Frame Rate (8 bit)	CXP6 × 4	22.8 fps
	CXP10 × 4	24.7 fps
	CXP12 × 4	24.7 fps
Exposure Time	1 μs ~ 60 s (1 μs step)	
Partial Scan(Max. Speed)	850.2 fps at 4 Lines, CXP-12(4 channels)	
Pixel Data Format	Mono	Mono 8/10/12 bit
	Color	GB Bayer 8/10/12 bit
Electronic Shutter	Global Shutter	
Gain Control	Analog	1.4× ~ 5.2×
	Digital	1.0× ~ 32.0×
Digital Black Level	0~255 LSB in 12 bit Sensor Resolution	
Exposure Mode	Free-Run, Timed, TriggerWidth	
External Trigger	3.3 ~ 24.0 V, 10mA, Logical Level Input Optically Isolated CoaXPress Control Port(CXP only)	
Software Trigger	Asynchronous, Programmable via Camera API(CXP only)	
Digital I/O	TTL Level	
	Exposure Active, Frame Active, User Output, Timer, Strobe Output	
Dynamic Range	12 bit: Typical 66 dB (EMVA 1288)	
Cooling Method	Standard Cooling with a Fan	
Mechanical (W×H×L)	100 mm × 100 mm × 120 mm, 1.55 kg, M72-mount	
Environmental	Operating: 0°C ~ 40°C, Storage: -40°C ~ 70°C	
Lens Mount	M72-mount	
Power	External	11~24 V DC
	Dissipation	Typical 30 W, Maximum 32 W
Compliance	CE, FCC, KC	

Table 5-1 Specifications VP-103MX2-M/C24I

5.3 Camera Block Diagram

The block diagram of VP-103MX2-M/C24I is shown below.

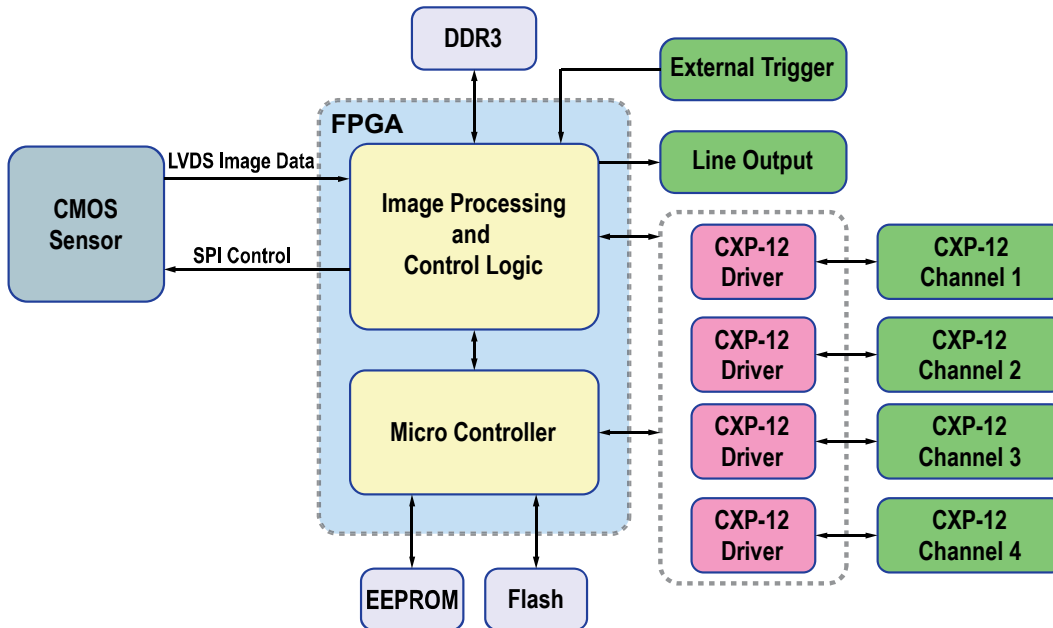

Figure 5-1 Camera Block Diagram

All controls and data processing of the camera are carried out in one FPGA chip. The FPGA generally consists of a 32-bit RISC Micro-Controller and Processing & Control logic. The Micro-Controller receives commands from the user through the CoaXPress 2.0 interface and then processes them.

The Processing & Control logic processes the image data received from the CMOS image sensor and then transmits data through the CoaXPress 2.0 interface. The Processing & Control logic also controls time-sensitive trigger inputs and output signals. Furthermore, Flash and DDR3 are installed outside FPGA. The DDR3 is used to process images and the Flash stores the firmware to operate the Micro-Controller.

5.4 Spectral Response

The following graphs show the spectral response for the VP-103MX2-M/C24I.

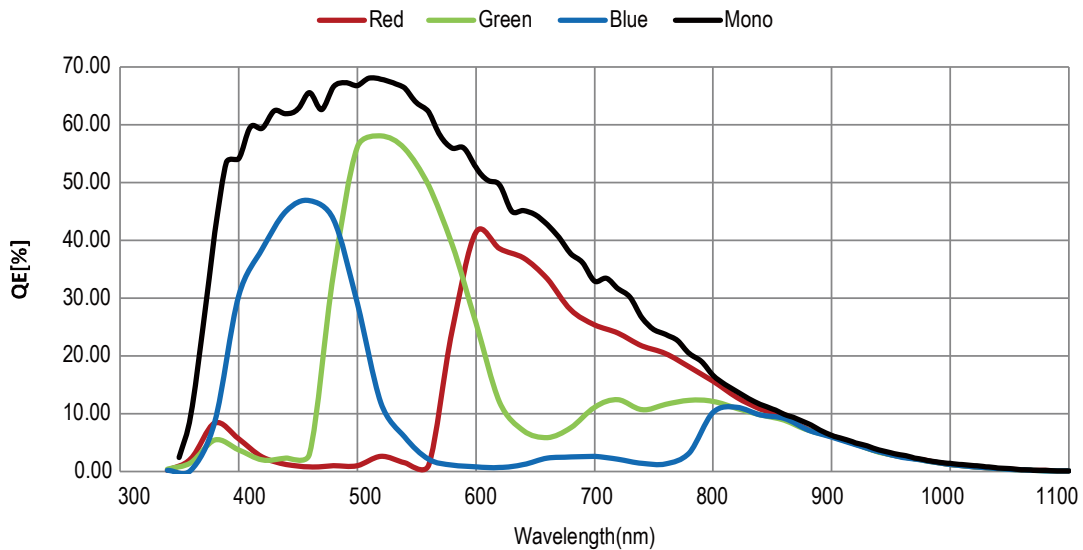

Figure 5-2 Spectral Response

5.5 Mechanical Specification

The camera dimensions in millimeters are shown in the following figure.

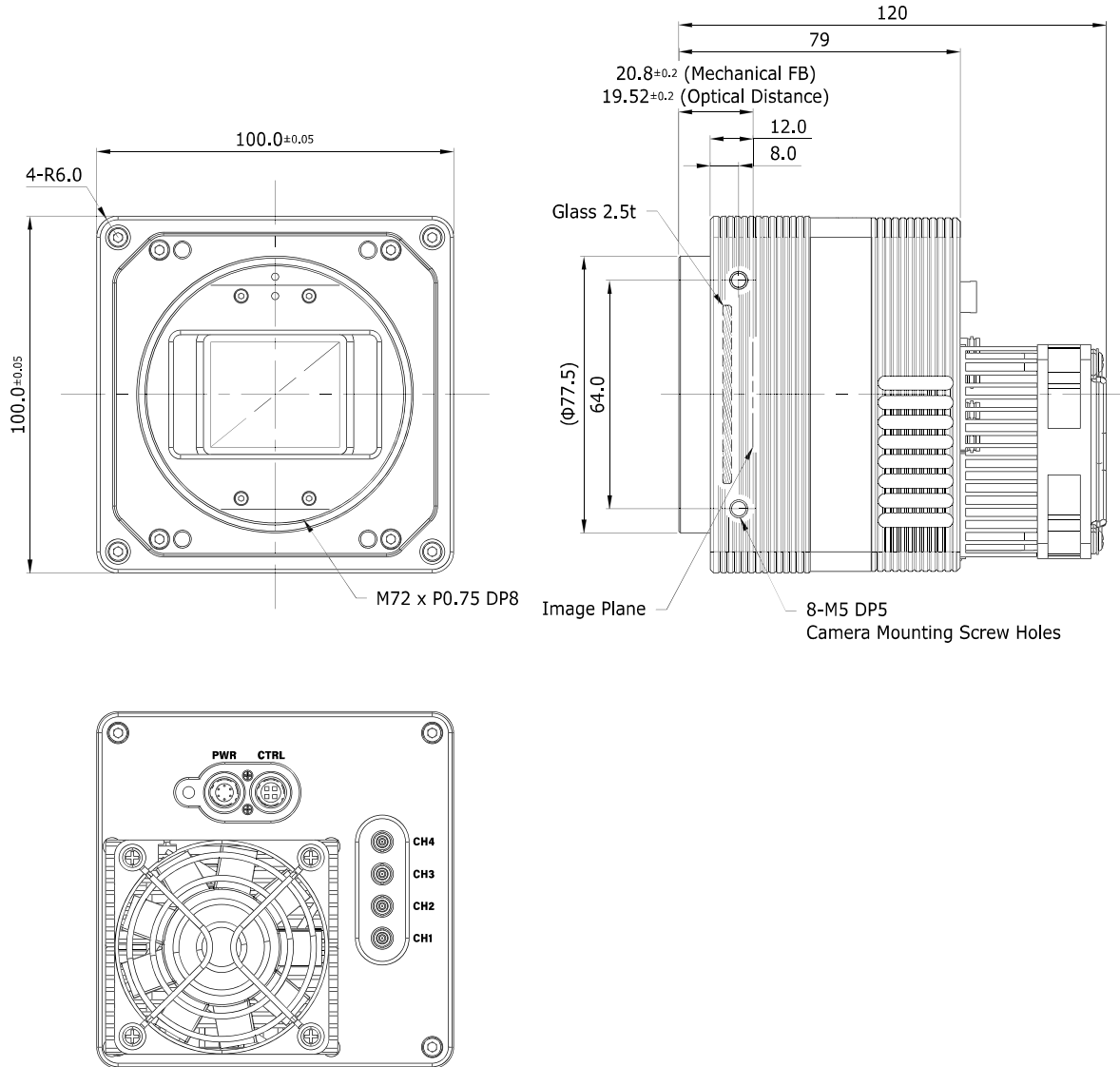

Figure 5-3 VP-103MX2-M/C24I Mechanical Dimension

5.5.1 Camera Mounting and Heat Dissipation

Camera Mounting Recommendations for Antivibration

When you mount a camera in a poor condition, the fan equipped on the camera may amplify vibrations which can lead to blurry images. Follow the instructions below to prevent and/or reduce vibrations caused by the fan.

- Fix the camera's front or side surface by using at least four screws.
- Prevent ingress of foreign objects between the camera and system surfaces.
- Keep the camera's center of gravity as near as possible to the system's center of gravity.
- If your lens' weight or size is greater than the camera's, make and use proper mounting brackets to support the lens.
- Prevent foreign matters from falling into the fan. This may cause damage to the fan blades.

Camera Mounting Recommendations for Effective Heat Dissipation

- Do not obstruct the air inlets and outlets of the fan.
- If the fan is not available, leave enough space around the heat sink so that heat can be easily dissipated through the heat sink by natural convection.
- If the fan is not available, mount the camera on a metal structure made of high thermal conductive materials (e.g. Aluminum) to properly dissipate the heat generated by the camera.
- The contact surface of the camera must be at least 30% of the camera's Front-Block.

Chapter 6. Connecting the Camera

The following instructions assume that you have installed a CoaXPress 2.0 Frame Grabber (hereinafter 'CXP-12 Frame Grabber') in your computer including related software. The procedure below also assumes that you may attempt to configure a link between a camera and CXP-12 Frame Grabber by using four coax cables. For more detailed information, refer to your CXP-12 Frame Grabber User Manual.

To connect the camera to your PC, follow the steps below.

1. Make sure that the power supply is not connected to the camera and your computer is turned off.
2. Plug one end of a coax cable into the CH1 of the CXP connector on the camera and the other end of the coax cable into the CH1 of the CXP-12 Frame Grabber in your computer. Then, connect the CH2, CH3 and CH4 of the CXP connector on the camera to the CH2, CH3 and CH4 of the CXP-12 Frame Grabber respectively using the other three coax cables.
 - Connect the plug of the power adapter to the power input receptacle on the camera.
 - Plug the power adapter into a working electrical outlet.
3. Verify all the cable connections are secure.

6.1 Precaution to Center the Image Sensor

- Users do not need to center the image sensor as it is adjusted as factory default settings.
- When you need to adjust the center of the image sensor, please contact your local dealer or the manufacturer for technical assistance.

6.2 Precaution about Blurring Compared to the Center

- Users do not need to adjust the tilt as it is adjusted as factory default settings.
- If the tilt settings need to be adjusted inevitably, please contact your local dealer or factory representative for technical support.

6.3 Installing Vieworks Imaging Solution

You can download the Vieworks Imaging Solution at <http://vision.vieworks.com>. You should perform the software installation first and then the hardware installation.

Chapter 7. Camera Interface

7.1 General Description

As shown in the following figure, three types of connectors and an LED indicator are located on the back of the camera and have the functions as follows:

- | | |
|---------------------------------|---|
| ① Status LED: | displays power status and operation mode. |
| ② 6 pin Power Input Receptacle: | supplies power to the camera. |
| ③ 4 pin Control I/O Receptacle: | provides access to the camera's I/O lines. |
| ④ CoaXPress Connector: | transmits video data and controls the camera. |

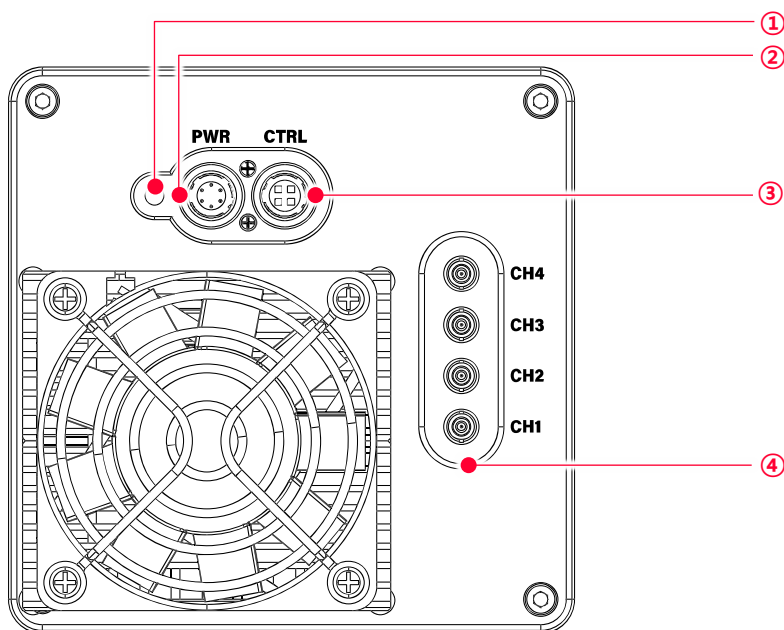

Figure 7-1 VP-103MX2-M/C24I Back Panel

7.2 CoaXPress Connector

CoaXPress protocol includes an automatic link detection mechanism (Plug and Play) to correctly detect the camera to the CXP-12 Frame Grabber connection. The connection between the camera and CXP-12 Frame Grabber uses a coax (also known as 'coaxial') cable and provides up to 12.5 Gbps bit rate per cable.

7.2.1 Micro-BNC Connector

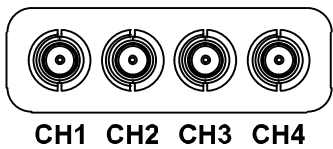

Figure 7-2 Micro-BNC Connector

The CoaXPress connectors on the VP-103MX2-M/C24I camera comply with the CoaXPress 2.0 standard and the following table shows the channel assignments.

Channel	Max. Bit Rate per Coax	Type
CH1	12.5 Gbps	Master Connection
CH2	12.5 Gbps	Extension Connection
CH3	12.5 Gbps	Extension Connection
CH4	12.5 Gbps	Extension Connection

Table 7-1 Channel Assignments for Micro-BNC Connector



Note:

When you connect a camera to a CXP-12 Frame Grabber using coax cables, make sure to connect the cables to their correct channels. If you connect the CH1 of the CXP connector on the camera to a channel other than CH1 of the CXP-12 Frame Grabber, the camera may not transmit images properly or the communication between the computer and camera may fail.

7.3 Power Input Receptacle

The power input receptacle is a Hirose 6-pin connector (part # HR10A-7R-6PB). The pin assignments and configurations are as follows:

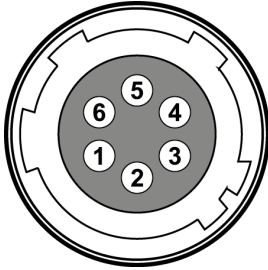

Figure 7-3 Pin Assignments for Power Input Receptacle

Pin Number	Signal	Type	Description
1, 2, 3	+ 12V DC	Input	DC Power Input
4, 5, 6	DC Ground	Input	DC Ground

Table 7-2 Pin Configurations for Power Input Receptacle



Note:

- A recommended mating connector for the Hirose 6-pin connector is the Hirose 6-pin plug (part # HR10A-7P-6S) or the equivalent.
- It is recommended that you use the power adapter, which has at least 3 A current output at 12 V DC $\pm 10\%$ voltage output (You need to purchase a power adapter separately.).

Precaution for Power Input



Caution!

- Make sure the power is turned off before connecting the power cord to the camera. Otherwise, damage to the camera may result.
- If the voltage applied to the camera is greater than specified in the specifications, damage to the camera may result.

7.4 Control Receptacle

The control receptacle is a Hirose 4-pin connector (part # HR10A-7R-4S) and consists of an external trigger signal input and strobe output ports. The pin assignments and configurations are as follows:

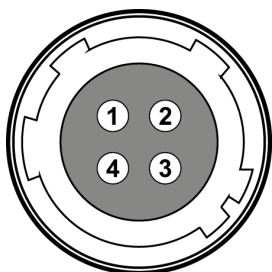

Figure 7-4 Pin Assignments for Control Receptacle

Pin Number	Signal	Type	Description
1	Trigger Input	Input	3.3 V – 5.0 V TTL Input Input Resistance: 1 k Ω
2	Trigger Input	Input	-
3	DC Ground	-	DC Ground
4	Line 1 Output	Output	3.3 V TTL Output Output Resistance: 47 Ω

Table 7-3 Pin Configurations for Control Receptacle



Note:

A recommended mating connector for the Hirose 4-pin connector is the Hirose 4-pin plug (part # HR10A-7P-4P) or the equivalent.

7.5 Trigger Input Circuit

The following figure shows trigger signal input circuit of the 4-pin connector. Transmitted trigger signal is applied to the internal circuit through a photo coupler. With the Debounce feature, you can specify the width of input signal to be considered as a valid input signal. An external trigger circuit example is shown below.

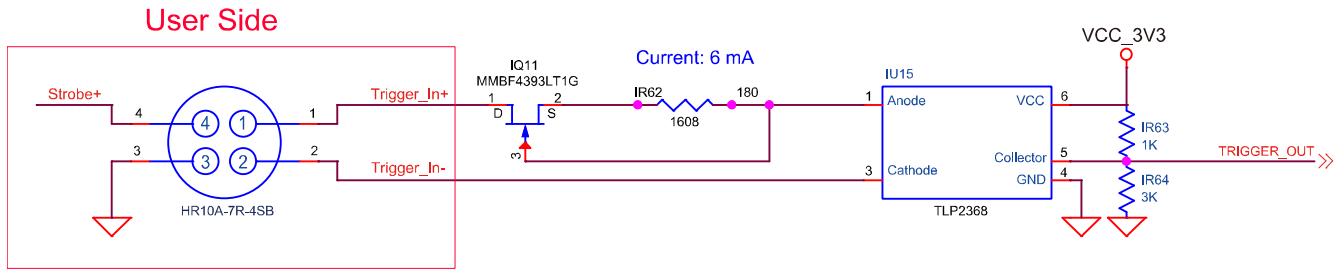

Figure 7-5 Trigger Input Schematic

7.6 Strobe Output Circuit

The strobe output signal comes out through a 3.3 V output level of TTL Driver IC. A pulse width of signal is synchronized with an exposure (shutter) signal of the camera.

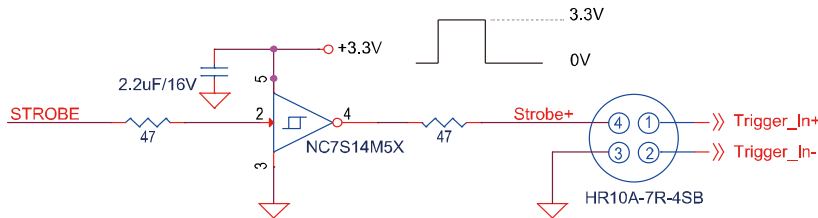

Figure 7-6 Strobe Output Schematic

Chapter 8. Acquisition Control

This chapter provides detailed information about controlling image acquisition.

- Triggering image acquisition
- Setting the exposure time
- Controlling the camera's image acquisition rate
- Variation of the camera's maximum allowed image acquisition rate according to the camera settings

8.1 Overview

This section presents an overview of the elements involved with controlling the acquisition of images.

The followings are involved in controlling the acquisition of images.

- Acquisition Start and Acquisition Stop commands and the Acquisition Mode parameter
- Exposure start trigger
- Exposure time control
- Frame acquisition process on the camera
- Global shutter
- Maximum Allowed Frame Rate

**Note:**

A recommended mating connector for the Hirose 4-pin connector is the Hirose 4-pin plug (part # HR10A-7P-4P) or the equivalent.

8.2 Acquisition Start/Stop Commands and Acquisition Mode

This section describes function available to use via the followings:

- Acquisition Start/Stop commands
- Acquisition Mode

The details about each item above is described in the order from the following section.

8.2.1 Acquisition Start/Stop Commands

The Acquisition Start command prepares the camera to acquire images. The camera cannot acquire images unless an Acquisition Start command has first been executed.

Executing an Acquisition Stop command terminates the camera's ability to acquire images.

8.2.2 Acquisition Mode

The Acquisition Mode parameter affects directly how the Acquisition Start command works. There are three of types available to select in this parameter as follows:

- Continuous:
Acquires frames continuously once the Acquisition Start command is called until the Acquisition Stop command is called.
- SingleFrame:
Acquires one single frame after the Acquisition Start command is called, and then, finishes acquiring images with calling the Acquisition Stop command automatically.
- MultiFrame:
Acquires frames as many as the numbers designated on the AcquisitionFrameCount parameter after the Acquisition Start command is called, and then, finishes acquiring images with calling the Acquisition Stop command automatically.

**Note:**

The Acquisition Start command will remain in effect until you execute an Acquisition Stop command. Once an Acquisition Stop command has been executed, the camera will not be able to acquire frames until a new Acquisition Start command is executed. If a user calls an Acquisition Stop command on the way of image acquisition, the work will finish after finishing the ongoing acquisition all.

8.2.3 Exposure Start Trigger

Applying an exposure start trigger signal to the camera will exit the camera from the waiting for exposure start trigger acquisition status and will begin the process of exposing and reading out a frame (see Figure 8-1). As soon as the camera is ready to accept another exposure start trigger signal, it will return to the waiting for exposure start trigger acquisition status. A new exposure start trigger signal can then be applied to the camera to begin another frame exposure. The exposure start trigger has two modes: off and on.

If the **Trigger Mode** parameter is set to **Off**, the camera will generate all required exposure start trigger signals internally, and you do not need to apply exposure start trigger signals to the camera. The rate at which the camera will generate the signals and acquire frames will be determined by the way that you set several frame rate related parameters.

If the **Trigger Mode** parameter is set to **On**, you must trigger exposure start by applying exposure start trigger signals to the camera. Each time a trigger signal is applied, the camera will begin a frame exposure. When exposure start is being triggered in this manner, it is important that you do not attempt to trigger frames at a rate that is greater than the maximum allowed (There is a detailed explanation about the maximum allowed frame rate at the end of this chapter.). Exposure start trigger signals applied to the camera when it is not in a waiting for exposure start trigger acquisition status will be ignored.

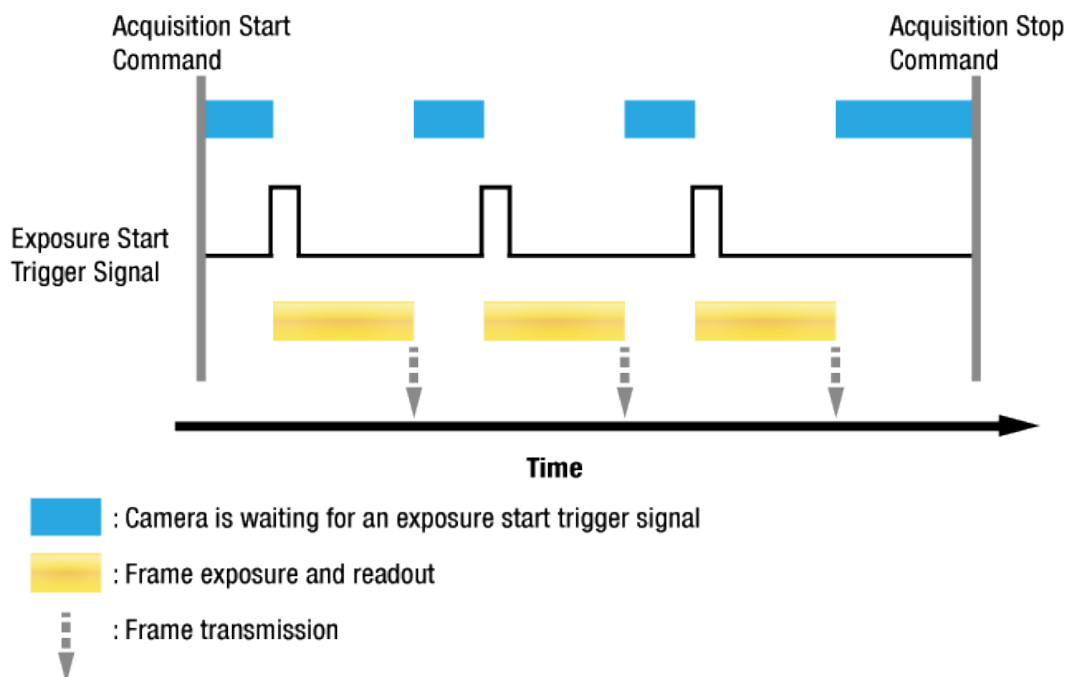

Figure 8-1 Exposure Start Triggering

8.2.4 Applying Trigger Signals

The paragraphs above mention “applying a trigger signal”. There are five ways to apply an exposure start trigger signal to the camera: via Software, via UserOutput0, via LinkTrigger0, via Timer0 Active or via Line0 (commonly referred to a hardware).

- To apply trigger signals via Software, you must set the Trigger Source parameter to Software. At that point, each time a Trigger Software command is executed, the exposure start trigger signal will be applied to the camera.
- To apply trigger signals via UserOutput0, you must set the Trigger Source parameter to UserOutput0. At that point, you can apply an exposure start trigger signal to the camera by switching the User Output Value parameter between On (rise) and Off (fall).
- To apply trigger signals via CH1 of the CXP-12 Frame Grabber, you must set the Trigger Source parameter to LinkTrigger0. At that point, each time a proper CoaXPress trigger signal is applied to the camera by using the APIs provided by a CXP-12 Frame Grabber manufacturer, the exposure start trigger signal will be applied to the camera. For more information, refer to your CXP-12 Frame Grabber User Manual.
- To apply trigger signals via the user-defined Timer feature, you must set the Trigger Source parameter to Timer0 Active. When you set the Timer Trigger Source parameter to Line0 in the Counter And Timer Control category, you can apply an exposure start trigger signal to the camera by using a Timer that uses the Line0 signal as the source signal.
- To apply trigger signals via hardware (external), you must set the Trigger Source parameter to Line0. At that point, each time a proper electrical signal is applied to the camera, an occurrence of the exposure start trigger signal will be recognized by the camera.

8.2.5 Exposure Time Control

When an exposure start trigger signal is applied to the camera, the camera will begin to acquire a frame.

A critical aspect of frame acquisition is how long the pixels in the camera's sensor will be exposed to light during the frame acquisition.

If the **Trigger Source** parameter is set to **Software**, the **Exposure Time** parameter will determine the exposure time for each frame.

If the **Trigger Source** parameter is set to **UserOutput0**, **LinkTrigger0**, **Timer0 Active** or **Line0**, there are two modes of operation: **Timed** and **TriggerWidth**.

With the **Timed** mode, the **Exposure Time** parameter will determine the exposure time for each frame.

With the **TriggerWidth** mode, the way that you manipulate the rise and fall of the User Output, CoaXPress, Timer or hardware (external) signal will determine the exposure time. The **TriggerWidth** mode is especially useful if you want to change the exposure time from frame to frame.

8.3 Exposure Start Trigger

The **Trigger Selector** parameter is used to select a type of trigger and only the **Exposure Start** trigger is available on the VP-103MX2-M/C24I camera. The **Exposure Start** trigger is used to begin frame acquisition. Exposure start trigger signals can be generated within the camera or may be applied externally by setting the **Trigger Source** parameter to **Software**, **UserOutput0**, **LinkTrigger0**, **Timer0 Active** or **Line0**. If an exposure start trigger signal is applied to the camera, the camera will begin to expose a frame.

8.3.1 Trigger Mode

The main parameter associated with the exposure start trigger is the **Trigger Mode** parameter. The **Trigger Mode** parameter for the exposure start trigger has two available settings: **Off** and **On**.

Trigger Mode = Off

When the **Trigger Mode** parameter is set to **Off**, the camera will generate all required exposure start trigger signals internally, and you do not need to apply exposure start trigger signals to the camera.

If the **Trigger Mode** parameter is set to **Off**, the camera will automatically begin generating exposure start trigger signals when it receives an **Acquisition Start** command. The camera will continue to generate exposure start trigger signals until it receives an **Acquisition Stop** command.



Free-Run

When you set the **Trigger Mode** parameter to **Off**, the camera will generate all required trigger signals internally. When the camera is set this way, it will constantly acquire images without any need for triggering by the user. This use case commonly referred as "free run".

The rate at which the exposure start trigger signals are generated may be determined by the camera's **Acquisition Frame Rate** parameter.

- If the parameter is set to a value less than the maximum allowed frame rate with the current camera settings, the camera will generate exposure start trigger signals at the rate specified by the parameter setting.
- If the parameter is set to a value greater than the maximum allowed frame rate with the current camera settings, the camera will generate exposure start trigger signals at the maximum allowed frame rate.

Exposure Time Control with Trigger Mode = Off

When the **Trigger Mode** parameter is set to **Off**, the exposure time for each frame acquisition is determined by the value of the camera's **Exposure Time** parameter. For more information about the **Exposure Time** parameter, see [8.4 Setting the Exposure Time](#).

Trigger Mode = On

When the **Trigger Mode** parameter is set to **On**, you must apply an exposure start trigger signal to the camera each time you want to begin a frame acquisition. The **Trigger Source** parameter specifies the source signal that will act as the exposure start trigger signal.

The available settings for the **Trigger Source** parameter are:

- **Software**
- **UserOutput0**
- **LinkTrigger0**: For more information, refer to your [CXP-12 Frame Grabber User Manual](#).
- **Timer0Active**: For more information, refer to [9.19 Timer Control](#).
- **Line0**: Refer to [7.5 Trigger Input Circuit](#) for more information.

You must also set the **Trigger Activation** parameter after setting the **Trigger Source** parameter.

The available settings for the **Trigger Activation** parameter are:

- **Falling Edge**: Specifies that a falling edge of the electrical signal will act as the exposure start trigger.
- **Rising Edge**: Specifies that a rising edge of the electrical signal will act as the exposure start trigger.

Exposure Time Control with Trigger Mode = On

When the **Trigger Mode** parameter is set to **On** and the **Trigger Source** parameter is set to **Software**, the exposure time for each frame acquisition is determined by the value of the camera's **Exposure Time** parameter.

When the **Trigger Mode** parameter is set to **On** and the **Trigger Source** parameter is set to **LinkTrigger0** or **Line0**, the exposure time for each frame acquisition will be determined by the **Exposure Mode** parameter settings as follows:

- **Exposure Mode = Timed:** Exposure time can be controlled with the **Exposure Time** parameter.
- **Exposure Mode = TriggerWidth:** Exposure time can be controlled by manipulating the external trigger signal.

When the **Trigger Mode** parameter is set to **On** and the **Trigger Source** parameter is set to **Timer0 Active**, the exposure time for each frame acquisition will be determined by the **Exposure Mode** parameter settings as follows:

- **Exposure Mode = Timed:** Exposure time can be controlled with the **Exposure Time** parameter.
- **Exposure Mode = TriggerWidth:** When you set the **Timer Trigger Activation** parameter to **Rising/Falling Edge**, the exposure time is controlled with the **Timer Duration** parameter. When you set the **Timer Trigger Activation** parameter to **Level High/Low**, the exposure time can be controlled by manipulating the external trigger signal.

When the **Trigger Mode** parameter is set to **On** and the **Trigger Source** parameter is set to **UserOutput0**, the exposure time for each frame acquisition will be determined by the **Exposure Mode** parameter settings as follows:

- **Exposure Mode = Timed:** Exposure time can be controlled with the **Exposure Time** parameter.
- **Exposure Mode = TriggerWidth:** Exposure time can be controlled by switching the **User Output Value** parameter between **On** and **Off**.

8.3.2 Using a Software Trigger Signal

If the **Trigger Mode** parameter is set to **On** and the **Trigger Source** parameter is set to **Software**, you must apply a software trigger signal (exposure start) to the camera to begin each frame acquisition. Assuming that the camera is in a **waiting for exposure start trigger** acquisition status, frame exposure will start when the software trigger signal is received by the camera. Figure 8-2 illustrates frame acquisition with a software trigger signal.

When the camera receives a software trigger signal and begins exposure, it will exit the **waiting for exposure start trigger** acquisition status because at that point, it cannot react to a new exposure start trigger signal. As soon as the camera is capable of reacting to a new exposure start trigger signal, it will automatically return to the **waiting for exposure start trigger** acquisition status.

The exposure time for each acquired frame will be determined by the value of the camera's **Exposure Time** parameter.

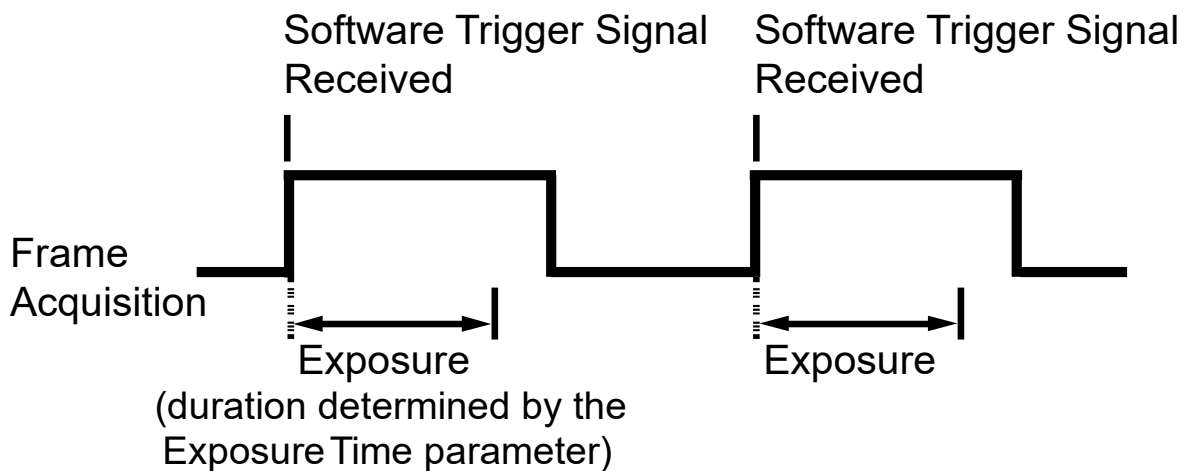

Figure 8-2 Frame Acquisition with Software Trigger Signal

When you are using a software trigger signal to start each frame acquisition, the frame rate will be determined by how often you apply a software trigger signal to the camera, and you should not attempt to trigger frame acquisition at a rate that exceeds the maximum allowed for the current camera settings (There is a detailed explanation about the maximum allowed frame rate at the end of this chapter.). Software trigger signals that are applied to the camera when it is not ready to receive them will be ignored.

8.3.3 Using a CoaXPress Trigger Signal

If the **Trigger Mode** parameter is set to **On** and the **Trigger Source** parameter is set to **LinkTrigger0**, you must apply a CoaXPress trigger signal to the camera to begin each frame acquisition. A CoaXPress trigger signal will act as the exposure start trigger signal for the camera. For more information, refer to your CXP-12 Frame Grabber User Manual.

A rising edge or a falling edge of the CoaXPress signal can be used to trigger frame acquisition. The **Trigger Activation** parameter is used to select rising edge or falling edge triggering.

Assuming that the camera is in a *waiting for exposure start trigger* acquisition status, frame acquisition will start whenever the appropriate edge transition is received by the camera.

When the camera receives a CoaXPress trigger signal and begins exposure, it will exit the *waiting for exposure start trigger* acquisition status because at that point, it cannot react to a new exposure start trigger signal.

As soon as the camera is capable of reacting to a new exposure start trigger signal, it will automatically return to the *waiting for exposure start trigger* acquisition status.

When the camera is operating under control of a CoaXPress signal, the period of the CoaXPress trigger signal will determine the rate at which the camera is acquiring frames:

$$\frac{1}{\text{CoaXPress signal period in seconds}} = \text{Frame Rate}$$

For example, if you are operating a camera with a CoaXPress trigger signal period of 50 ms(0.05 s):
So in this case, the frame rate is 20 fps.

8.3.4 Using an External Trigger Signal

If the **Trigger Mode** parameter is set to **On** and the **Trigger Source** parameter is set to **Line0**, an externally generated electrical signal injected into the Control I/O receptacle will act as the exposure start trigger signal for the camera. This type of trigger signal is generally referred to as a hardware trigger signal.

A rising edge or a falling edge of the external signal can be used to trigger frame acquisition. The **Trigger Activation** parameter is used to select rising edge or falling edge triggering.

Assuming that the camera is in a *waiting for exposure start trigger* acquisition status, frame acquisition will start whenever the appropriate edge transition is received by the camera.

When the camera receives an external trigger signal and begins exposure, it will exit the *waiting for exposure start trigger* acquisition status because at that point, it cannot react to a new exposure start trigger signal.

As soon as the camera is capable of reacting to a new exposure start trigger signal, it will automatically return to the *waiting for exposure start trigger* acquisition status.

When the camera is operating under control of an external signal, the period of the external trigger signal will determine the rate at which the camera is acquiring frames:

$$\frac{1}{\text{External signal period in seconds}} = \text{Frame Rate}$$

For example, if you are operating a camera with an External trigger signal period of 50 ms (0.05 s):

So in this case, the frame rate is 20 fps.

External Trigger Delay

When you set the Trigger Source parameter to `Timer0Active`, you can specify a delay between the receipt of a hardware trigger signal and when the trigger becomes effective.

1. Set the Timer Trigger Source parameter in the Counter And Timer Control category to `Line0`.
2. Set the Timer Delay parameter to the desired Timer delay in microseconds.
3. Set the Trigger Source parameter in the Acquisition Control category to `Timer0Active`.
4. Execute the Acquisition Start command and inject an externally generated electrical signal into the Control I/O receptacle. Then, the delay set by the Timer Delay parameter expires and the exposure for image acquisition begins.

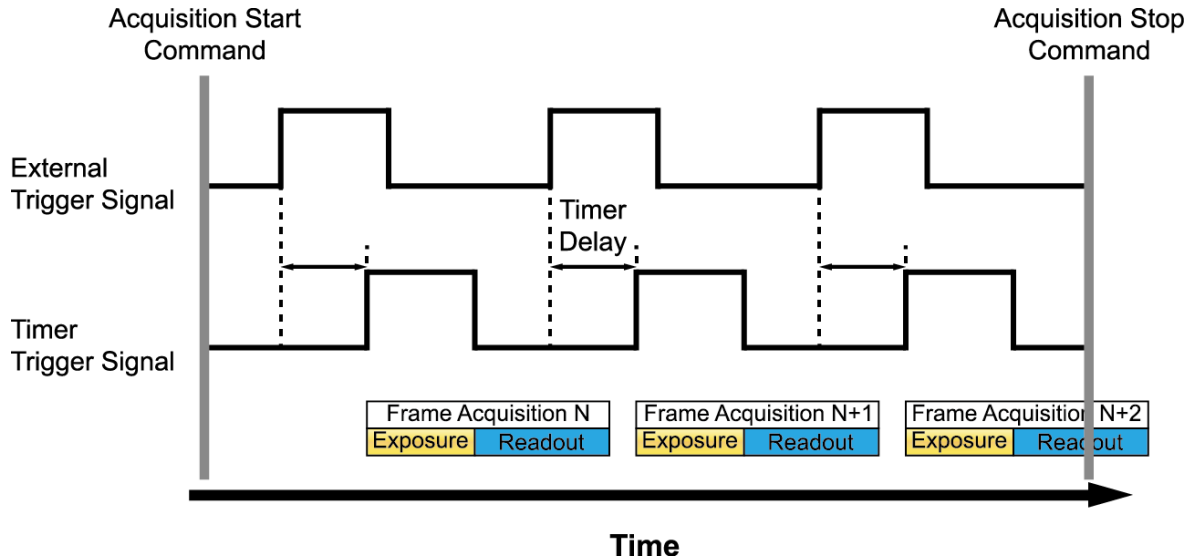

Figure 8-3 External Trigger Delay

8.3.5 Exposure Mode

If you are triggering the start of frame acquisition with an externally (CoaXPress or External) generated trigger signal, two exposure modes are available: Timed and TriggerWidth.

Timed Exposure Mode

When the **Timed** mode is selected, the exposure time for each frame acquisition is determined by the value of the camera's **Exposure Time** parameter. If the camera is set for rising edge triggering, the exposure time starts when the external trigger signal rises. If the camera is set for falling edge triggering, the exposure time starts when the external trigger signal falls. The following figure illustrates **Timed** exposure with the camera set for rising edge triggering.

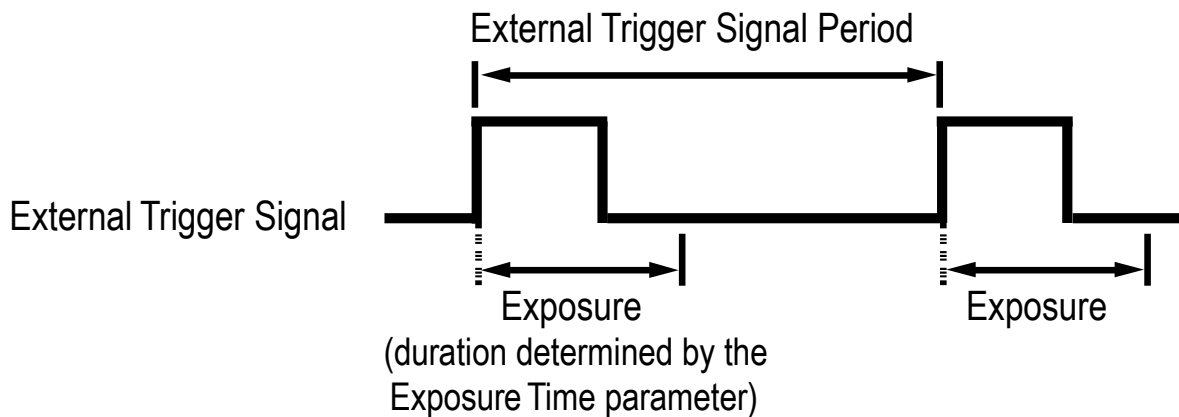

Figure 8-4 Timed Exposure Mode

Note that if you attempt to trigger a new exposure start while the previous exposure is still in progress, the trigger signal will be ignored.

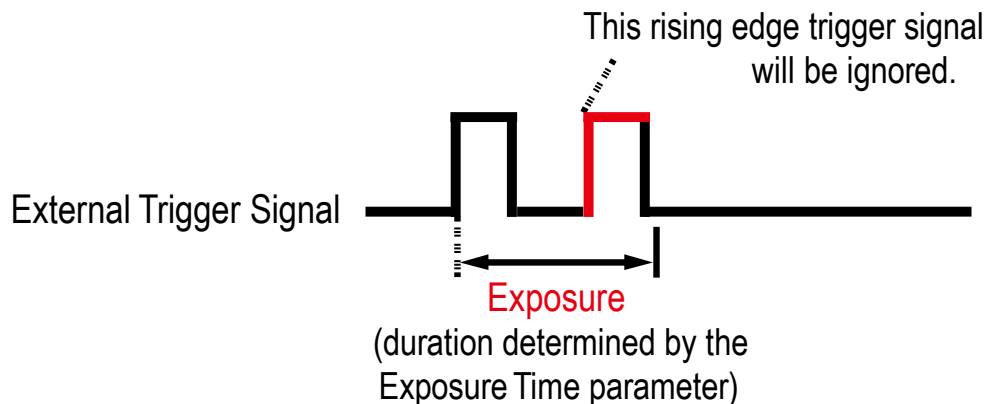

Figure 8-5 Trigger Overlapped with Timed Exposure Mode

TriggerWidth Exposure Mode

When the `TriggerWidth` exposure mode is selected, the length of the exposure for each frame acquisition will be directly controlled by the external trigger signal (CoaXPress or External). If the camera is set for rising edge triggering, the exposure time begins when the external trigger signal rises and continues until the external trigger signal falls. If the camera is set for falling edge triggering, the exposure time begins when the external trigger signal falls and continues until the external trigger signal rises. The following figure illustrates `TriggerWidth` exposure with the camera set for rising edge triggering.

`TriggerWidth` exposure is especially useful if you intend to vary the length of the exposure time for each frame.

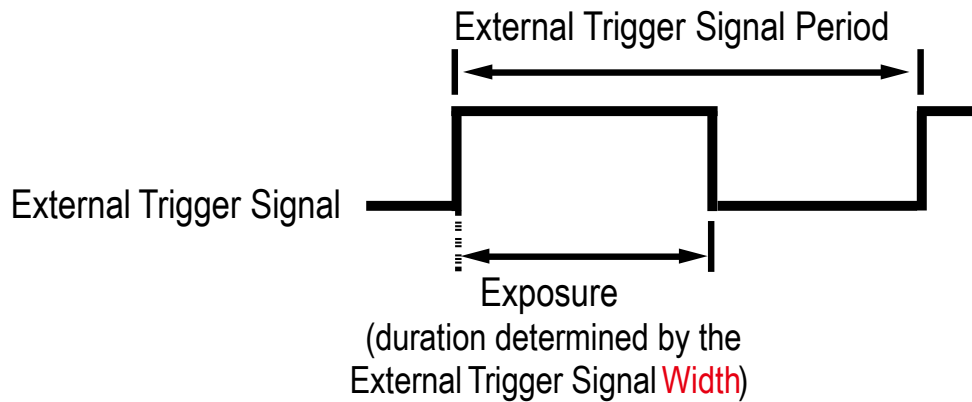

Figure 8-6 `TriggerWidth` Exposure Mode

8.4 Setting the Exposure Time

This section describes how the exposure time can be adjusted manually by setting the value of the Exposure Time parameter. If you are operating the camera in any one of the following ways, you must specify an exposure time by setting the camera's Exposure Time parameter.

- the Trigger Mode is set to Off.
- the Trigger Mode is set to On and the Trigger Source is set to Software.
- the Trigger Mode is set to On, the Trigger Source is set to UserOutput0, LinkTrigger0, Timer0 Active or Line0, and the Exposure Mode is set to Timed.

The Exposure Time parameter must not be set below a minimum specified value. The Exposure Time parameter sets the exposure time in microseconds (μs). The minimum and maximum exposure time settings for the VP-103MX2-M/C24I camera are shown in the following table.

Camera Model	Number of Channels	Minimum Exposure Time †	Maximum Exposure Time † †
VP-103MX2-M/C24I	1/2/4 Channel	1 μs	60,000,000 μs

†: The actual exposure time is determined by adding the **Exposure Time** value in the **Timed** or **TriggerWidth** items to the **Exposure Offset** value of user's choice.

††: When the **Exposure Mode** is set to **TriggerWidth**, the exposure time is controlled by the external trigger signal and has no maximum limit.

Table 8-1 Minimum and Maximum Exposure Time Setting

8.5 Overlapping Exposure with Sensor Readout

The frame acquisition process on the camera includes two distinct parts. The first part is the exposure of the pixels in the image sensor. Once exposure is complete, the second part of the process – readout of the pixel values from the sensor – takes place. In regard to this frame acquisition process, the VP-103MX2-M/C24I camera basically operates with ‘overlapped’ exposure so that the exposure for a new frame can be overlapped with the sensor readout for the previous frame.

When a new trigger signal is applied to the camera while reading out the previous frame, the camera begins the process of exposing a new frame. This situation is illustrated in the following figure with the Trigger Mode set to On, the Trigger Source set to Line0 and the Exposure Mode set to TriggerWidth.

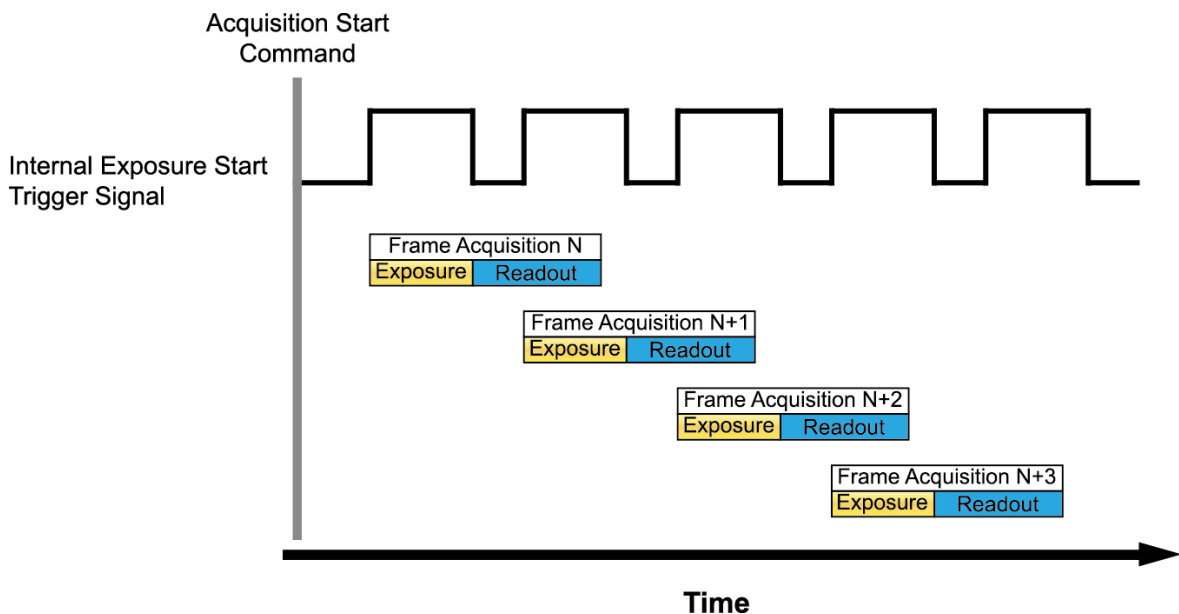

Figure 8-7 Overlapped Exposure and Readout

Determining whether your camera is operating with overlapped exposure and readout is not a matter of issuing a command or changing a setting. Rather a way that you operate the camera will determine whether the exposures and readouts are overlapped or not. If we define the “Frame Period” as the time from the start of exposure for one frame acquisition to the start of exposure for the next frame acquisition, then:

- Overlapped: Frame Period \leq Exposure Time + Readout Time

Guidelines for Overlapped Exposure

Since the VP-103MX2-M/C24I camera operates with overlapped exposure, you must keep in mind two important guidelines:

- You must not begin the exposure for a new frame while the exposure for the previous frame is in progress.
- You must not end the exposure for the current frame until the readout for the previous frame is complete.

When you are operating the camera with overlapped exposure and using an external trigger signal to trigger image acquisition, you could use the camera's Exposure Time parameter settings and timing formula to calculate when it is safe to begin each new acquisition.

8.6 Global Shutter

The VP-103MX2-M/C24I camera is equipped with an image sensor that has an electronic global shutter. When an exposure start trigger signal is applied to the camera equipped with a global shutter, exposure begins for all lines in the sensor as shown in the figure below. Exposure continues for all lines in the sensor until the programmed exposure time ends or when the exposure start trigger signal ends the exposure time if the camera is using the TriggerWidth exposure mode. At the end of the exposure time, exposure ends for all lines in the sensor. Immediately after the end of exposure, pixel data readout begins and proceeds line by line until all pixel data is read out of the sensor. A main characteristic of a global shutter is that for each frame acquisition, all of the pixels in the sensor start exposing at the same time and all end exposing at the same time. This means that image brightness tends to be more uniform over the entire area of each acquired image, and it helps to minimize problems with acquiring images of object in motion.

The camera can provide an Exposure Active output signal that will go high when the exposure time for a frame acquisition begins and will go low when the exposure time ends.

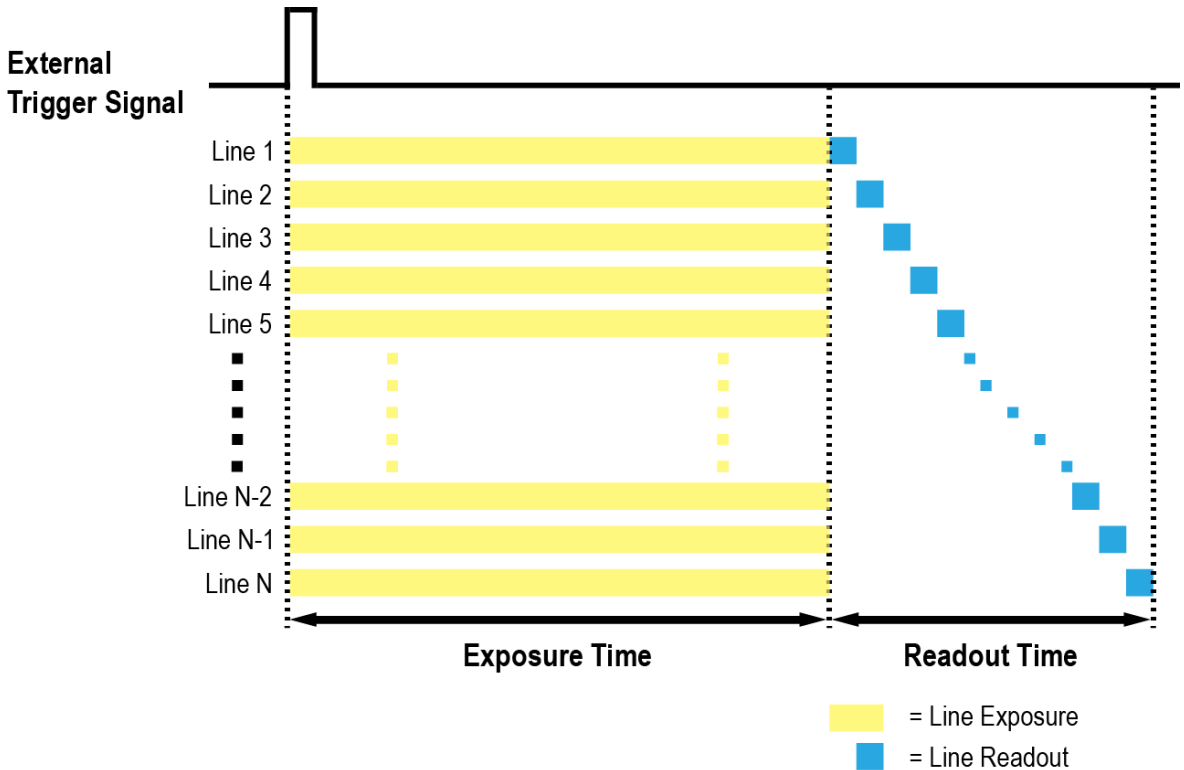

Figure 8-8 Global Shutter

8.7 Maximum Allowed Frame Rate

In general, the maximum allowed acquisition frame rate on the camera may be limited by several factors:

- The amount of time that it takes to transmit an acquired frame from the camera to your computer. The amount of time needed to transmit a frame depends on the bandwidth assigned to the camera.
- The amount of time it takes to read an acquired frame out of the image sensor and into the camera's frame buffer. This time varies depending on the setting for ROI. Frames with a smaller height and/or width take less time to read out of the sensor. The frame height and width are determined by the camera's Height and Width settings in the Image Format Control category.
- The CXP Link Configuration. When the camera is set for a CXP Link Configuration that uses more channels, it can typically transfer data out of the camera faster than when it is set for a CXP Link Configuration that uses less channels.
- The exposure time for acquired frames. If you use very long exposure time, you can acquire fewer frames per second.

8.7.1 Increasing the Maximum Allowed Frame Rate

You may find that you would like to acquire frames at a rate higher than the maximum allowed with the camera's current settings. In this case, you must adjust one or more of the factors that can influence the maximum allowed frame rate and then check to see if the maximum allowed frame rate has increased.

- The time that it takes to transmit a frame out of the camera is the main limiting factor on the frame rate. You can decrease the frame transmission time (and thus increase the maximum allowed frame rate) by using the ROI feature. Decreasing the size of the Image ROI may increase the maximum allowed frame rate. If possible, decrease the height and/or width of the Image ROI.
- If you are using a CXP Link Configuration with a low number of channels, consider using a CXP Link Configuration with a high number of channels. This will usually increase the maximum allowed frame rate.
- If you are using normal exposure times and you are using the camera at its maximum resolution, your exposure time will not normally restrict the frame rate. However, if you are using long exposure time, it is possible that your exposure time is limiting the maximum allowed frame rate. If you are using a long exposure time, try using a shorter exposure time and see if the maximum allowed frame rate increases (You may need to compensate for a lower exposure time by using a brighter light source or increasing the opening of your lens aperture.).

**Note:**

A very long exposure time severely limits the camera's maximum allowed frame rate. As an example, assume that your camera is set to use a 1 second exposure time. In this case, because each frame acquisition will take at least 1 second to be completed, the camera will only be able to acquire a maximum of one frame per second.

Chapter 9. Camera Features

9.1 Sequence of Signal Processing

To acquire the best-quality images, the VP-103MX2-M/C24I camera handles signals in the following sequence:

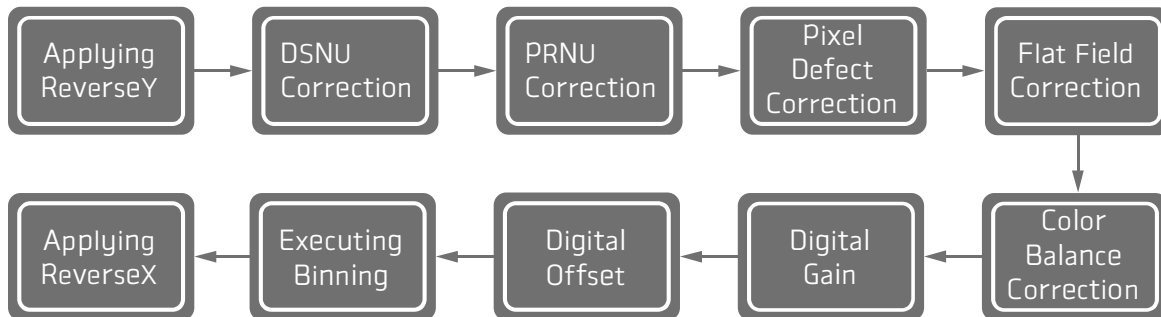

Figure 9-1 Sequence of signal processing to correct images

After finishing the current job, doing all the prior jobs to the current work again is recommended. It may affect the other jobs that have been done before the current job.

9.2 Region of Interest

The Image Region of Interest (ROI) feature allows you to specify a portion of the sensor array. You can acquire only the frame data from the specified portion of the sensor array while preserving the same quality as you acquire a frame from the entire sensor array.

With the ROI feature, you can increase the maximum allowed frame rate by decreasing the Width and/or Height parameters. The ROI is referenced to the top left corner [origin (0, 0)] of the sensor array as shown below.

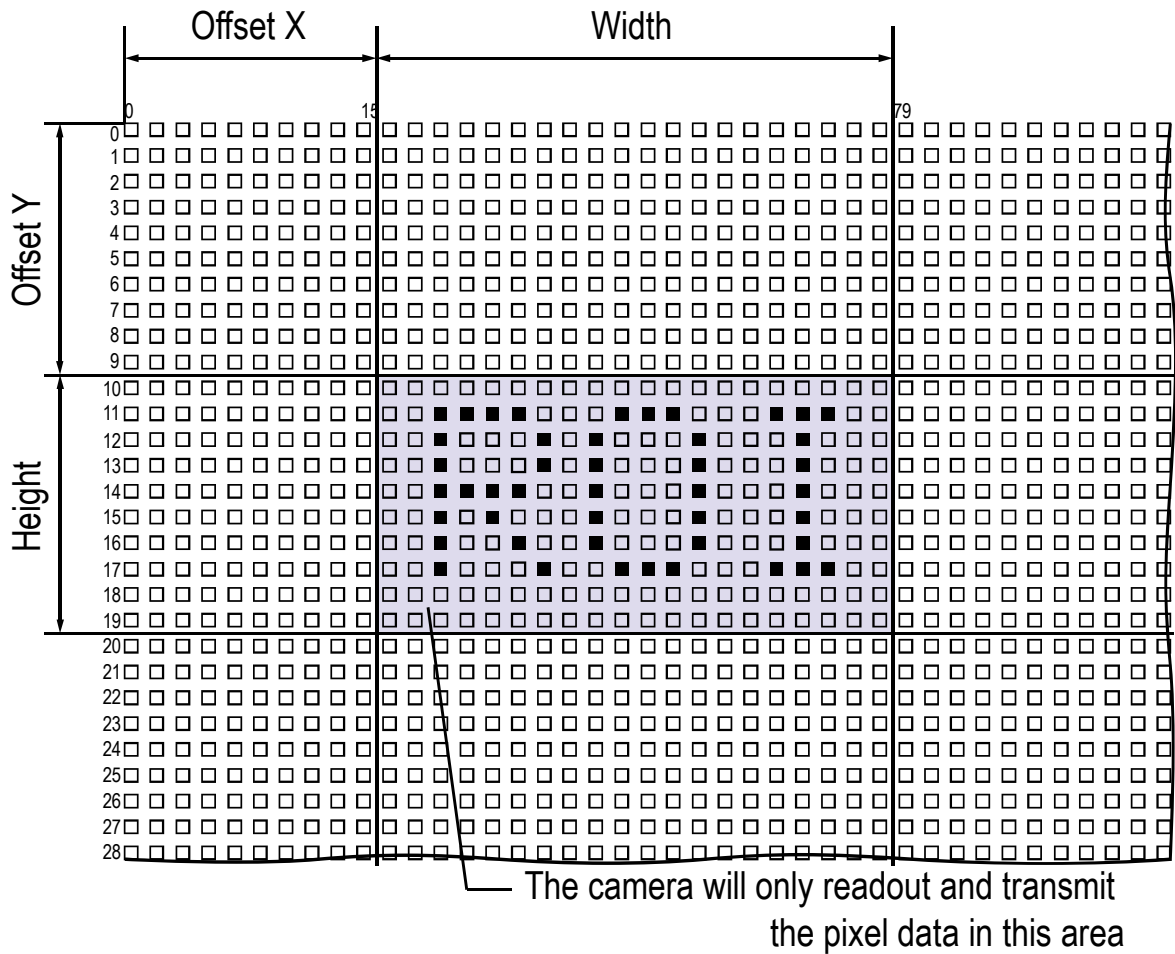

Figure 9-2 Region of Interest

The XML parameters related to ROI settings are as follows.

XML Parameters	Value	Description	
ImageFormatControl	SensorWidth ^a	-	Effective width of the sensor
	SensorHeight ^a	-	Effective height of the sensor
	WidthMax	-	Maximum allowed width of the image with the current camera settings
	HeightMax	-	Maximum allowed height of the image with the current camera settings
	Width ^b	-	Sets the Width of the Image ROI.
	Height ^b	-	Sets the Height of the Image ROI.
	OffsetX ^c	-	Sets the horizontal offset from the origin to the Image ROI.
	OffsetY ^c	-	Sets the vertical offset from the origin to the Image ROI.

The unit for all parameters in this table is pixel.

a: Read only. User cannot change the value.

b: User configurable parameters for setting ROI

c: User configurable parameters for setting the origin of the ROI

Table 9-1 XML Parameters related to ROI

You can change the size of ROI by setting the **Width** and **Height** parameters in the **Image Format Control** category. You can also change the position of the ROI origin by setting the **Offset X** and **Offset Y** parameters. Make sure that the **Width + Offset X** value is less than the **Width Max** value, and the **Height + Offset Y** value is less than the **Height Max** value. You must set the size of the ROI first, and then set the Offset values since the **Width** and **Height** parameters are set to its maximum value by default.

- On the VP-103MX2-M/C24I camera, the **Width** parameter must be set to a multiple of 16, and the **Height** parameter must be set to a multiple of 2.

The minimum allowed setting values for the ROI Width and Height are shown below.

Camera Model	Minimum Width Settings	Minimum Height Settings
VP-103MX2-M/C24I	16	4

Table 9-2 Minimum ROI Width and Height Settings

On the VP-103MX2-M/C24I camera, the maximum allowed frame rates depending on Horizontal and Vertical ROI changes are shown below. The maximum allowed frame rates shown below are based on 8 bit Pixel Format, the frame rates get about 20% faster usually when the Pixel Format changes from 10 bit to 8 bit. However, the frame rate doesn't get faster if it already reaches the maximum frame rate of the sensor output.

ROI Size (H × V)	1 Channel	2 Channels	4 Channels
11264 × 4	196.2 fps	391.2 fps	785.7 fps
11264 × 1000	42.7 fps	85.3 fps	170.4 fps
11264 × 3000	16.5 fps	33.1 fps	66.2 fps
11264 × 5000	10.3 fps	20.5 fps	41.1 fps
11264 × 7000	7.4 fps	14.9 fps	29.8 fps
64 × 9200	24.7 fps	24.7 fps	24.7 fps
1008 × 9200	24.7 fps	24.7 fps	24.7 fps
2000 × 9200	24.7 fps	24.7 fps	24.7 fps
3008 × 9200	21.2 fps	24.7 fps	24.7 fps
5008 × 9200	12.8 fps	24.7 fps	24.7 fps
7008 × 9200	9.2 fps	18.3 fps	24.7 fps
11264 × 9200	5.7 fps	11.4 fps	22.8 fps

Table 9-3 Maximum Frame Rates by VP-103MX2-M/C24I ROI Changes_CXP-6

ROI Size (H × V)	1 Channel	2 Channels	4 Channels
11264 × 4	313.3 fps	623.4 fps	850.2 fps
11264 × 1000	68.2 fps	136.4 fps	184.4 fps
11264 × 3000	26.5 fps	53.0 fps	71.7 fps
11264 × 5000	16.4 fps	32.9 fps	44.5 fps
11264 × 7000	11.9 fps	23.8 fps	24.7 fps
64 × 9200	24.7 fps	24.7 fps	24.7 fps
1008 × 9200	24.7 fps	24.7 fps	24.7 fps
2000 × 9200	24.7 fps	24.7 fps	24.7 fps
3008 × 9200	24.7 fps	24.7 fps	24.7 fps
5008 × 9200	20.4 fps	24.7 fps	24.7 fps
7008 × 9200	14.7 fps	24.7 fps	24.7 fps
11264 × 9200	9.1 fps	18.3 fps	24.7 fps

Table 9-4 Maximum Frame Rates by VP-103MX2-M/C24I ROI Changes_CXP-10

ROI Size (H × V)	1 Channel	2 Channels	4 Channels
11264 × 4	391.2 fps	785.7 fps	850.2 fps
11264 × 1000	85.3 fps	170.4 fps	184.4 fps
11264 × 3000	33.1 fps	66.2 fps	71.7 fps
11264 × 5000	20.5 fps	41.1 fps	44.5 fps
11264 × 7000	14.9 fps	29.8 fps	32.2 fps
64 × 9200	24.7 fps	24.7 fps	32.2 fps
1008 × 9200	24.7 fps	24.7 fps	24.7 fps
2000 × 9200	24.7 fps	24.7 fps	24.7 fps
3008 × 9200	24.7 fps	24.7 fps	24.7 fps
5008 × 9200	24.7 fps	24.7 fps	24.7 fps
7008 × 9200	18.3 fps	24.7 fps	24.7 fps
11264 × 9200	11.46 fps	22.8 fps	24.7 fps

Table 9-5 Maximum Frame Rates by VP-103MX2-M/C24I ROI Changes_CXP-12



Caution!

Your CXP-12 Frame Grabber may place additional restrictions on how the ROI location and size must be set. Refer to your CXP-12 Frame Grabber user manual for more information.

9.3 Multi-ROI

The VP-103MX2-M/C24I camera provides the Multi-ROI feature which allows you to define up to 32 regions of the sensor array. When an image is acquired, only the pixel information from the defined regions will be readout of the sensor. The pixel data read out of the regions will then be combined together and will be transmitted from the camera as a single image.

The XML parameters related to Multi-ROI are as follows.

XML Parameters		Value †	Description
MultiRoiControl	MultiRoiSelector	Region0 - Region31	Selects the ROI to set
	MultiRoiMode	On/Off	Enables/Disables the selected ROI
	MultiRoiWidth	64 - 11264	Width setting for the selected ROI
	MultiRoiHeight	4 - 9200	Height setting for the selected ROI
	MultiRoiOffsetX	0 - 11264	Horizontal offset from the origin to the selected ROI
	MultiRoiOffsetY	0 - 9200	Vertical offset from the origin to the selected ROI
	MultiRoiValid ^a	-	Verifies the validation of the Multi-ROI setting values
	MultiRoiStatus	Active/Inactive	Displays the status of the Multi ROI feature Active: The Multi-ROI feature is in use Inactive: The Multi-ROI feature is not in use

†: The unit for all parameters in this table is pixel.

a: If the setting values for the Multi-ROI feature are valid, 'True' will be returned or the check box will be selected.

Table 9-6 XML parameters related to Multi-ROI

It is recommended that you first set the **MultiROIWidth** parameter, since all of the regions must be the same width. The next step in the setup process is to define each individual region as desired. Up to 31 regions can be set up ranging from 0 through 32. Use the **MultiROISelector** parameter to select which ROI to set and then set the ROI to On/Off by using the **MultiROIMode** parameter. Then, set the **MultiROIOffsetX**, **MultiROIOffsetY** and **MultiROIHeight** parameters to define each region.

In the figure below, for example, three regions have been set. With these settings, the camera would output an image as follows:

- MultiROI Width × the total height of the three regions (Region0 Height + Region1 Height + Region2 Height)

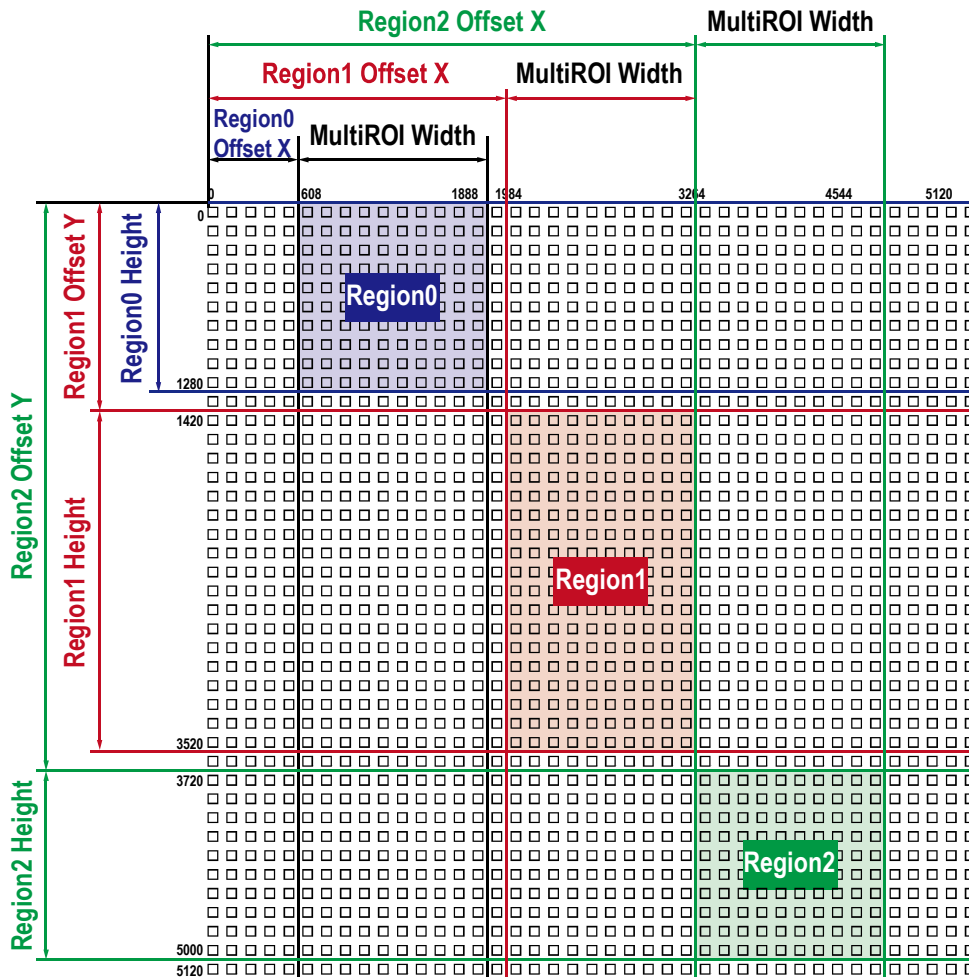

Figure 9-3 Multi-ROI

There are several things to keep in mind when setting the Multi-ROI feature on the VP-103MX2-M/C24I camera:

- The sum of the Multi-ROI Offset X value plus the Multi-ROI Width value must not exceed the Width value of the camera's sensor.
- The sum of the Multi-ROI Offset Y value plus the Multi-ROI Height value must not exceed the Height value of the camera's sensor.
- The Multi-ROI Offset X and Multi-ROI Width value must be a multiple of 16.
- The Multi-ROI Offset Y and Multi-ROI Height value must be a multiple of 2.
- The MultiROI Width values are equal, so the widths of the Region 0, Region 1, and Region 2 are the same in the figure above.
- You can save the Multi-ROI setting values as a User Set and then load the values to the camera when desired. For more information, refer to 9.30 User Set Control.

9.4 Binning

The Binning has the effects of increasing the level value and decreasing resolution by summing the values of the adjacent pixels and sending them as one pixel.

The XML parameters related to Binning are as follows.

XML Parameters	Value	Description	
ImageFormat Control	BinningSelector	Sensor	N/A
		Logic	Applies the Binning in digital by the logic.
	Binning HorizontalMode	Sum	Adds pixel values from the adjacent pixels as specified in the Binning Horizontal, and then sends them as one pixel.
		Average	Adds pixel values from the adjacent pixels as specified in the Binning Horizontal and divides them by the number of combined pixels, and then sends them as one pixel.
	BinningHorizontal	1×, 2×, 4×	The number of horizontal pixels to combine together. 4× is supported only for monochrome.
	Binning VerticalMode	Sum	Adds pixel values from the adjacent pixels as specified in the Binning Vertical, and then sends them as one pixel.
		Average	Adds pixel values from the adjacent pixels as specified in the Binning Vertical and divides them by the number of combined pixels, and then sends them as one pixel.
	BinningVertical	1×, 2×, 4×	The number of vertical pixels to combine together. 4× is supported only for monochrome.

Table 9-7 XML Parameters related to Binning

For example, if you set 2×2 binning, the camera's resolution is reduced to $1/4$. If you set the **Binning Mode** to **Sum**, the maximum allowed resolution of the image is reduced $1/2$ and the responsivity of the camera is quadrupled. If you set the **Binning Mode** to **Average**, the maximum allowed resolution of the image is reduced to $1/2$, but there is no difference in responsivity between a binned image and an original image. The **Width Max** and **Height Max** parameter, indicating the maximum allowed resolution of the image with the current camera settings, will be updated depending on the binning settings. And also, the **Width**, **Height**, **Offset X** and **Offset Y** parameters will be updated depending on the binning settings. You can verify the current resolution through the **Width** and **Height** parameters.

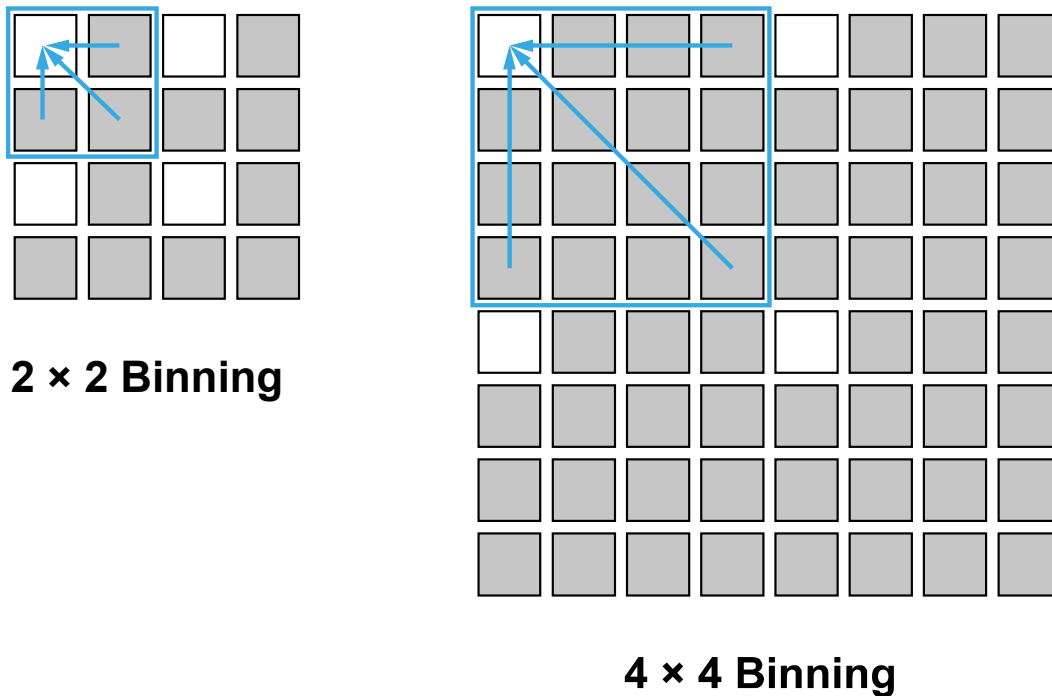

Figure 9-4 2×2 Binning and 4×4 Binning

9.5 CXP Link Configuration

The VP-103MX2-M/C24I camera must be connected to a CXP-12 Frame Grabber of CXP 2.0 interface. CoaXPress 2.0 interface allows you to connect a camera to a Frame Grabber supporting CXP 2.0 by using simple coax cabling and allows up to 12.5 Gbps data rate per cable. The VP-103MX2-M/C24I camera supports one master connection and up to three extension connections to configure a link. In compliance with the CoaXPress standard, the camera includes an automatic link detection mechanism (Plug and Play) to correctly detect the camera to CXP-12 Frame Grabber connections.

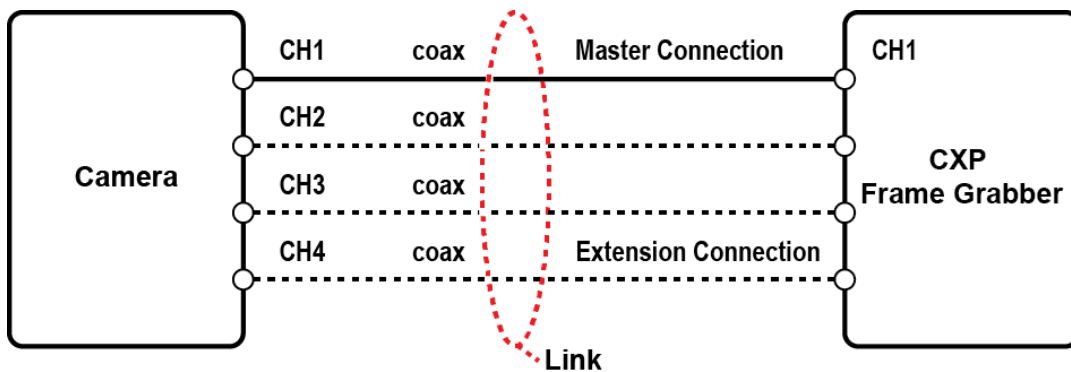

Figure 9-5 CXP Link Configuration

The XML parameters related to the link configuration between the camera and CXP-12 Frame Grabber are as follows.

XML Parameters	Value	Description
CoaXPress CxpLinkConfiguration Preferred	Read Only	Displays bit rate and the number of connections to be set for the link configuration between the camera and Host (Frame Grabber) while discovering devices. Saves the current CxpLinkConfiguration values as the CxpLinkConfigurationPreferred value when you execute the User Set Save parameter.
CxpLinkConfiguration	CXP6_X1 CXP6_X2 CXP6_X4 CXP10_X1 CXP10_X2 CXP10_X4 CXP12_X1 CXP12_X2 CXP12_X4	Sets bit rate and the number of connections for the link configuration. e.g. CXP12_X4: Four connections running at a maximum of CXP12 speed (12.5 Gbps)

Table 9-8 XML Parameters related to CXP Link Configuration

9.6 Pixel Format

The VP-103MX2-M/C24I camera processes image data in the unit of 12 bit. The pixel format of the image data is available to be chosen among 8 bit, 10 bit, or 12 bit with the Pixel Format parameter. For instance, the 2 least significant bits will be dropped from overall 10 bits when the camera is set for 10-bit pixel format.

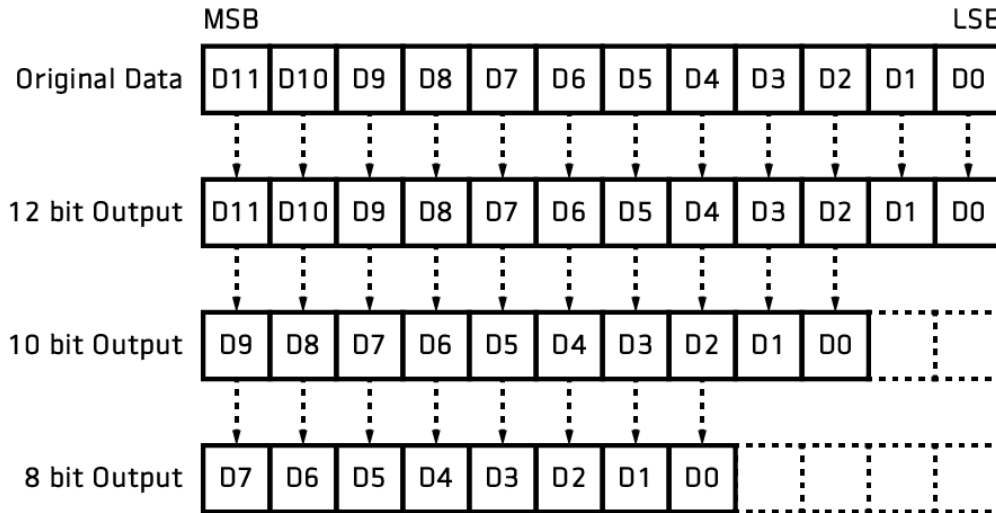

Figure 9-6 VP-103MX2-M/C24I Pixel Format

The XML parameter related to Pixel Format is as follows.

XML Parameter	Description
ImageFormatContro l	PixelFormat Sets the pixel format supported by the device.

Table 9-9 XML Parameter related to Pixel Format

The available pixel formats on the monochrome and color cameras are as follows.

Mono Sensor	Color Sensor
Mono 8	Mono 8
Mono 10	Mono 10
Mono 12	Mono 12
	Bayer GB 8
	Bayer GB 10
	Bayer GB 12

Table 9-10 Pixel Format Values

9.7 Data ROI (Color Only)

The Balance White Auto feature provided by the color camera uses the pixel data from a Data Region of Interest (ROI) to adjust the related parameters. The XML parameters related to Data ROI are as follows.

XML Parameters	Value	Description
DataRoiControl	RoiSelector	WhiteBalanceAuto
	RoiOffsetX	-
	RoiOffsetY	-
	RoiWidth	16 - 11264
	RoiHeight	2 - 9200

Table 9-11 XML Parameters related to Data ROI

Only the pixel data from the area of overlap between the Data ROI and the Image ROI by your settings will be effective if you use the Image ROI and Data ROI at the same time. The effective ROI is determined as shown in the figure below.

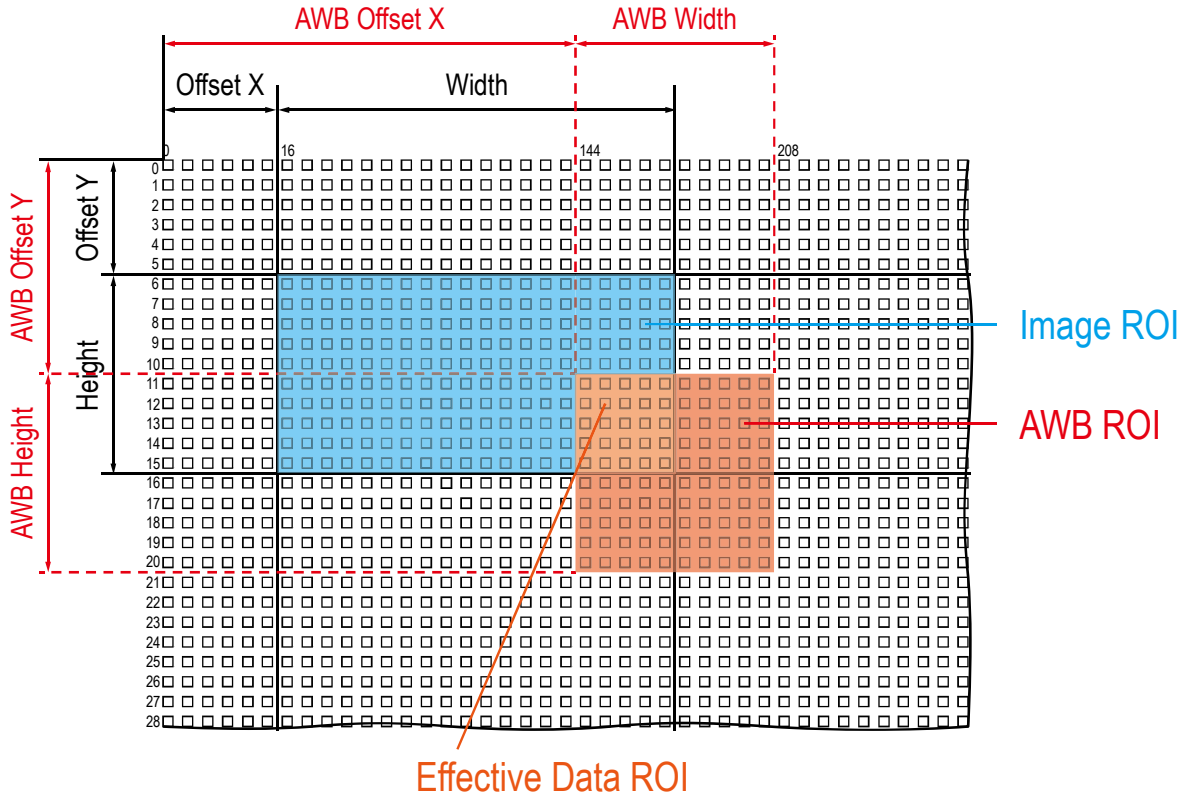

Figure 9-7 Effective Data ROI

9.8 White Balance (Color Only)

The color camera includes the white balance capability to adjust the color balance of the images transmitted from the camera. With the white balancing scheme used on the VC-25MC-31 I camera, the Red, Green and Blue intensities can be adjusted individually. You can set the intensity of each color by using the **Balance Ratio** parameter. The Balance Ratio value can range from 1.0 to 4.0. If the **Balance Ratio** parameter is set to 1.0 for a color, the intensity of the color will be unaffected by the white balance mechanism. If the **Balance Ratio** parameter is set to greater than 1.0, the intensity of the color will be proportionally increased to the ratio. For example, if the **Balance Ratio** is set to 1.5, the intensity of that color will be increased by 50%.

The XML parameters related to White Balance are as follows.

XML Parameters		Value	Description
AnalogControl	BalanceRatio Selector	Red	A Balance Ratio value will be applied to red pixels.
		Green	A Balance Ratio value will be applied to green pixels.
		Blue	A Balance Ratio value will be applied to blue pixels.
	BalanceRatio	×1.0 ~ ×4.0	Adjusts the ratio of the selected color.

Table 9-12 XML Parameters related to White Balance

9.8.1 Balance White Auto

The Balance White Auto feature is implemented on the color camera. It will control the white balance of the image acquired from the color camera according to the GreyWorld algorithm. Before using the Balance White Auto feature, you need to set the Data ROI for Balance White Auto. If you do not set the related Data ROI, the pixel data from the Image ROI will be used to control the white balance. As soon as the **Balance White Auto** parameter is set to **Once**, the Balance Ratio values for Red and Blue will be automatically adjusted to adjust the white balance by referring to Green.

The XML parameters related to Balance White Auto are as follows.

XML Parameter		Value	Description
AnalogControl	BalanceWhite Auto	Off	Balance White Auto Off
		Once	White Balance is adjusted once and then Off.

Table 9-13 XML Parameter related to Balance White Auto

9.9 Gain

Increasing the **Gain** parameter increases all pixel values of the image. This results in a higher grey value output from the camera for a given amount of output from the image sensor.

1. Selects the Gain Control (Analog All, Digital All) to be adjusted by using the Gain Selector parameter.
2. Sets the Gain parameter to the desired value.

The XML parameters related to Gain are as follows.

XML Parameters		Value	Description
Analog Control	GainSelector	Analog All	Applies the Gain value to all analog channels.
		Digital All	Applies the Gain value to all digital channels.
	Gain	1.4x – 5.2x	Sets an analog gain value.
		1.0x – 32.0x	Sets a digital gain value.

Table 9-14 XML Parameters related to Gain

9.10 Black Level and Optical Black Correction

The VP-103MX2-M/C24I camera offers the Optical Black Correction feature that adjusts the Black Level value into 0 automatically depending on a sensor. With this feature, good levels of images are easy to be acquired regardless of sensor-specific factors, because the feature makes the sensor optimize the Black Level automatically.

To make a sensor optimize Black Level automatically to fit into the value 0, use the feature by activating the checkbox of the **OpticalBlackCorrection** parameter.

However, Black Level needs to be adjusted manually by a user in the following cases:

- Very bright environment
- Very long exposure time

In the cases above, adjusting the **BlackLevelOffset** parameter will result in an offset to the pixel values output from the camera. To adjust Black Level manually, use the following procedure:

1. First, configure the environment as follows:
 - No light the surroundings by blocking light
 - Darken a sensor by capping its camera with a plastic cap
 - Close an iris to the maximum
2. Deactivate the checkbox of the **OpticalBlackCorrection** parameter.
3. Choose **DigitalAll** on the **BlackLevelSelector** parameter.
4. Set the **BlackLevelOffset** value to the value of your wish by adjusting its slider bar.

To apply a positive number(from 0 to 64) to the **BlackLevelOffset** value, it is recommended to check if the **OpticalBlackCorrection** checkbox is deactivated. In case that the checkbox has been activated, inactivate the checkbox first, after that, control the **BlackLevelOffset** value.

5. Before set the **BlackLevel** value, refer to the sequence described in **Figure 9-8** below and finish the other necessary jobs related to acquired images.
6. Set the **BlackLevel** parameter as the necessary value. The range of the value varies with sensors or setting values of the **Pixel Format** parameters.

The figure below shows sequence of the signal processing related to Black Level, and the "Digital Offset" item indicates those related to Black Level. It is recommended to do the prior jobs such as DSNU or PRNU corrections, after then, to do the job related to Black Level.

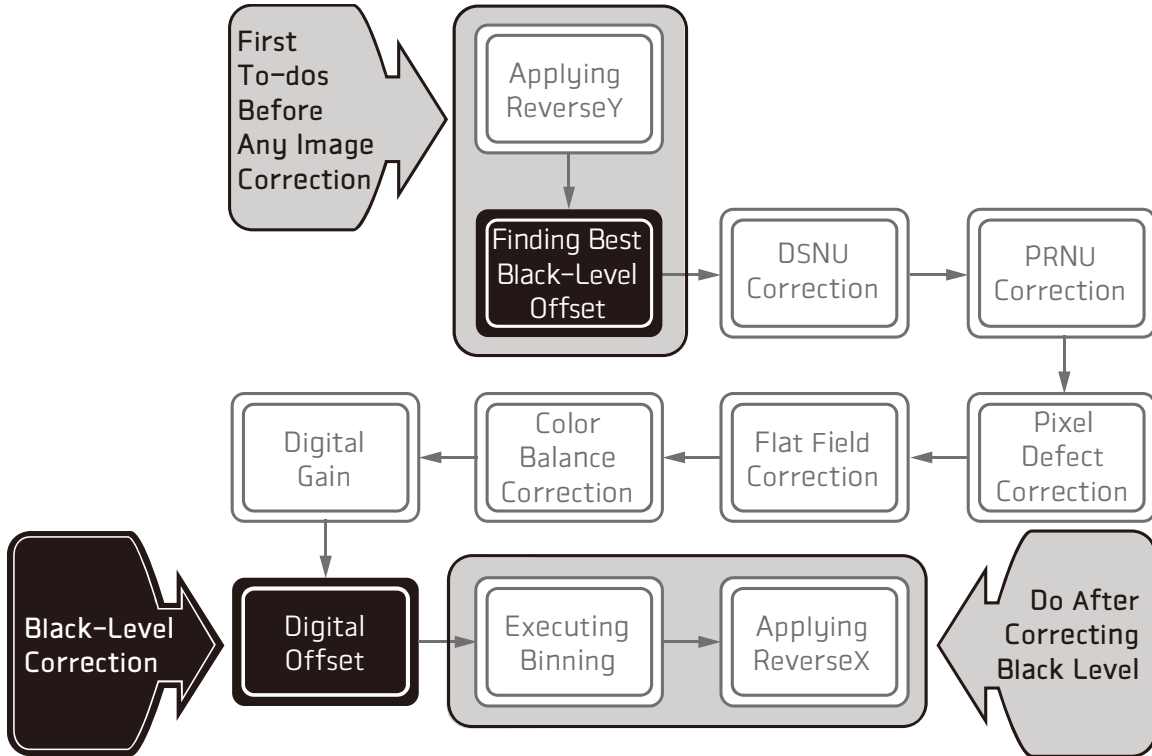

Figure 9-8 Sequence of signal processing and Black Level



System's sequence of the signal processing:

The product handles signals basically in the sequence described in Figure 9-8 above. For instance, no need to work again if you did the DSNU/PRNU correction or others prior to the Black Level job, however, it needs to be done again in the case that it was finished before the DSNU/PRUN correction or others.

The XML parameters related to Black Level are as follows.

XML Parameters		Value	Description
ImageFormat Control	OpticalBlack Correction	False	Changes into the mode available to adjust manually by a user.
		True	Changes into the mode available to optimize automatically by a sensor.
Analog Control	BlackLevelSelector	DigitalAll	Applies the Black Level value to all digital channels.
	BlackLevel	8 bit: 0 ~ 15.93 10 bit: 0 ~ 63.75 12 bit: 0 ~ 255.00	Sets a black level value.
	BlackLevelOffset	-64 ~ 64	Sets a value of Black Level manually.

Table 9-15 XML Parameters related to Black Level



Manual setting of the BlackLevelOffset value:

To adjust Black Level precisely and manually, first, deactivate the OpticalBlackCorrection feature and then input the BlackLevelOffset value. The value will not work although the value of the parameter is adjusted under the OpticalBlackCorrection feature has been activated.

9.11 Defective Pixel Correction

The CMOS sensor may have defect pixels which cannot properly react to the light. Correction is required since it may deteriorate the quality of output image. Defect pixel information of CMOS used for each camera is entered into the camera during the manufacturing process. If you want to add defect pixel information, it is required to enter coordinate of new defect pixel into the camera. For more information, refer to Appendix A.

9.11.1 Correction Method

A correction value for a defect pixel is calculated based on the valid pixel value adjacent in the same line.

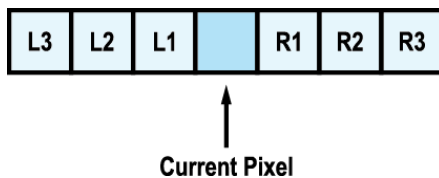

Figure 9-9 Location of Defect Pixel to be corrected

If the Current Pixel is a defect pixel as shown in the figure above, the correction value for this pixel is obtained as shown in the following table depending on whether surrounding pixels are defect pixels or not.

Adjacent Defect Pixel	Correction Value of Current Pixel
None	$(L1 + R1) / 2$
L1	R1
R1	L1
L1, R1	$(L2 + R2) / 2$
L1, R1, R2	L2
L2, L1, R1	R2
L2, L1, R1, R2	$(L3 + R3) / 2$
L2, L1, R1, R2, R3	L3
L3, L2, L1, R1, R2	R3

Table 9-16 Calculation of Defect Pixel Correction Value

9.12 Dark Signal Non-uniformity Correction

In theory, when a digital camera acquires images in complete darkness, all of the pixel values in the image should be near zero and they should be equal. In practice, however, slight variations in the performance of the pixels in the sensor will cause some variations in the pixel values output from the camera when the camera is acquiring in darkness. This variation is known as Dark Signal Non-uniformity (DSNU). The VP-103MX2-M/C24I cameras provide the DSNU Correction feature.

The XML parameters related to DSNU are as follows.

XML Parameters	Value	Description	
DSNU	DSNUDataSelector	Default	Selects Default as a non-volatile memory location to load DSNU data from.
		Space1 - 3	Selects a user defined location as a non-volatile memory location to save DSNU data to or load DSNU data from.
	DSNUDataGenerate	-	Generates the DSNU data for the current camera settings.
	DSNUDataSave	-	Saves the generated DSNU data in the non-volatile memory. The generated data by executing the DSNUDataGenerate command are saved in the volatile memory so that the data are lost if the camera is reset or if power is turned off. To use the data after the camera is powered on or reset, save them in the non-volatile memory.
	DSNUDataLoad	-	Loads the DSNU data from the non-volatile memory into the volatile memory.

Table 9-17 XML Parameters related to DSNU

9.12.1 Generating and Saving User DSNU Correction Values

To generate and save user DSNU correction values, use the following procedure.



Note:

- For optimum DSNU correction results, we recommend that you generate DSNU data after the temperature of the camera housing has been stabilized.
 - Before generating DSNU data, set the FFC feature to Off.
-

1. To obtain the optimum DSNU correction values, set the ROI to the actual settings you will be using during normal operation.
2. Ensure that the camera will be acquiring images in complete darkness by covering the camera lens, closing the iris in the lens, or darkening the room.
3. Begin acquiring images by setting the camera for the Free-Run mode.
4. Execute the **DSNU Data Generate** command to generate DSNU data for the current camera settings.
5. The generated DSNU correction values will be activated and saved in the camera's volatile memory.
6. To save the generated DSNU correction values in the camera's Flash (non-volatile) memory, use the **DSNU Data Selector** parameter to specify a location to save the DSNU correction values, and then execute the **DSNU Data Save** command. The previous DSNU values saved in the memory will be overwritten.

To disregard the generated DSNU correction values and load the existing values in the Flash memory, use the **DSNU Data Selector** parameter to select a desired DSNU correction values, and then execute the **DSNU Data Load** command.

9.13 Photo Response Non-uniformity Correction

In theory, when a line scan camera acquires images with the camera viewing a uniform light-colored target in bright light, all of the pixel values in the image should be near the maximum grey value and they should be equal. In practice, however, slight variations in the performance of the pixels in the sensor, variations in the optics, and variations in the lighting will cause some variations in the pixel values output from the camera. This variation is known as Photo Response Non-uniformity (PRNU). The VP-103MX2-M/C24I cameras provide the PRNU Correction feature.

The XML parameters related to PRNU are as follows.

XML Parameters	Value	Description	
PRNU	PRNUNUDataSelector	Default	Selects Default as a non-volatile memory location to load PRNU data from.
		Space1 - 3	Selects a user defined location as a non-volatile memory location to save PRNU data to or load PRNU data from.
	PRNUDataGenerate	-	Generates the PRNU data for the current camera settings.
	PRNUDataSave	-	Saves the generated PRNU data in the non-volatile memory. The generated data by executing the PRNUDataGenerate command are saved in the volatile memory so that the data are lost if the camera is reset or if power is turned off. To use the data after the camera is powered on or reset, save them in the non-volatile memory.
	PRNUDataLoad	-	Loads the PRNU data from the non-volatile memory into the volatile memory.

Table 9-18 XML Parameters related to PRNU

9.13.1 Generating and Saving User PRNU Correction Values

To generate and save user PRNU correction values, use the following procedure.



Note:

To generate the optimum PRNU data,

- we recommend that you generate DSNU correction values first before generating PRNU correction values.
- set the FFC feature to Off before generating PRNU correction values.
- the grey reference image must be acquired at uniform illumination. We strongly recommend that you use a high-quality light source to deliver uniform illumination. Standard illumination may not be appropriate.

The PRNU correction values stored in Default are optimized for use in typical situations and will provide good camera performance in most cases. Use of the values stored in Default is recommended.

1. To generate PRNU correction values suitable for your operating conditions, set the ROI to the actual settings you will be using during normal operation. We strongly recommend that you use the Default PRNU correction values stored in Default, if you cannot set up the uniform illumination.
2. Without mounting a lens on the camera, place a uniform illumination (e.g. backlight) in the field of view of the camera. Set up the camera as you would for normal operation. We recommend that you make adjustments to achieve the digital output level in a range from 150 to 200 (Gain: 1.00 at 8 bit).
3. Begin acquiring images by setting the camera for the Free-Run mode.
4. Execute the **PRNU Data Generate** command to generate PRNU correction values for the current camera settings.
5. The generated PRNU correction values will be activated and saved in the camera's volatile memory.
6. To save the generated PRNU correction values in the camera's Flash (non-volatile) memory, use the **PRNU Data Selector** parameter to specify a location to save the PRNU correction values, and then execute the **PRNU Data Save** command. The previous PRNU values saved in the memory will be overwritten.

To disregard the generated PRNU correction values and load the existing values in the Flash memory, use the **PRNU Data Selector** parameter to select a desired PRNU correction values, and then execute the **PRNU Data Load** command.

9.14 Flat Field Correction

The Flat Field Correction feature improves the image uniformity when you acquire a non-uniformity image due to external conditions. The Flat Field Correction feature of the VP-103MX2-M/C24I camera can be summarized by the following equation.

$$IC = IR / IF$$

IC: Level value of corrected image

IR: Level value of original image

IF: Level value of Flat Field data

In actual use conditions, generate a Flat Field correction data and then save the data into the non-volatile memory of the camera by following the procedure below.

1. Execute the **Flat Field Data Generate** parameter.

After executing the **Flat Field Data Generate** parameter, you must acquire one image to generate the scaled down Flat Field correction data.

2. Use the **Flat Field Data Selector** parameter to specify a location to save the generated Flat Field correction data.
3. Execute the **Flat Field Data Save** parameter to save the generated Flat Field data into the non-volatile memory. When the scaled down Flat Field data are used for correction, they are expanded and applied with a Bilinear Interpolation as shown in the **Figure 9-11**.

To disregard the generated Flat Field correction data and load the existing Flat Field correction data, execute the **Flat Field Data Load** parameter before executing the **Flat Field Data Save** parameter.

4. Set the **Flat Field Correction** parameter to **On** to apply the Flat Field data to the camera.



Caution!

- It is recommended that you enable the Defective Pixel Correction feature before executing the Flat Field Data Generate parameter.
- Before executing the Flat Field Data Generate parameter, you must set the camera as follows:
OffsetX, Y: 0
Width, Height: Maximum values
- After executing the Acquisition Start command, you need to operate the camera with the free-run mode or apply a trigger signal to acquire an image.

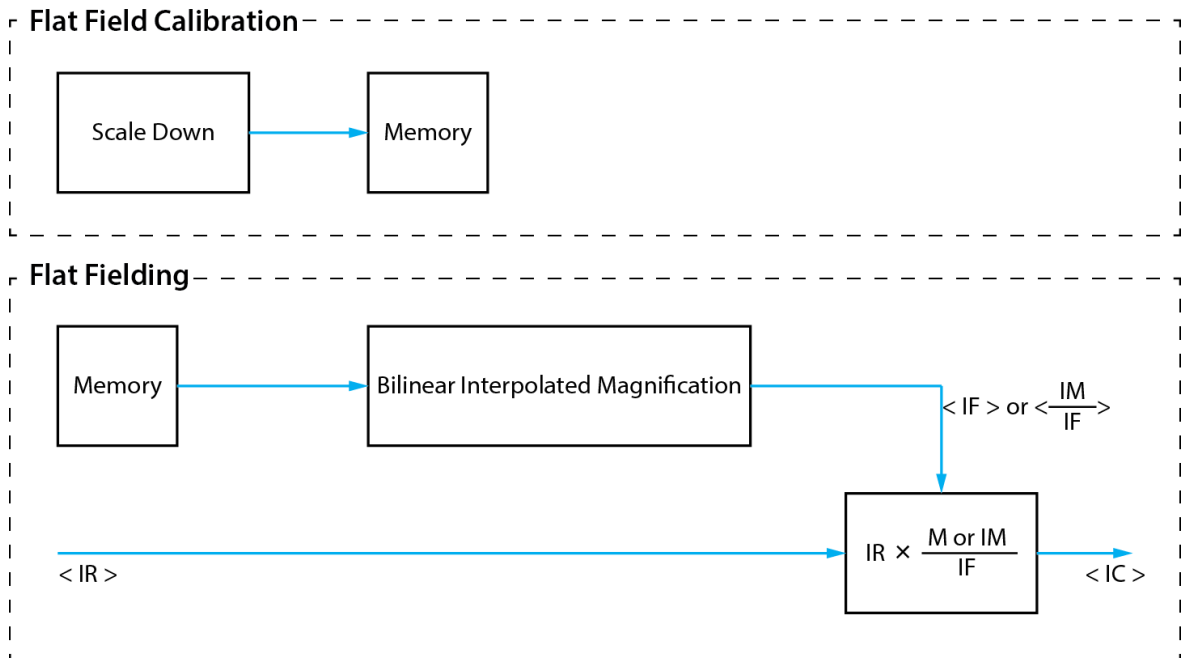

Figure 9-10 Generation and Application of Flat Field Data

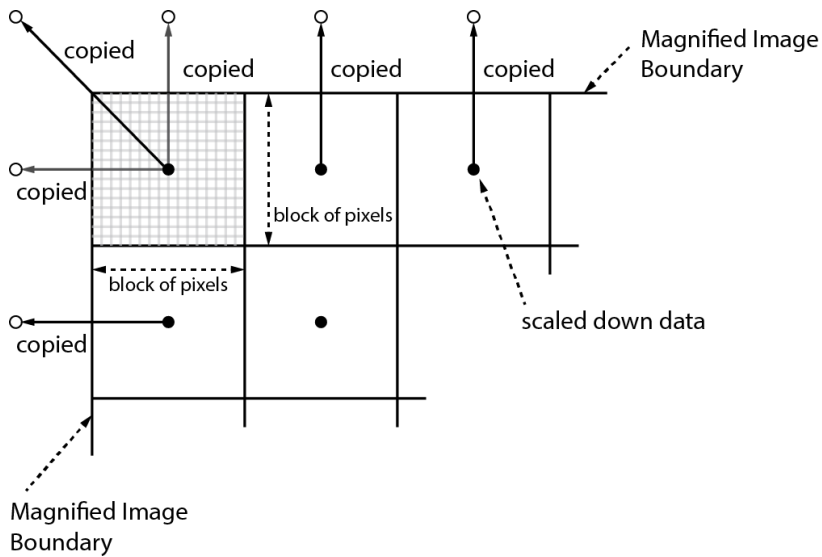

Figure 9-11 Bilinear Interpolated Magnification

The XML parameters related to Flat Field Correction are as follows.

XML Parameters		Value	Description
FlatFieldControl	FlatFieldCorrection	Off	Disables the Flat Field Correction feature.
		On	Enables the Flat Field Correction feature.
	FlatFieldData Selector	Space0 - Space15	Selects a location to save Flat Field data to or load Flat Field data from. Space0~Space15:User defined location
	FlatFieldTargetSelector	Auto	Auto-adjusts the target value of the image after correction.
		User Set	Manually sets the target value of the image after correction.
	FlatFieldTargetLevel	8bit: 1-255 12bit: 1 – 4095	Sets the target value of the image after correction when Flat Field Target Selector is set to User Set. <ul style="list-style-type: none"> The setting range is based on the 12-bit Pixel Format.
	FlatFieldData Generate	-	Generates the Flat Field data.
	FlatFieldDataSave	-	Saves the generated Flat Field correction data in the non-volatile memory. The data generated by executing the Flat Field Data Generate parameter are saved in the volatile memory so that the data are lost if the camera is reset or if power is turned off. To use the data after the camera is powered on or reset, save them in the non-volatile memory.
FlatFieldDataLoad	-	Loads the Flat Field data from the non-volatile memory into volatile memory.	

Table 9-19 XML Parameters related to Flat Field Correction

9.14.1 Flat Field Data Selector

As mentioned above, the generated Flat Field correction data are stored in the camera's volatile memory and the data are lost if the camera is reset or powered off. To use the generated Flat Field correction data after the camera is powered on or reset, you need to save them in the camera's non-volatile memory. The VP-103MX2-M/C24I camera provides thirty-two reserved locations in the camera's non-volatile memory available for saving and loading the Flat Field correction data. You can use the Flat Field Data Selector parameter to select a location as desired.

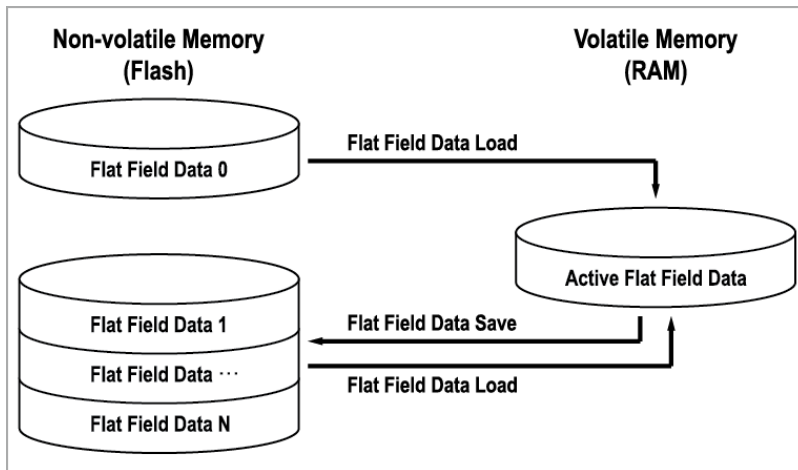

Figure 9-12 Flat Field Data Selector

Saving Flat Field Data

In order to save the active Flat Field data into a reserved location in the camera's Flash memory, follow the procedure below.

1. Use the Flat Field Data Selector parameter to specify a location to save the active Flat Field data.
2. Execute the Flat Field Data Save parameter to save the active Flat Field data to the selected location.

Loading Flat Field Data

If you saved Flat Field correction data into the camera's non-volatile memory, you could load the saved Flat Field correction data from the camera's non-volatile memory into the camera's active Flat Field data location.

1. Use the **Flat Field Data Selector** parameter to specify a reserved location whose Flat Field correction data will be loaded into the camera's active Flat Field data location.
2. Execute the **Flat Field Data Load** parameter to load the selected Flat Field correction data into the active Flat Field data location.

9.15 Timestamp

VP-103MX2-M/C24I camera provides a Timestamp feature.

XML parameters related to Timestamp are as follows.

XML Parameters		Description
DeviceControl	Timestamp	Indicates the current Timestamp value of the connected device.
	TimestampIncrement	Indicates the increment of Timestamp.
	TimestampReset	Changes the current Timestamp value into 0 and restarts counting.
	TimestampResetValue	Designates time to reset Timestamp as 0, by the form in the numeric value.
	TimestampLatch	Latches the current value of Timestamp.
	TimestampLatchValue	Indicates prior value before resetting the Timestamp value.

Table 9-20 XML Parameters related to Timestamp

9.16 Event Control

VP-103MX2-M/C24I camera provides an Event Notification feature. With the Event Notification feature, the camera can generate an event and transmit a related event message to the PC whenever a specific situation has occurred.

The VP-103MX2-M/C24I camera can generate and transmit events for the following type of situation:

- When the TestEventGenerate parameter is executed (Test)

XML parameters related to Event Control are as follows.

XML Parameters	Value	Description	
EventControl	EventSelector	Test	Transfers the Test event generated from the execution of the TestEventGenerate parameter.
	Event Notification	On	Enables the selected event notification.
		Off	Disables the selected event notification.
TestControl	TestPendingAck	-	Sets time to wait before writing the device's pending acknowledge feature.
	TestEventGenerate	-	Generates a Test event.

Table 9-21 XML Parameters related to Event Control

9.17 Digital I/O Control

The Control I/O receptacle of the camera can be operated in various modes.

The XML parameters related to Digital I/O Control are as follows.

XML Parameters	Value	Description	
DigitalIOControl	LineSelector	Line0	Configures the items related to the pins of No.2 and No.3 among 6 of the pins.
		Line1	Configures the items related to the pin No.4 among 6 of the pins.
	LineMode	Input	Appears under Line0 is chosen.
		Output	Appears under Line1 is chosen.
	LineInverter	FALSE	Disables inversion on the output signal of the line.
		TRUE	Enables inversion on the output signal of the line.
	LineSource	Off	Disables the line output.
		Exposure Active	Outputs pulse signals indicating the current exposure time.
		Frame Active	Outputs pulse signals indicating a frame readout time.
		UserOutput0	Outputs pulse signals set by User Output Value.
		Timer0 Active	Outputs user-defined Timer signals as pulse signals.
	UserOutput Selector	UserOutput0	Outputs pulse signals set by User Output Value.
	UserOutput Value	FALSE	Sets the bit state of the line to Low.
		TRUE	Sets the bit state of the line to High.
	Debounce Time	0 ~ 1,000,000	Sets a Debounce Time in microseconds (Default: 0.5 μ s).

Table 9-22 XML Parameters related to Digital I/O Control

When you set the Line Source to UserOutput0, you can use the user setting values as output signals.

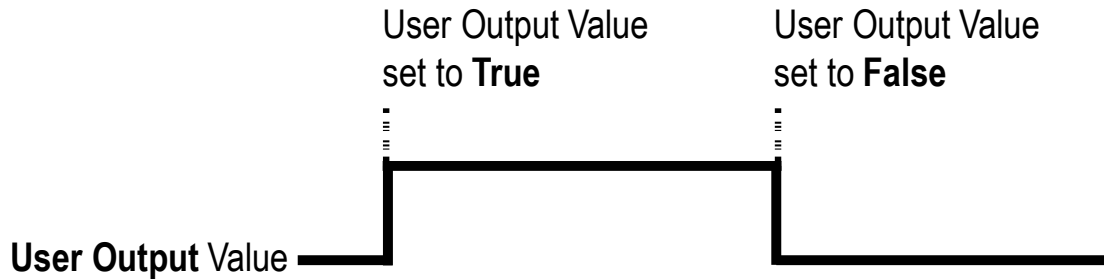

Figure 9-13 User Output

The camera can provide an Exposure Active output signal. The signal goes high when the exposure time for each frame acquisition begins and goes low when the exposure time ends as shown in the figure below. This signal can be used as a flash trigger and is also useful when you are operating a system where either the camera or the object being imaged is movable. Typically, you do not want the camera to move during exposure. You can monitor the Exposure Active signal to know when exposure is taking place and thus know when to avoid moving the camera.

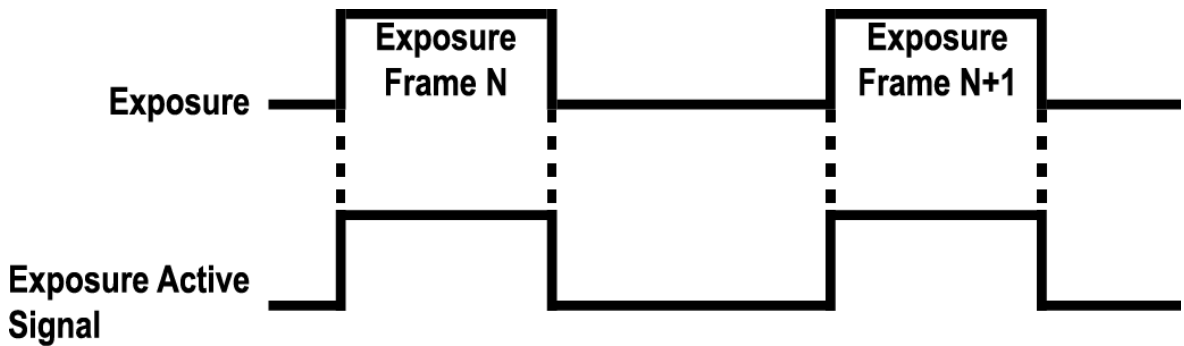

Figure 9-14 Exposure Active Signal

9.18 Debounce

The Debounce feature of the VP-103MX2-M/C24I cameras allows to supply only valid signals to the camera by discriminating between valid and invalid input signals. The Debounce Time parameter specifies the minimum time that an input signal must remain High or Low in order to be considered as a valid input signal. When you use the Debounce feature, be aware that there is a delay between the point where the valid input signal arrives and the point where the signal becomes effective. The duration of the delay is determined by the Debounce Time parameter setting value.

When you set the Debounce Time parameter, High and Low signals shorter than the setting value are considered invalid and ignored as shown in the figure below.

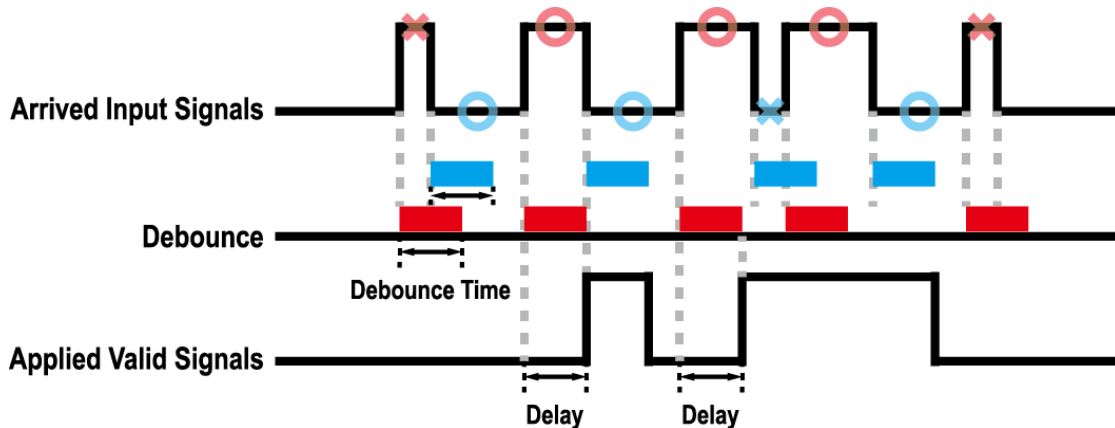

Figure 9-15 Debounce

The XML parameter related to Debounce Time is as follows.

XML Parameters	Value	Description
DigitalIOControl Debounce Time	0 – 1,000,000 μ s	Sets a Debounce Time in microseconds (Default: 0.5 μ s).

Table 9-23 XML Parameter related to Debounce Time

9.19 Timer Control

When the Line Source parameter is set to `Timer0Active`, the camera can provide output signals by using the Timer. On the VP-103MX2-M/C24I camera, the Frame Active, Exposure Active event or external trigger signal is available as Timer source signal.

The XML parameters related to Timer are as follows.

XML Parameters	Value	Description	
CounterAnd TimerControl	TimerSelector	Timer0	Selects a Timer to configure.
	TimerDuration	1 - 60,000,000 μ s	Sets the duration of the Timer output signal to be used when Timer Trigger Activation is set to Rising/Falling Edge.
	TimerDelay	0 - 60,000,000 μ s	Sets the delay time to be applied before starting the Timer.
	TimerReset	-	Resets the Timer and starts it again.
	TimerValue	-	Displays the current value of the selected Timer.
	TimerStatus	TimerIdle	Indicates that the Timer is in idle state.
		TimerTriggerWait	Indicates that the Timer is waiting for a trigger signal.
		TimerActive	Indicates that the Timer is in active state.
	TimerTrigger Source	Off	Disables the Timer trigger.
		ExposureActive	Sets the Timer to use the current exposure time as the source signal.
FrameActive		Sets the Timer to use a frame readout time as the source signal.	
Line0		Sets the Timer to use the external trigger signal as the source signal.	
TimerTrigger Activation	RisingEdge	Specifies that a rising edge of the selected trigger signal will act as the Timer trigger.	
	FallingEdge	Specifies that a falling edge of the selected trigger signal will act as the Timer trigger.	
	AnyEdge	Specifies that a rising edge or a falling edge of the selected trigger signal will act as the Timer trigger.	
	LevelHigh	Specifies that the Timer output signal will be valid as long as the selected trigger signal is High.	
	LevelLow	Specifies that the Timer output signal will be valid as long as the selected trigger signal is Low.	

Table 9-24 XML Parameters related to Timer Control

For example, when the Timer Trigger Source is set to Exposure Active and the Timer Trigger Activation is set to Level High, the Timer will act as follows.

1. When the source signals set by the Timer Trigger Source parameter are applied, the Timer will start operations.
2. The delay set by the Timer Delay parameter begins to expire.
3. When the delay expires, the Timer signal goes high as long as the source signal is high.

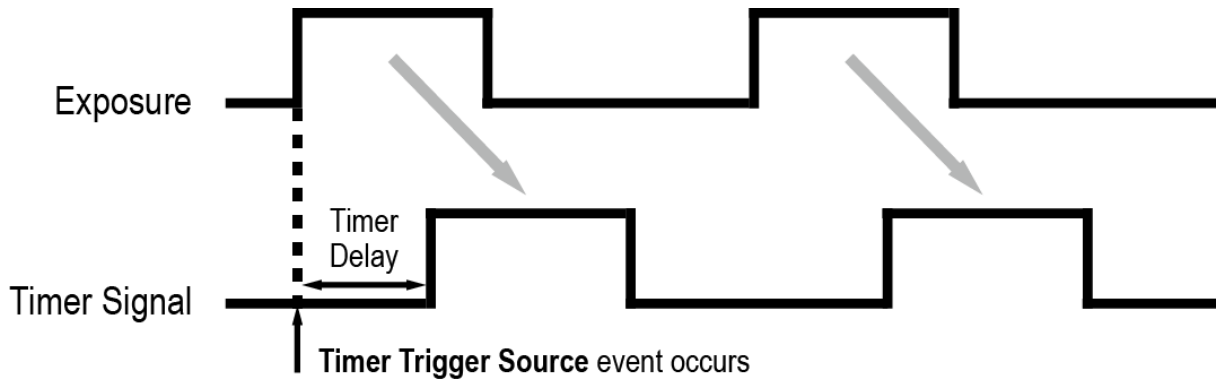

* **Timer Trigger Activation** is set to **Level High**.

Figure 9-16 Timer Signal

9.20 Cooling Control

A fan is installed on the rear panel of the camera to radiate heat. You can set the fan to turn on or off. You can also set the fan to turn on when a specified internal temperature is reached.

The XML parameters related to Cooling Control are as follows.

XML Parameters	Value	Description
CoolingControl	TargetTemperature	-10°C ~ 80°C Turns on the fan automatically when the temperature set in this parameter.
	FanOperationMode	Off On Turns off the fan. Turns on the fan.
	FanSpeed	- Displays the current Fan RPM.
	PeltierOperationMode	Off On Turns off the Thermoelectric Peltier. Turns on the Thermoelectric Peltier when the internal temperature exceeds the value set in the Target Temperature parameter.

Table 9-25 XML Parameters related to Cooling Control

9.21 Temperature Monitor

The camera has an embedded sensor chip to monitor the internal temperature.

The XML parameters related to Device Temperature are as follows.

XML Parameters		Value	Description
DeviceControl	DeviceTemperatureSelector	Mainboard	Sets a temperature measuring spot to the mainboard.
	DeviceTemperature	-	Displays device temperature in Celsius.

Table 9-26 XML Parameters related to Device Temperature

9.22 Status LED

A LED is installed on the rear panel of the camera to inform the operation status of the camera.

LED status and corresponding camera status are as follows:

Status LED	Description
Steady Red	The camera is not initialized.
Slow Flashing Red	A CXP Link is not configured.
Fast Flashing Orange	The camera is checking a CXP Link configuration.
Steady Green	A CXP Link is configured.
Fast Flashing Green	The camera is transmitting image data.

Table 9-27 Status LED

9.23 Test Pattern

To check whether the camera operates normally or not, it can be set to output test patterns generated in the camera, instead of image data from the image sensor. Four types of test patterns are available; images with different values in horizontal direction (Grey Horizontal Ramp), images with different values in diagonal direction (Grey Diagonal Ramp), moving images with different values in diagonal direction (Grey Diagonal Ramp Moving) and images with different values in horizontal direction output from the image sensor (Sensor Specific).

The XML parameter related to Test Pattern is as follows.

XML Parameter		Value	Description
ImageFormat Control	TestPattern	Off	Disables the Test Pattern feature.
		GreyHorizontalRamp	Sets to Grey Horizontal Ramp.
		GreyDiagonalRamp	Sets to Grey Diagonal Ramp.
		GreyDiagonalRampMoving	Sets to Grey Diagonal Ramp Moving.
		SensorSpecific	Sets to the Test Pattern generated by the image sensor.

Table 9-28 XML Parameter related to Test Pattern

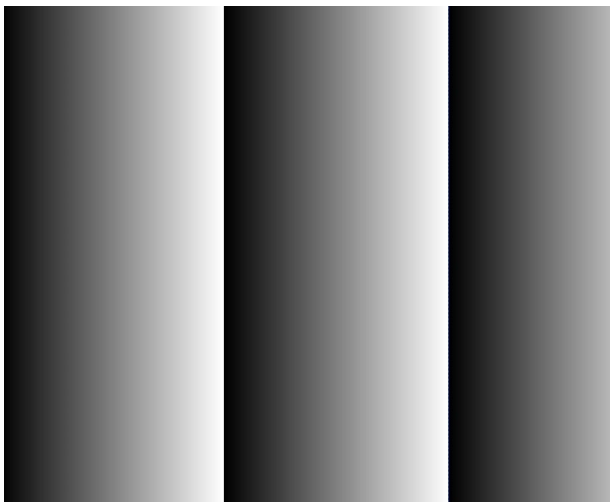

Figure 9-17 Grey Horizontal Ramp



Figure 9-18 Grey Diagonal Ramp



Figure 9-19 Grey Diagonal Ramp Moving

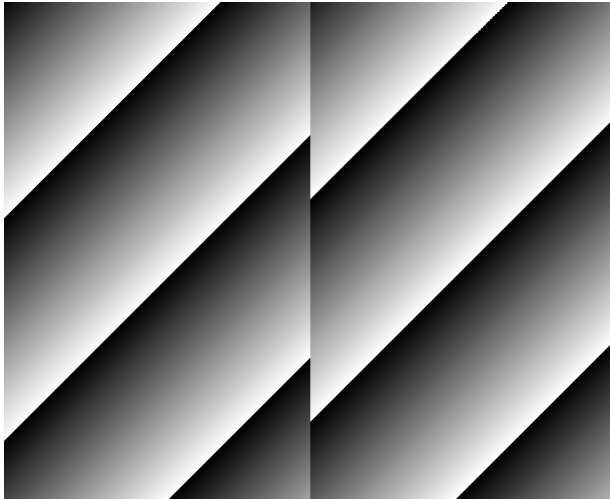

Figure 9-20 Sensor Specific



Caution!

The test pattern may look different because the region of the test pattern may vary depending on the camera's resolution.

9.24 Reverse X

The Reverse X feature lets you flip images horizontally. This feature is available in almost all of operation modes of the camera, except for the Test Image mode.

XML Parameter		Value	Description
ImageFormatControl	ReverseX	FALSE	Disables the Reverse X feature.
		TRUE	Flips images horizontally.

Table 9-29 XML Parameter related to Reverse X



Figure 9-21 Original Image



Figure 9-22 Reverse X Image

9.25 Reverse Y

The Reverse Y feature lets you flip images vertically. This feature is available in all operation modes of the camera. The XML parameter related to Reverse Y is as follows.

XML Parameters		Value	Description
ImageFormatControl	ReverseY	FALSE	Disables the Reverse Y feature.
		TRUE	Flips images vertically.

Table 9-30 XML Parameter related to Reverse Y



Figure 9-23 Original Image



Figure 9-24 Reverse Y Image



Note:

- When using the Reverse Y feature, it is recommended to regenerate the camera's correction data(DSNU, PRNU), and readjust the Black Level value(refer to 9.1).
- To apply the new color filter array to the color cameras in the series, it is recommended to execute the Reverse Y feature after choosing Bayer on the Pixel Format parameter.

9.26 Device Link Throughput Limit

The Device Link Throughput Limit feature allows you to limit the maximum available bandwidth for data transmission to your computer.

The XML parameter related to Device Link Throughput Limit is as follows.

XML Parameters		Description
DeviceControl	DeviceLinkThroughputLimit	Limits the maximum available bandwidth (bps).

Table 9-31 XML Parameter related to Device Link Throughput Limit



Caution!

To ensure good image quality, we recommend that you set the Device Link Throughput Limit parameter to the maximum value. Otherwise, the image quality can decrease. In case of the VP-103MX2-M/C24I, its maximum value is 8000.

9.27 Device User ID

You can input user-defined information up to 16 bytes.

The XML parameter related to Device User ID is as follows.

XML Parameter		Description
DeviceControl	DeviceUserID	Input user-defined information (16 bytes).

Table 9-32 XML Parameter related to Device User ID

9.28 Device Reset

Resets the camera physically to power off and on.

The XML parameter related to Device Reset is as follows.

XML Parameter		Description
DeviceControl	Device Reset	Resets the camera physically.

Table 9-33 XML Parameter related to Device Reset

9.29 Field Upgrade

The camera provides a feature to upgrade the Firmware and FPGA logic through the Camera Link interface without disassembling the camera in the field. Refer to **Appendix A** for more details about how to upgrade.

9.30 User Set Control

You can save the current camera settings to the camera's internal Flash memory. You can also load the camera settings from the camera's internal Flash memory. The camera provides two setups to save and three setups to load settings.

The XML parameters related to User Set Control are as follows.

XML Parameters	Value	Description	
UserSetControl	UserSetSelector	Default	Selects the Factory Default settings.
		UserSet1	Selects the UserSet1 settings.
		UserSet2	Selects the UserSet2 settings.
	UserSetLoad	-	Loads the User Set specified by User Set Selector to the camera.
	UserSetSave	-	Saves the current settings to the User Set specified by User Set Selector. The Default is a Factory Default Settings and allowed to load only.
	UserSetDefault	Default	Applies the Factory Default settings when reset.
		UserSet1	Applies the UserSet1 when reset.
		UserSet2	Applies the UserSet2 when reset.

Table 9-34 XML Parameters related to User Set Control

The camera settings stored in the Default can be loaded into the camera's workspace but cannot be changed. The settings set in the workspace will be lost if the camera is reset or powered off. To use the current setting values in the workspace after a reset, you must save the settings to one of the user spaces.

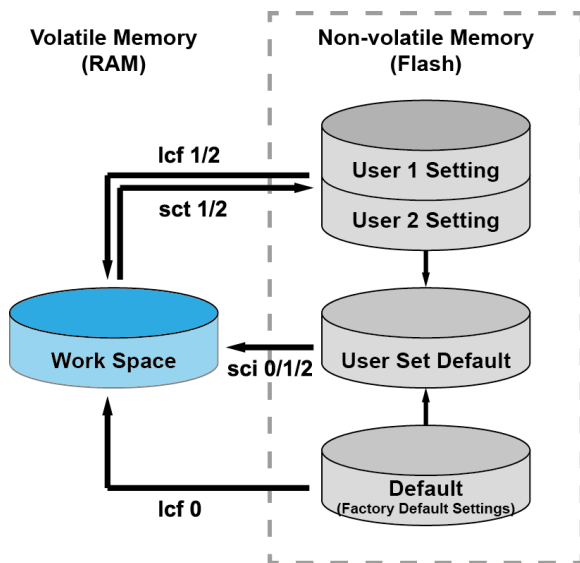

Figure 9-25 User Set Control

9.31 Sequencer Control

The Sequencer Control provided by the VP-103MX2-M/C24I cameras allows you to apply different sets of parameter settings, called 'Sequencer Set', to a sequence of image acquisitions. As the camera acquires images, it applies one Sequencer Set after the other. This allows the camera to respond quickly to changing imaging requirements. For example, changes in illumination conditions influence the imaging requirements.

With the User Set Control feature, you can save user defined Sequencer Sets in the camera's non-volatile memory. Then after the camera is powered on or reset, the Sequencer Sets are available according to the **User Set Default** parameter. Each Sequencer Set is identified by an index number ranging from 0 to 31. Accordingly, you can define up to 32 different Sequencer Sets. On the VP-103MX2-M/C24I cameras, only the Flat Field correction data can be configured for Sequencer Sets.

The XML parameters related to Sequencer Sets are as follows.

XML Parameters		Value	Description
Sequencer Control	SequencerMode	Off	Disables the Sequencer.
		On	Enables the Sequencer.
	Sequencer ConfigurationMode	Off	Disables the Sequencer Configuration Mode.
		On	Enables the Sequencer Configuration Mode.
	Sequencer FeatureSelector	FlatFieldData Selector GainDigitalAll ExposureTime	Selects a feature to be applied to Sequencer Sets.
	Sequencer FeatureEnable	Off	Disables the selected feature for the application of Sequencer Sets.
		On	Enables the selected feature for the application of Sequencer Sets.
	Sequencer SetSelector	0 – 31	Selects an index number of a Sequencer Set to be configured.
	SequencerSetActive	-	Displays the index number (0 - 31) of the Sequencer Set that is currently active.
	SequencerSetCount	1 – 32	Sets the number of Sequencer Sets to be applied.
SequencerReset	-	Returns to Sequencer Set 0.	

Table 9-35 XML Parameters related to Sequencer Control



Caution!

To apply Sequencer Sets, you must set the Trigger Mode parameter to On.

Use Case – Applying Four Different Sets of Flat Field Correction Data, Gain and Exposure Time Settings to Sequencer Sets

For example, assume that four different sets of Flat Field correction data, Gain and Exposure settings optimized for White, Green, Red and Blue pixels are applied to four different Sequencer Sets to inspect LCD panels.

1. Set the **Sequencer Mode** parameter to **Off**.
2. Select a feature to be applied to Sequencer Sets by using the **Sequencer Feature Selector** parameter.

You must select features to be applied to Sequencer Sets prior to entering the **Sequencer Configuration Mode**.

Set the **Sequencer Feature Selector** parameter to **Flat Field Data Selector**, and then set the **Sequencer Feature Enable** parameter to **On**.

Set the **Sequencer Feature Selector** parameter to **Gain Digital All**, and then set the **Sequencer Feature Enable** parameter to **On**.

Set the **Sequencer Feature Selector** parameter to **Exposure Time**, and then set the **Sequencer Feature Enable** parameter to **On**.

3. Set the **Sequencer Configuration Mode** parameter to **On**.
4. Set the **Sequencer Set 0** first.

Set the **Sequencer Set Selector** parameter to **0**, and then set the **Flat Field Data Selector** parameter to **Space0** in the **Flat Field Control** category. Then, set the **Gain** parameter to **1** in the **Analog Control** category, and then set the **Exposure Time** parameter to **10000** in the **Acquisition Control** category.

5. By following the procedure in the step 4, set the **Sequencer Set 1**, **Sequencer Set 2** and **Sequencer Set 3** as shown below.

Sequencer Set 1 → Flat Field Data Selector = Space 1, Gain = 2, Exposure Time = 20000

Sequencer Set 2 → Flat Field Data Selector = Space 2, Gain = 3, Exposure Time = 30000

Sequencer Set 3 → Flat Field Data Selector = Space 3, Gain = 4, Exposure Time = 40000

6. Set the **Sequencer Set Count** parameter to **4**.
7. Set the **Sequencer Configuration Mode** parameter to **Off**, and then set the **Sequencer Mode** parameter to **On**.

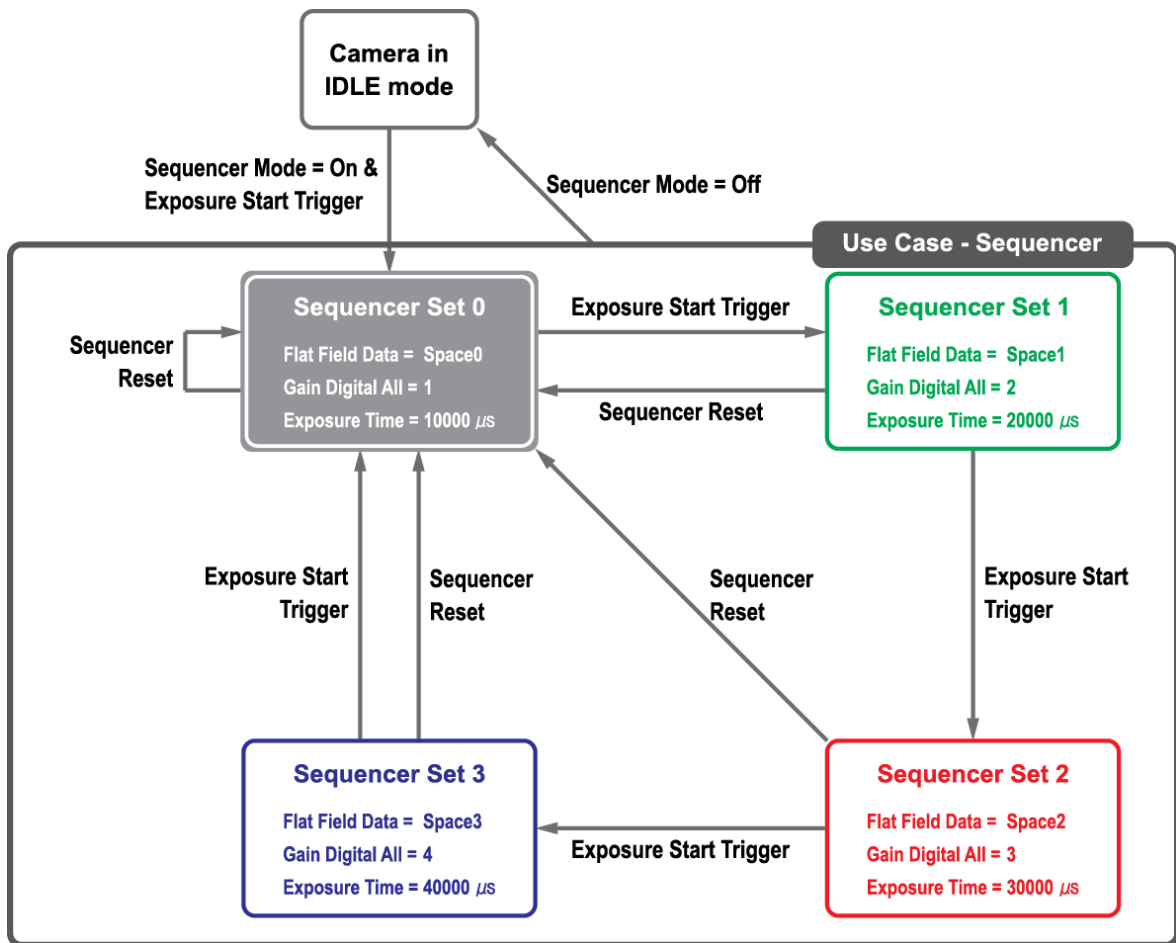

Figure 9-26 Sequencer Diagram (Use Case)



Note:

- When you set the Sequencer Configuration Mode parameter to On, the following features will be enabled for the application of Sequencer Sets by default.
Flat Field Data Selector = Enabled, Space0
Gain Digital All = Enabled, Gain = 1
Exposure Time = Enabled, 10000
- You can save the user defined Sequencer Sets in the camera's non-volatile memory by using the User Set Control feature. For more information, refer to 9.30 User Set Control.
- Executing the Sequencer Reset parameter allows to return to the Sequencer Set 0 status at any time while cycling through the Sequencer.

Chapter 10. Troubleshooting

When you have a problem with a Vieworks camera, please check the followings:

- If no image is displayed on your computer,
 - Ensure that all cable connections are secure.
 - Ensure that the power supply is properly connected.
 - Ensure that trigger signals are applied correctly when you operate the camera with trigger signals.
- If images are not clear,
 - Ensure the camera lens or glass is clean.
 - Check the lens aperture is adjusted properly.
- If images are dark,
 - Ensure the camera lens is not blocked.
 - Check the exposure time is set properly.
- If you identify abnormal operation or overheating sign,
 - Ensure the power supply is properly connected.
 - Stop using the camera when you notice smoke or abnormal overheating.
- If you have a problem using the Trigger Mode,
 - Ensure that the Software trigger related parameters are configured correctly.
 - Ensure that the trigger related parameters on your CXP-12 Frame Grabber are configured correctly when you set the Trigger Source parameter to LinkTrigger0.
 - Ensure that cable connections are secure when you set the Trigger Source parameter to Line 0.
- If there is communication failure between the camera and computer,
 - Ensure coax cables are connected properly.
 - Ensure that you have configured a CXP-12 Frame Grabber in your computer correctly and the camera is connected properly to the CXP-12 Frame Grabber.

Appendix A. Defective Pixel Map Download

1. Create the Defective Pixel Map data in Microsoft Excel format as shown in the left picture below and save as a CSV file (*.csv). The picture in the right shows the created Excel file opened in Notepad. The following rules need to be applied when creating the file.

- Lines beginning with ':' or '--' are treated as notes.
- You must enter the horizontal value first and then the vertical value for coordinates of each defect pixel.
- Coordinate values for each pixel can be placed in any order.

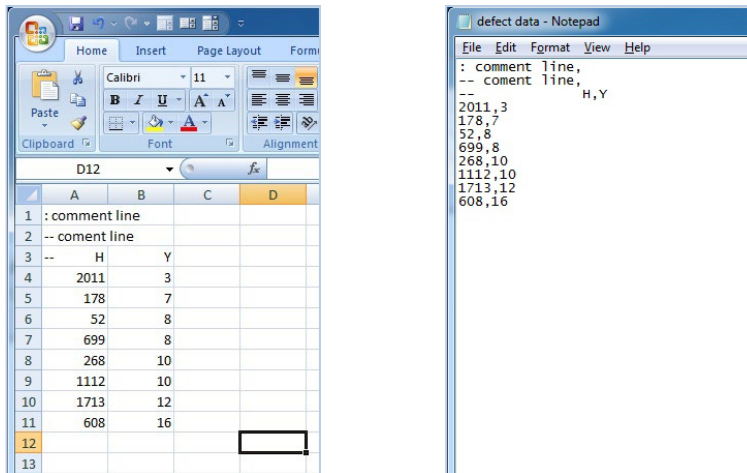

2. Run Vieworks Imaging Solution 7.X and click the **Configure** button to display the window as shown below. Select the **Defect** tab, click the **File Path** item, search and select the defective pixel map (*.csv), and then click the **Download** button.

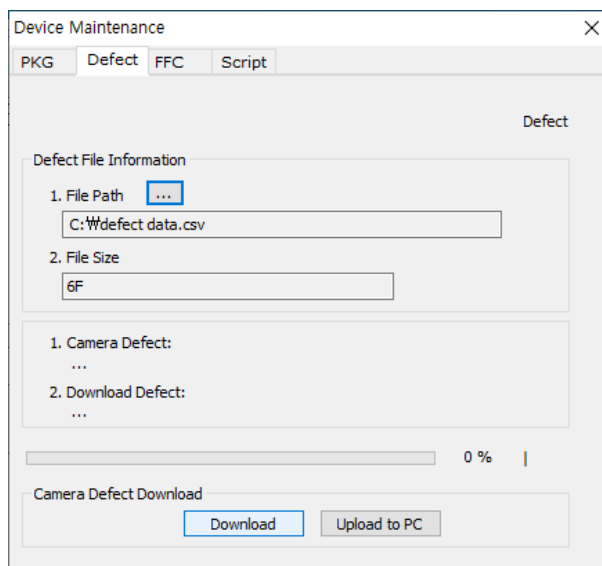

Appendix B. Field Upgrade

You can upgrade the MCU, FPGA and XML file of the camera by following the procedure below.

1. Run Vieworks Imaging Solution 7.X and click the **Configure** button to display the window as shown below.
2. Select the **PKG** tab, click the button next to **File Path**, search and select the MCU, FPGA or XML upgrade file, and then click the **Download** button.

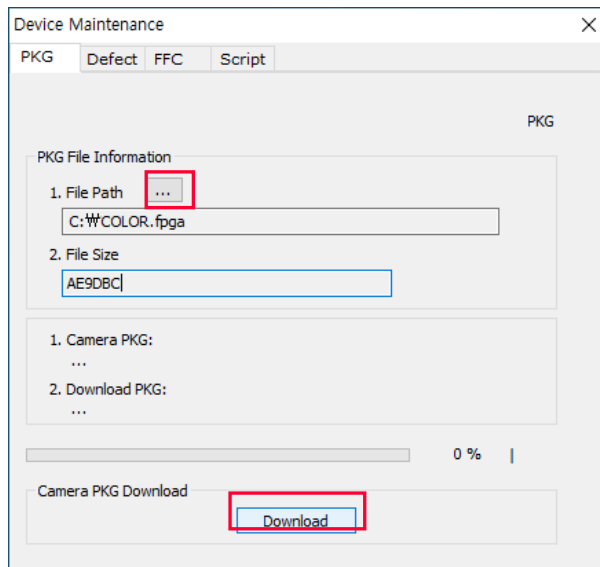

3. The camera begins downloading the upgrade file and the downloading status is displayed at the bottom of the window.

Appendix C. Index

4

4-pin connector.....30

6

6-pin connector.....29

A

acquisition control.....32

Acquisition Mode

 Continuous parameter.....33

 MultiFrame parameter33

 SingleFrame parameter33

Acquisition Mode parameter33

acquisition process.....47

Acquisition Start command.....33

Acquisition Stop command.....33

adjusting Black Level.....66

any edge.....38

B

back panel.....27

Bayer GB 8/10/12.....63

Black Level correction.....66

Black-Level adjustment.....66

Black-level signal68

block diagram.....22

C

camera ON&OFF92

camera's pixel formats.....63

camera's temperature, parameters86

circuit31

Continuous parameter.....33

correction data into a sequencer set97

correction of Black Level.....66

CXP connector27, 28

D

defect pixel	70
diagram	22
dimension	24
downloading Vieworks Imaging Solution.....	26
downloading VIS	26
DSNU data, generation.....	71

E

Exposure Mode	
Timed	36
TriggerWidth	36
Exposure Mode parameter	36

F

falling edge	38
Flat Field Correction data, generation	75
Flat Filed data into a sequencer	97
frame acquisition process	47
Free-run.....	37

G

gain value, setting	66
generating data of Flat Field correction.....	75

H

hardware trigger signal.....	42
Hirose	29, 30
Hirose 4-pin connector	30
Hirose 6-pin connector	29

I

image-correction sequence	68
inputting information of user's choice	92

K

key features.....	20
-------------------	----

L

LED status	86
level high	38
level low	38
Line0	35
LinkTrigger0.....	35
LinkTrigger0-Trigger	41

M

main features	20
Mating	29
mechanical dimension	24
Mono 8/10/12	63
MultiFrame parameter	33
Multi-ROI, determination	59

O

offset to pixel	66
offset value, setting	66
Optical Black Correction	66
order of image correction	68
order of signal processing	68
order of signals	52
overlapped exposure	47

P

pixel formats	63
preface	3, 7
PRNU	73

Q

QE	23
quantum efficiency	23

R

reset physically	92
rising edge	38
ROI-origin position	54
ROI-size setting	54

S

schematic diagram	31
sequence of image correction	68
sequence of signal processing	68
sequence of signals	52
signal processing	52
signal-processing sequence	68
signals' order	52
signals' sequence	52
SingleFrame parameter	33
Software	35
specification	21
spectral sensitivity	23
strobe output	31

T

Target Level AUTO74

tilt settings26

Timed36

Timer0Active35

trigger hardware42

trigger input31

Trigger Signals.....35

Trigger Source

 Line035

 LinkTrigger0.....35

 Software35

 Timer0Active.....35

 UserOutput0.....35

Trigger Source parameter35

TriggerWidth36

TriggerWidth mode.....45

U

UserOutput035

V

Vieworks Imaging Solution.....7

Vieworks Imaging Solution download.....26

VIS.....7, 26

VIS installation.....26

VP-103MX2-M/C24I specification21

X

XML parameter

 Analog Control.....66, 69

 AnalogControl.....65

 AnyEdge.....84

 Average.....60

 BalanceRatio65

 BalanceRatioSelector65

 BalanceWhiteAuto65

 BinningHorizontal.....60

 BinningHorizontalMode60

 BinningSelector60

 BinningVertical.....60

 BinningVerticalMode

 Average60

 Sum.....60

 BlackLevel69

 BlackLevelOffset69

 BlackLevelSelector69

 CC184

 CoaXPRESS62

 CounterAndTimeControl.....84

 CxpLinkConfiguration.....62

 CxpLinkConfigurationPreferred62

 DataRoiControl64

 Debounce Time83

 DebounceTime81

 Device Reset92

 DeviceControl.....86, 92

 DeviceLinkThroughputLimit92

 DeviceTemperature86

 DeviceTemperatureSelector86

 DeviceUserID92

 DigitalIOControl81, 83

 DSNUGenerate.....71

 DSNULoad71

 DSNUSave71

 EventNotification80

 EventSelector80

 ExposureActive.....81, 84

 FallingEdge.....84

 FanOperationMode85

 FanSpeed.....85

 Flat Field Data Selector78

 FlatFieldControl.....77

 FlatFieldCorrection77

 FlatFieldDataGenerate.....77

 FlatFieldDataLoad77

 FlatFieldDataSave77

 FlatFieldDataSelector77

 FlatFieldTargetLevel.....77

 FlatFieldTargetSelector77

 FrameActive81, 84

 Gain66

 GainSelector.....66

GreyDiagonalRamp	87	RoiSelector	64
GreyDiagonalRampMoving	87	RoiWidth	64
GreyHorizontalRamp	87	SensorHeight	54
Height	54	SensorSpecific	87
HeightMax	54	SensorWidth	54
ImageFormatControl	54, 60, 63, 69, 90, 91	SequencerConfigurationMode	95
Input	81	SequencerControl	95
LevelHigh	84	SequencerFeatureEnable	95
LevelLow	84	SequencerFeatureSelector	95
Line 0	81	SequencerMode	95
Line 1	81	SequencerSetActive	95
Line0	84	SequencerSetCount	95
LineInverter	81	SequencerSetSelector	95
LineMode	81	Sum	60
LineSelector	81	TargetLevelAUTO	73
LineSource	81	TargetTemperature	85
MultiROIControl	57	TestPattern	87
MultiROIHeight	57	Timer0Active	81
MultiROIMode	57	TimerDelay	84
MultiROIOffsetX	57	TimerDuration	84
MultiROIOffsetY	57	TimerReset	84
MultiROISelector	57	TimerTriggerActivation	84
MultiROIStatus	57	TimerTriggerSource	84
MultiROIValid	57	Timestamp	79
MultiROIWidth	57	TimestampIncrement	79
OffsetX	54	TimestampLatch	79
OffsetY	54	TimestampLatchValue	79
OpticalBlackCorrection	69	TimestampReset	79
Output	81	TimestampResetValue	79
PixelFormat	63	UserDefault	93
PRNU Generate	73	UserOutput0	81
PRNU Selector	73	UserOutputValue	81
PRNU Load	73	UserSet1	93
PRNU Mode	73	UserSet2	93
PRNU Save	73	UserSetControl	93
PRNU TargetLevel	73	UserSetLoad	93
ReverseX	90	UserSetSave	93
ReverseY	91	UserSetSelector	93
RisingEdge	84	White Balance Auto	64
RoiHeight	64	Width	54
RoiOffsetX	64	WidthMax	54
RoiOffsetY	64		

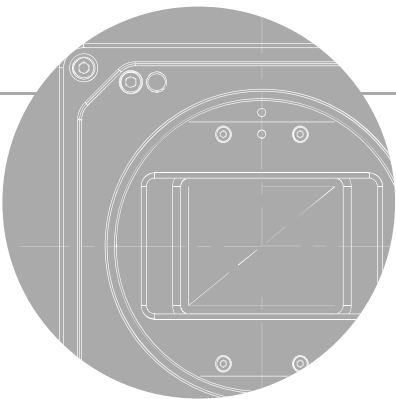
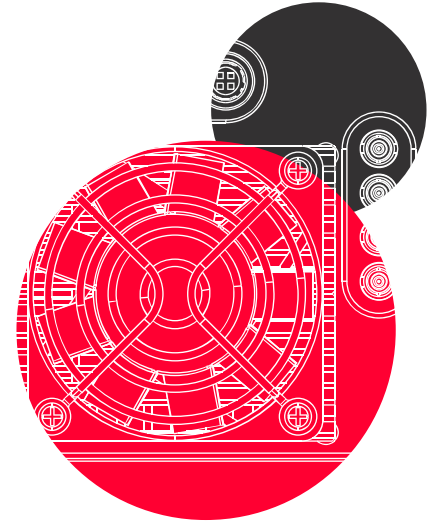
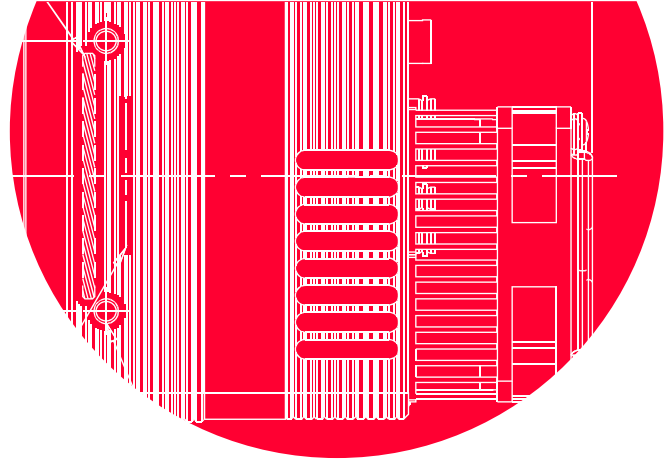

Vieworks Co., Ltd.

41-3, Burim-ro, 170beon-gil,
Dongan-gu, Anyang-si, Gyeonggi-do
14055 Republic of Korea

Tel: +82-70-7011-6161

Fax: +82-31-386-8631

<http://vision.vieworks.com>

vision@vieworks.com